

RAD-SOL-SET-24-100-US - Solar system



5605943

<https://www.phoenixcontact.com/us/products/5605943>

Please be informed that the data shown in this PDF document is generated from our online catalog. Please find the complete data in the user documentation. Our general terms of use for downloads are valid.



Complete solar system, consisting of solar panel and control cabinet with charge controller, solar battery, surge protection, fuses and mounting material.

Your advantages

- Prewired control cabinet including charge controller, solar battery, surge protection, and fuses
- Optional wall or mast mounting

Commercial data

Item number	5605943
Packing unit	1 pc
Note	Made to order (non-returnable)
Sales key	DN23
Product key	DNC6P1
GTIN	4046356150279
Weight per piece (including packing)	450 g
Weight per piece (excluding packing)	450 g
Customs tariff number	85013100
Country of origin	DE

RAD-SOL-SET-24-100-US - Solar system



5605943

<https://www.phoenixcontact.com/us/products/5605943>

Set consists of

RAD-SOL-CHG-24- 10 - Charge controller

2885443

<https://www.phoenixcontact.com/us/products/2885443>

Fully automatic charge controller with electronic protection functions, for photovoltaic systems with a system voltage of 24 V.



5605943

<https://www.phoenixcontact.com/us/products/5605943>

Technical data

Electrical properties

Operating voltage	24 V DC
-------------------	---------

Dimensions

Width	489 mm
Height	822.4 mm
Depth	337.7 mm

Environmental and real-life conditions

Ambient conditions

Ambient temperature (operation)	-30 °C ... 60 °C
Ambient temperature (storage/transport)	-30 °C ... 60 °C
Wind velocity	25 m/s (per m ² corresponds to wind load zone 2, at a force of 0.39 kN)

RAD-SOL-SET-24-100-US - Solar system

5605943

<https://www.phoenixcontact.com/us/products/5605943>

Drawings

Schematic diagram

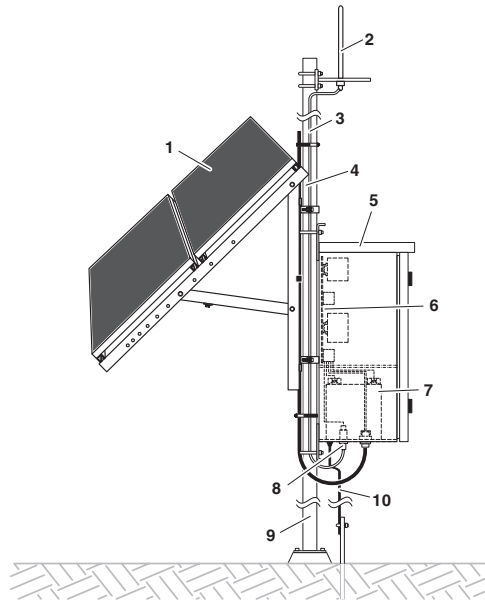

- 1 2 solar panels (conn. in series)
- 2 Antenna
- 3 Antenna cable
- 4 Flexible protective tubing
- 5 Control cabinet
- 6 Control cabinet electronics
- 7 Batteries
- 8 Surge protection for antenna cable and control cabinet electronics
- 9 Mast (e.g. signpost with 76 mm diameter)
- 10 Protective earth (PE), grounding cable

Example for a typical assembly of a solar system

RAD-SOL-SET-24-100-US - Solar system



5605943

<https://www.phoenixcontact.com/us/products/5605943>

Environmental product compliance

EU REACH SVHC

REACH candidate substance (CAS No.)	No substance above 0.1 wt%
-------------------------------------	----------------------------

Phoenix Contact 2026 © - all rights reserved

<https://www.phoenixcontact.com>

Phoenix Contact USA
586 Fulling Mill Road
Middletown, PA 17057, United States
(+717) 944-1300
info@phoenixcon.com