

RSCWE 6-3/15 - Test terminal strip



3969954

<https://www.phoenixcontact.com/us/products/3969954>

Please be informed that the data shown in this PDF document is generated from our online catalog. Please find the complete data in the user documentation. Our general terms of use for downloads are valid.



Test terminal strip, nom. voltage: 400 V, number of connections: 30, number of positions: 15, connection method: Ring cable lug, Rated cross section: 6 mm², 1 level, mounting type: Panel mounting, color: gray

The figure shows a version of the article

Your advantages

- Space saving, thanks to compact, modular test terminal strips
- Cost-effective, thanks to the tailored, modular design and use of standardized CLIPLINE complete accessories
- Maximum safety with leading and automatic transformer short circuit
- The integrated, robust switch contact is designed for the most stringent demands, and the use of high-quality materials ensures the transmission of signal currents, even after multiple actuations

Commercial data

Item number	3969954
Packing unit	1 pc
Minimum order quantity	1 pc
Sales key	BE06
Product key	BE6113
GTIN	4055626394657
Weight per piece (including packing)	592 g
Weight per piece (excluding packing)	573.61 g
Customs tariff number	85369010
Country of origin	PL

3969954

<https://www.phoenixcontact.com/us/products/3969954>

Technical data

Product properties

Product type	Test terminal strip
Product family	FAME 3
Number of positions	15
Pitch	8.2 mm
Number of connections	30
Number of rows	1
Potentials	15

Insulation characteristics

Overvoltage category	III
----------------------	-----

Electrical properties

Rated surge voltage	4 kV
Maximum power dissipation for nominal condition	1.31 W
Test surge voltage	5 kV

Connection data

Number of connections per level	30
Nominal cross section	6 mm ²

1 level

Connection method	Ring cable lug
Screw thread	No 8 UNC
Tightening torque	1.5 ... 1.8 Nm
Internal cylindrical gage	A5
Connection in acc. with standard	IEC 60947-7-1
Conductor cross-section flexible	0.5 mm ² ... 10 mm ²
Conductor cross-section, flexible [AWG]	24 ... 8 (converted acc. to IEC)
2 conductors with same cross section, rigid	0.5 mm ² ... 6 mm ²
2 conductors with same cross section, flexible	0.5 mm ² ... 6 mm ²
Nominal cross section	6 mm ²
Maximum load current	30 A (with 10 mm ² conductor cross-section)
Nominal voltage	400 V AC/DC

Cable lug connection DIN 46234:1980-03

Connection in acc. with standard	DIN 46234:1980-03
Cross section	0.5 mm ² ... 10 mm ²
Cross section range AWG	(converted acc. to IEC)
Hole diameter	4.3 mm
Width	8 mm
Bolt diameter	4.1 mm
Connection in acc. with standard	DIN 46237:1970-07

RSCWE 6-3/15 - Test terminal strip

3969954

<https://www.phoenixcontact.com/us/products/3969954>

Cross section	0.5 mm ² ... 10 mm ²
Cross section range AWG	(converted acc. to IEC)
Hole diameter	4.3 mm
Width	8 mm
Bolt diameter	4.1 mm
Identification color of ring cable lugs : red	1 mm ²
Identification color of ring cable lugs : blue	2.5 mm ²
Identification color of ring cable lugs : yellow	6 mm ²

Dimensions

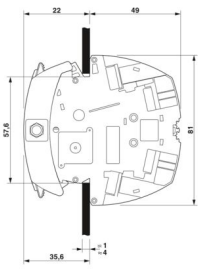
Dimensional drawing	
Width	154.9 mm
Height	81 mm
Depth	70.1 mm
Pitch	8.2 mm
Plate thickness	1 mm ... 4 mm

Material specifications

Color	gray (RAL 7042)
Flammability rating according to UL 94	V0
Insulating material group	I
Insulating material	PA

Mechanical properties

General

Terminal block mounting	0.8 Nm ... 1 Nm
-------------------------	-----------------

Mechanical data

Open side panel	No
-----------------	----

Environmental and real-life conditions

Ambient conditions

Ambient temperature (storage/transport)	-25 °C ... 60 °C (for a short time, not exceeding 24 h, -60 °C to +70 °C)
Ambient temperature (assembly)	-5 °C ... 70 °C
Ambient temperature (actuation)	-5 °C ... 70 °C
Permissible humidity (storage/transport)	30 % ... 70 %

RSCWE 6-3/15 - Test terminal strip



3969954

<https://www.phoenixcontact.com/us/products/3969954>

Standards and regulations

Connection in acc. with standard	IEC 60947-7-1
----------------------------------	---------------

Mounting

Mounting type	Panel mounting
Terminal block mounting	0.8 Nm ... 1 Nm

RSCWE 6-3/15 - Test terminal strip

3969954

<https://www.phoenixcontact.com/us/products/3969954>

Drawings

Dimensional drawing

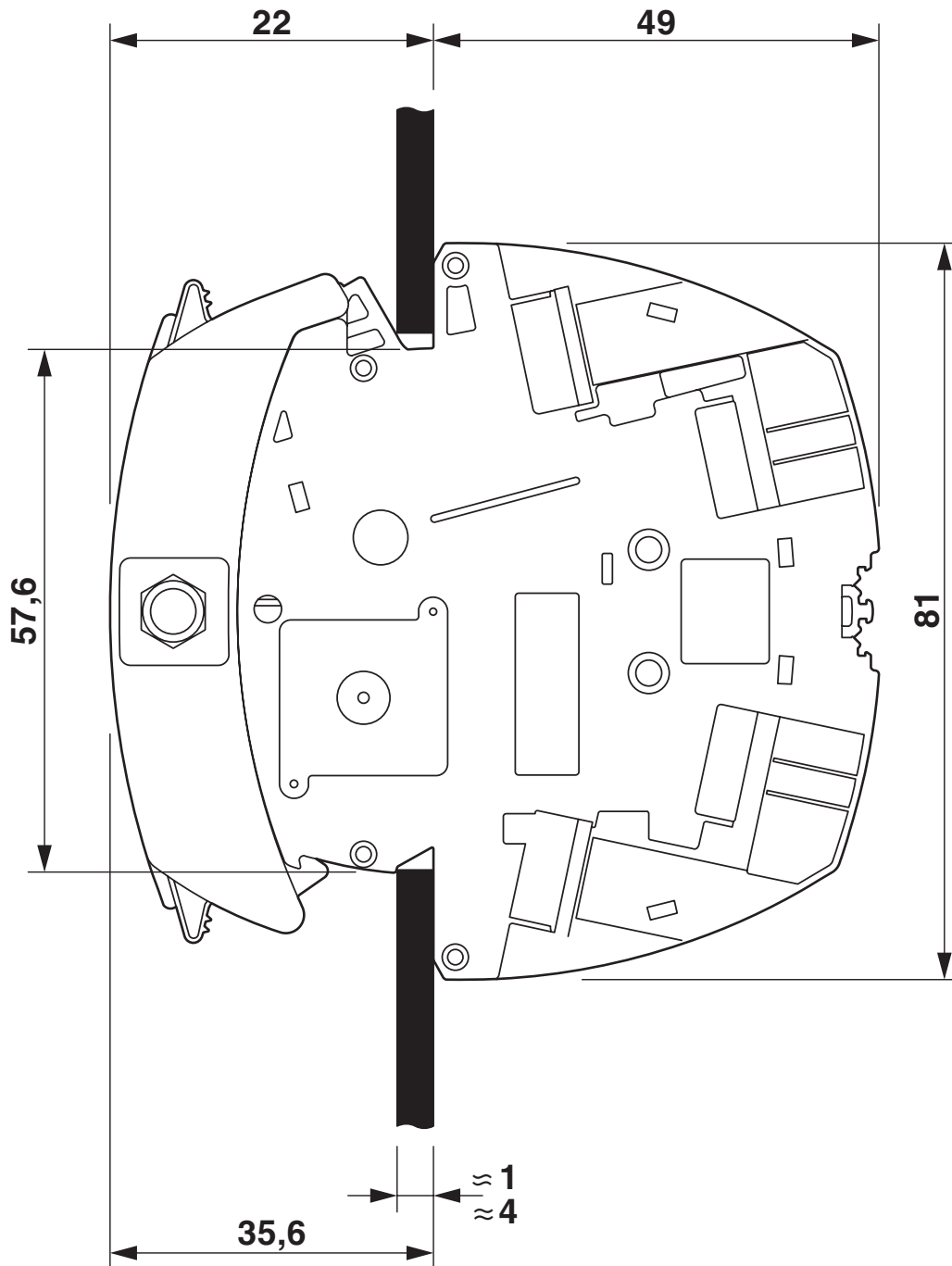

RSCWE 6-3/15 - Test terminal strip



3969954

<https://www.phoenixcontact.com/us/products/3969954>

Dimensional drawing

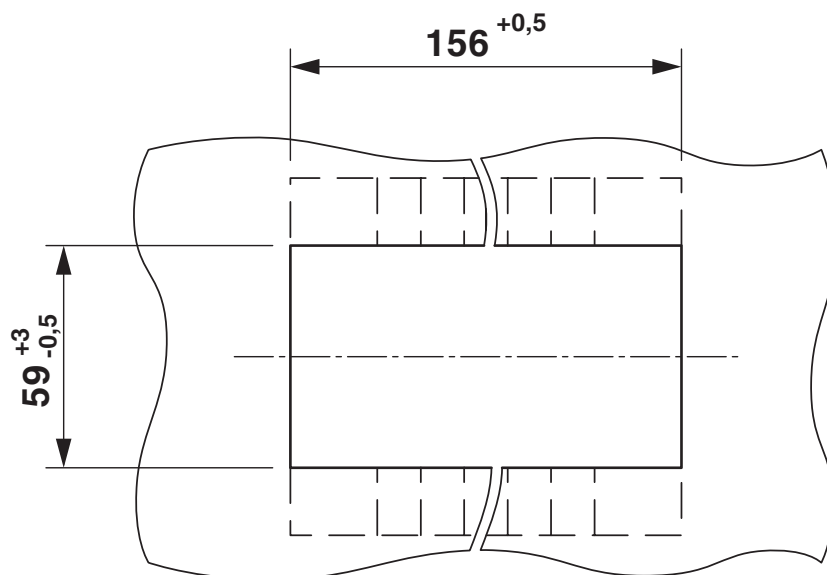

RSCWE 6-3/15 - Test terminal strip

3969954

<https://www.phoenixcontact.com/us/products/3969954>



Circuit diagram

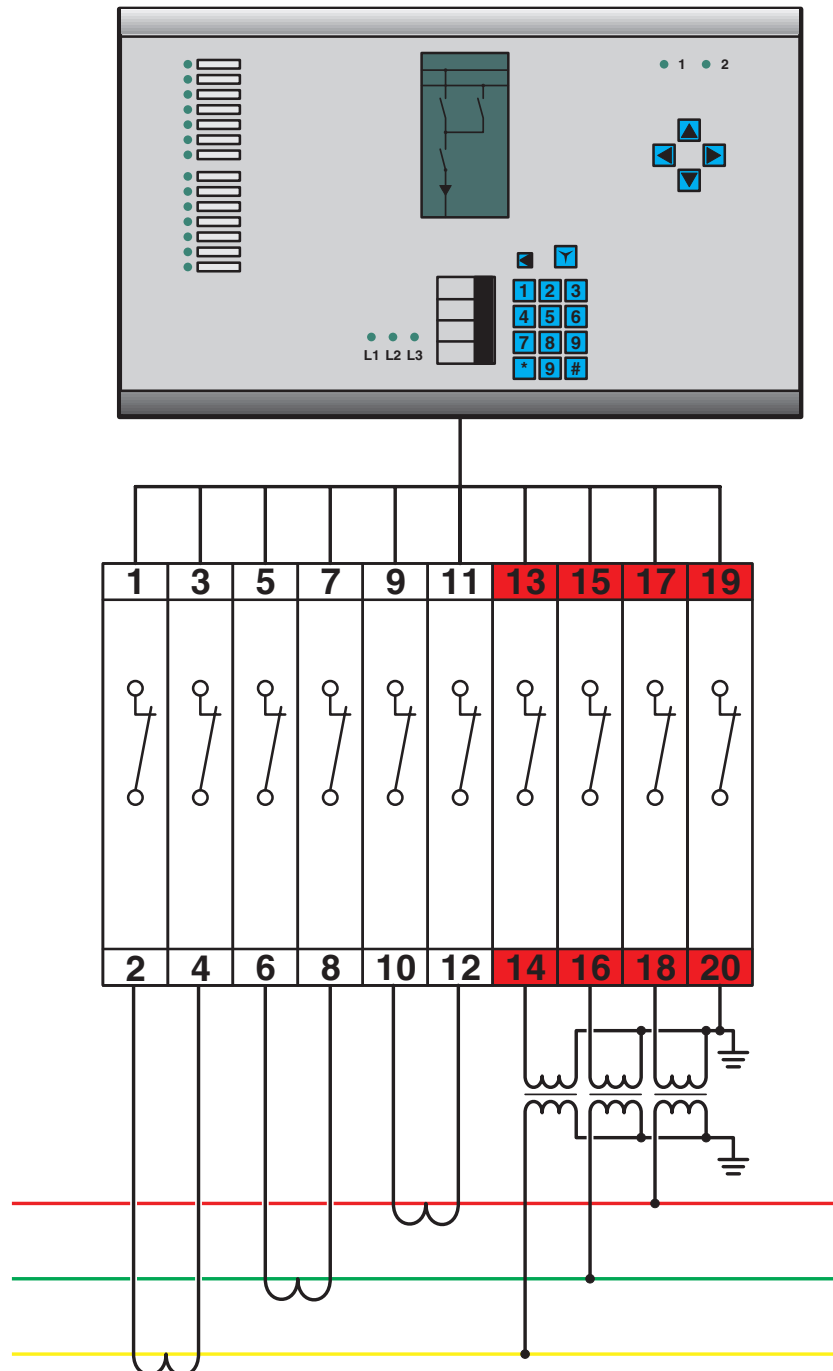

RSCWE 6-3/15 - Test terminal strip





3969954

<https://www.phoenixcontact.com/us/products/3969954>

Approvals

To download certificates, visit the product detail page: <https://www.phoenixcontact.com/us/products/3969954>

 cULus Recognized Approval ID: E60425				
	Nominal voltage U_N	Nominal current I_N	Cross section AWG	Cross section mm^2
B	600 V	31 A	20 - 8	-
C	600 V	31 A	20 - 8	-
D	600 V	5 A	20 - 8	-

 EAC Approval ID: RU C-DE.BL08.B.00682				
---	--	--	--	--

 CSA Approval ID: 13631				
	Nominal voltage U_N	Nominal current I_N	Cross section AWG	Cross section mm^2
B	600 V	31 A	20 - 8	-
C	600 V	31 A	20 - 8	-

RSCWE 6-3/15 - Test terminal strip



3969954

<https://www.phoenixcontact.com/us/products/3969954>

Classifications

ECLASS

ECLASS-13.0	27250190
ECLASS-15.0	27250190

ETIM

ETIM 10.0	EC002848
-----------	----------

UNSPSC

UNSPSC 21.0	39121400
-------------	----------

RSCWE 6-3/15 - Test terminal strip



3969954

<https://www.phoenixcontact.com/us/products/3969954>

Environmental product compliance

EU RoHS

Fulfills EU RoHS substance requirements	Yes, No exemptions
---	--------------------

China RoHS

Environment friendly use period (EFUP)	EFUP-E
	No hazardous substances above the limits

EU REACH SVHC

REACH candidate substance (CAS No.)	No substance above 0.1 wt%
-------------------------------------	----------------------------

Phoenix Contact 2026 © - all rights reserved
<https://www.phoenixcontact.com>

Phoenix Contact USA
586 Fulling Mill Road
Middletown, PA 17057, United States
(+717) 944-1300
info@phoenixcon.com