

C-RCEI 1,5/M3 - Ring cable lug

3241201

<https://www.phoenixcontact.com/us/products/3241201>

Please be informed that the data shown in this PDF document is generated from our online catalog. Please find the complete data in the user documentation. Our general terms of use for downloads are valid.



Ring cable lug, red, 0.5 ... 1.5 mm², M3, with copper sleeve incorporated, for insulation crimp

Your advantages

- The sleeves are conically tapered to facilitate easy and correct insertion of the conductor
- The mechanical load capacity of the connection is significantly increased by the additionally applied copper sleeve (insulation crimp)

Commercial data

Item number	3241201
Packing unit	100 pc
Minimum order quantity	100 pc
Sales key	BH34
Product key	BH3421
GTIN	4046356816168
Weight per piece (including packing)	0.785 g
Weight per piece (excluding packing)	0.785 g
Customs tariff number	85369010
Country of origin	TW

C-RCEI 1,5/M3 - Ring cable lug

3241201

<https://www.phoenixcontact.com/us/products/3241201>

Technical data

Product properties

Product type	Connector
Product property	Halogen-free
	Conical conductor entry
	Brazed
	PA-insulated
	With copper sleeve incorporated, for insulation crimp
	Tin-plated
	Temperature range: -20°C ... +105°C
Flammability rating V2 in accordance with UL 94	

Dimensions

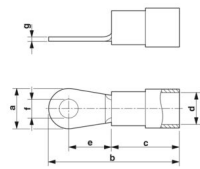
Dimensional drawing	
Width	5.5 mm
Sleeve length	17.7 mm
Length of the insulating material sleeve	11 mm
Distance from the center to the insulating material sleeve	4 mm
Min. material thickness	0.75 mm
Inner dimensions of the insulating collar	4.1 mm

Internal dimensions

Internal diameter	3.2 mm
-------------------	--------

Material specifications

Color	red (RAL 3001)
Material	Copper
Flammability rating according to UL 94	V2
Coating	tin-plated
Insulating material	PA
Components	halogen-free

Mechanical properties

Technical data

Sleeve length	17.7 mm
---------------	---------

Environmental and real-life conditions

C-RCEI 1,5/M3 - Ring cable lug



3241201

<https://www.phoenixcontact.com/us/products/3241201>

Ambient conditions

Optimum ambient temperature (storage/transport)	20.00 °C 50.00 % Humidity (RH), store inside sealed original packaging. Avoid direct sunlight and heat.
Ambient temperature (operation)	-20 °C ... 105 °C
Ambient temperature (assembly)	-20 °C ... 100 °C
Short-term temperature	100 °C

C-RCEI 1,5/M3 - Ring cable lug

3241201

<https://www.phoenixcontact.com/us/products/3241201>



Drawings

Dimensional drawing



C-RCEI 1,5/M3 - Ring cable lug



3241201

<https://www.phoenixcontact.com/us/products/3241201>

Classifications

ECLASS

ECLASS-13.0	27400204
ECLASS-15.0	27400204

ETIM

ETIM 10.0	EC001052
-----------	----------

UNSPSC

UNSPSC 21.0	27121700
-------------	----------

C-RCEI 1,5/M3 - Ring cable lug



3241201

<https://www.phoenixcontact.com/us/products/3241201>

Environmental product compliance

EU RoHS

Fulfills EU RoHS substance requirements	Yes, No exemptions
-----------------------------------------	--------------------

China RoHS

Environment friendly use period (EFUP)	EFUP-E
	No hazardous substances above the limits

EU REACH SVHC

REACH candidate substance (CAS No.)	No substance above 0.1 wt%
-------------------------------------	----------------------------

EF3.1 Climate Change

CO2e kg	0.02 kg CO2e
---------	--------------

Phoenix Contact 2026 © - all rights reserved
<https://www.phoenixcontact.com>

Phoenix Contact USA
586 Fulling Mill Road
Middletown, PA 17057, United States
(+717) 944-1300
info@phoenixcon.com