

STG-MTN 1,5-2,5 - Crimp contact



3190506

<https://www.phoenixcontact.com/us/products/3190506>

Please be informed that the data shown in this PDF document is generated from our online catalog. Please find the complete data in the user documentation. Our general terms of use for downloads are valid.



Module socket contact, inserted in the PCC or HCC plug housing after crimping the conductor, for 1.5 mm² ... 2.5 mm² conductors

Commercial data

Item number	3190506
Packing unit	100 pc
Minimum order quantity	100 pc
Sales key	AA03
Product key	AACCEG
GTIN	4017918093372
Weight per piece (including packing)	0.471 g
Weight per piece (excluding packing)	0.462 g
Customs tariff number	85366990
Country of origin	CN

STG-MTN 1,5-2,5 - Crimp contact

3190506

<https://www.phoenixcontact.com/us/products/3190506>



Drawings

Dimensional drawing

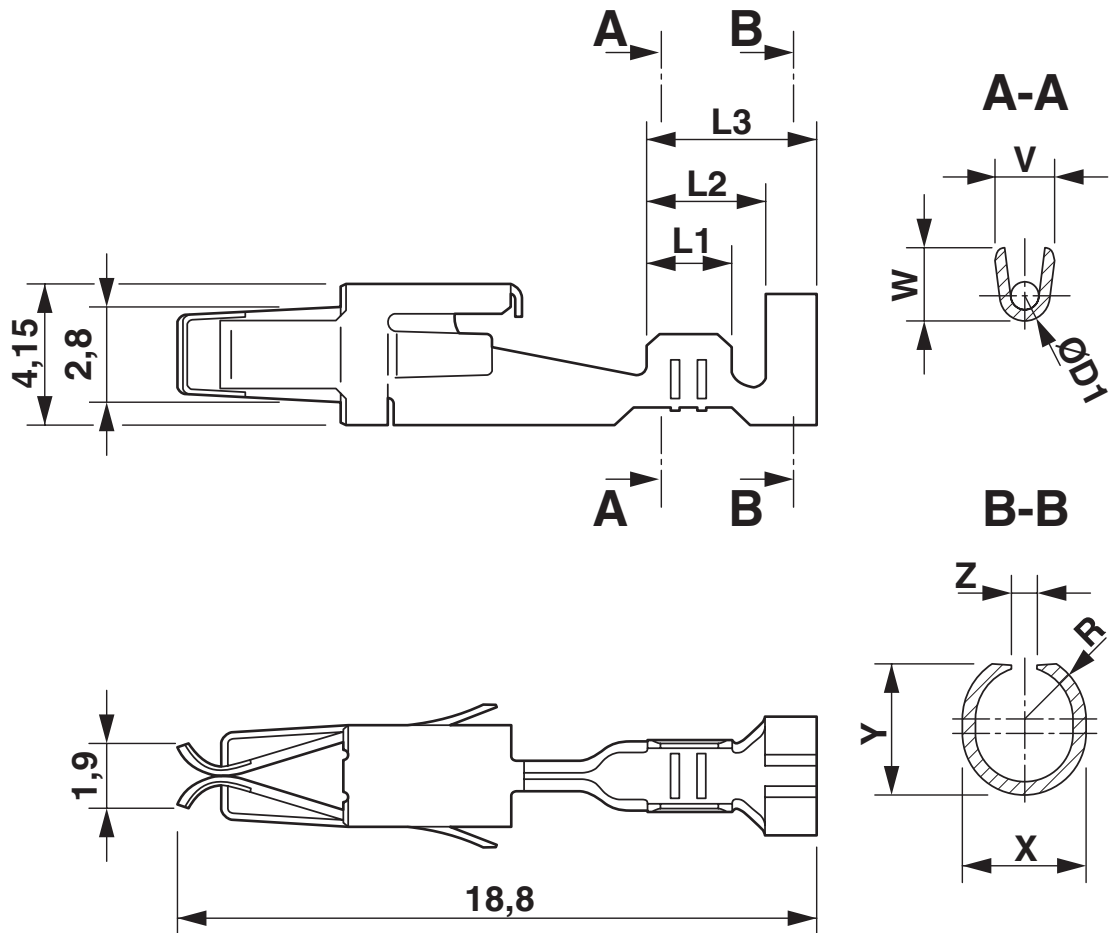

STG-MTN 1,5-2,5 - Crimp contact



3190506

<https://www.phoenixcontact.com/us/products/3190506>

Diagram

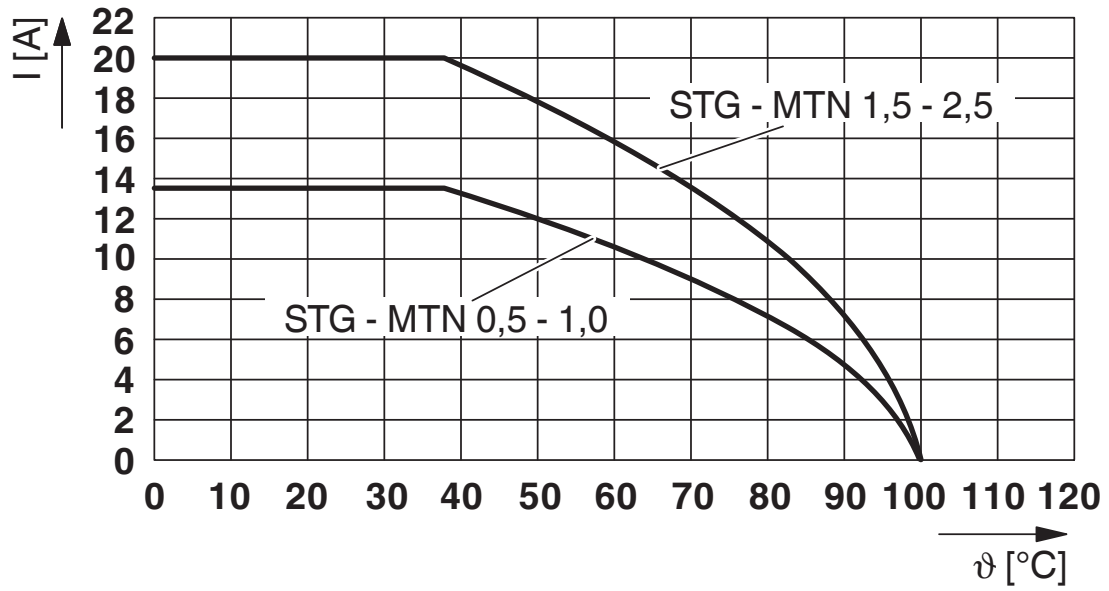

STG-MTN 1,5-2,5 - Crimp contact



3190506

<https://www.phoenixcontact.com/us/products/3190506>

Classifications

ECLASS

ECLASS-13.0	27469090
ECLASS-15.0	27469090

ETIM

ETIM 10.0	EC002943
-----------	----------

UNSPSC

UNSPSC 21.0	39121400
-------------	----------

STG-MTN 1,5-2,5 - Crimp contact



3190506

<https://www.phoenixcontact.com/us/products/3190506>

Environmental product compliance

China RoHS

Environment friendly use period (EFUP)	EFUP-E
	No hazardous substances above the limits

EU REACH SVHC

REACH candidate substance (CAS No.)	No substance above 0.1 wt%
-------------------------------------	----------------------------

Phoenix Contact 2026 © - all rights reserved
<https://www.phoenixcontact.com>

Phoenix Contact USA
586 Fulling Mill Road
Middletown, PA 17057, United States
(+717) 944-1300
info@phoenixcon.com