

# UKH 70-3L/N/FE-F - High-current terminal block



3076604

<https://www.phoenixcontact.com/us/products/3076604>

Please be informed that the data shown in this PDF document is generated from our online catalog. Please find the complete data in the user documentation. Our general terms of use for downloads are valid.



for direct mounting

High-current terminal block, nom. voltage: 1000 V, nominal current: 192 A, number of connections: 10, number of positions: 5, connection method: Screw connection, Rated cross section: 70 mm<sup>2</sup>, cross section: 16 mm<sup>2</sup> - 95 mm<sup>2</sup>, mounting type: direct screw connection, color: gray/blue/black-yellow

## Your advantages

- Reliable cable connection is ensured by three-point centering of the conductor in the prismatic sleeve base
- Low contact resistance of the contact surface due to ribbing
- Screw locking by means of spring-loaded elements in the clamping part

## Commercial data

Item number	3076604
Packing unit	2 pc
Minimum order quantity	2 pc
Note	Made to order (non-returnable)
Sales key	BE13
Product key	BE1311
GTIN	4046356654180
Weight per piece (including packing)	770.6 g
Weight per piece (excluding packing)	770.6 g
Customs tariff number	85369010
Country of origin	CN

# UKH 70-3L/N/FE-F - High-current terminal block



3076604

<https://www.phoenixcontact.com/us/products/3076604>

## Technical data

### Notes

#### General

Note	For a reliable contact of multi stranded conductors it is recommended to untwist multi stranded conductors.
------	---

### Product properties

Product type	High current terminal block
Number of positions	5
Number of connections	10
Number of rows	1
Potentials	5

#### Insulation characteristics

Overvoltage category	III
Degree of pollution	3

### Electrical properties

Rated surge voltage	8 kV
Maximum power dissipation for nominal condition	6.27 W

### Connection data

Number of connections per level	10
Nominal cross section	70 mm <sup>2</sup>

#### Level 1 above 1 below 1

Connection method	Screw connection
Screw thread	M8
Tightening torque	8 ... 10 Nm
Stripping length	24 mm
Internal cylindrical gage	A11
Connection in acc. with standard	IEC 60947-7-1
Conductor cross-section rigid	16 mm <sup>2</sup> ... 95 mm <sup>2</sup>
Cross section AWG	4 ... 3/0 (converted acc. to IEC)
Conductor cross-section flexible	25 mm <sup>2</sup> ... 70 mm <sup>2</sup>
Conductor cross-section, flexible [AWG]	3 ... 2/0 (converted acc. to IEC)
Conductor cross-section flexible (ferrule without plastic sleeve)	16 mm <sup>2</sup> ... 70 mm <sup>2</sup>
Flexible conductor cross-section (ferrule with plastic sleeve)	16 mm <sup>2</sup> ... 70 mm <sup>2</sup>
2 conductors with same cross section, rigid	16 mm <sup>2</sup> ... 25 mm <sup>2</sup>
2 conductors with same cross section, flexible	16 mm <sup>2</sup> ... 25 mm <sup>2</sup>
2 conductors with same cross section, flexible, with ferrule without plastic sleeve	16 mm <sup>2</sup> ... 25 mm <sup>2</sup>
Nominal cross section	70 mm <sup>2</sup>

# UKH 70-3L/N/FE-F - High-current terminal block



3076604

<https://www.phoenixcontact.com/us/products/3076604>

Nominal current	192 A
Maximum load current	192 A (in case of a 70 mm <sup>2</sup> conductor cross-section, the maximum load current must not be exceeded by the total current of all connected conductors.)
Nominal voltage	1000 V
Note	Note: Product releases, connection cross sections and notes on connecting aluminum cables can be found in the download area.

## Dimensions

Dimensional drawing	
Width	101.5 mm
Height	80 mm

## Material specifications

Color	multicolored (RAL -)
	gray (RAL 7042)
	blue (RAL 5015)
	black (RAL 9005)
	yellow (RAL 1018)
Flammability rating according to UL 94	V0
Insulating material group	I
Insulating material	PA
Static insulating material application in cold	-60 °C
Relative insulation material temperature index (Elec., UL 746 B)	130 °C
Fire protection for rail vehicles (DIN EN 45545-2) R22	HL 1 - HL 3
Fire protection for rail vehicles (DIN EN 45545-2) R23	HL 1 - HL 3
Fire protection for rail vehicles (DIN EN 45545-2) R24	HL 1 - HL 3
Fire protection for rail vehicles (DIN EN 45545-2) R26	HL 1 - HL 3
Surface flammability NFPA 130 (ASTM E 162)	passed
Specific optical density of smoke NFPA 130 (ASTM E 662)	passed
Smoke gas toxicity NFPA 130 (SMP 800C)	passed

## Electrical tests

### Surge voltage test

Test voltage setpoint	9.8 kV
Result	Test passed
Short-time withstand current 70 mm <sup>2</sup>	8.4 kA
Result	Test passed

# UKH 70-3L/N/FE-F - High-current terminal block



3076604

<https://www.phoenixcontact.com/us/products/3076604>

## Power-frequency withstand voltage

Test voltage setpoint	2.2 kV
Result	Test passed

## Mechanical properties

### Mechanical data

Open side panel	No
-----------------	----

## Mechanical tests

### Mechanical strength

Result	Test passed
--------	-------------

### Attachment on the carrier

Test force setpoint	10 N
Result	Test passed

### Test for conductor damage and slackening

Conductor cross-section/weight	25 mm <sup>2</sup> / 4.5 kg
	70 mm <sup>2</sup> /10.4 kg
	95 mm <sup>2</sup> /14 kg
Result	Test passed

## Environmental and real-life conditions

### Needle-flame test

Time of exposure	30 s
Result	Test passed

### Oscillation/broadband noise

Specification	DIN EN 50155 (VDE 0115-200):2008-03
Spectrum	Long life test category 1, class B, body mounted
Frequency	$f_1 = 5 \text{ Hz}$ to $f_2 = 150 \text{ Hz}$
ASD level	1.857 (m/s <sup>2</sup> ) <sup>2</sup> /Hz
Acceleration	0.8g
Test duration per axis	5 h
Test directions	X-, Y- and Z-axis
Result	Test passed

### Shocks

Specification	DIN EN 50155 (VDE 0115-200):2008-03
Pulse shape	Half-sine
Acceleration	5g
Shock duration	30 ms
Number of shocks per direction	3
Test directions	X-, Y- and Z-axis (pos. and neg.)

# UKH 70-3L/N/FE-F - High-current terminal block



3076604

<https://www.phoenixcontact.com/us/products/3076604>

Result	Test passed
--------	-------------

## Ambient conditions

Ambient temperature (storage/transport)	-25 °C ... 60 °C (for a short time, not exceeding 24 h, -60 °C to +70 °C)
Ambient temperature (assembly)	-5 °C ... 70 °C
Ambient temperature (actuation)	-5 °C ... 70 °C
Permissible humidity (storage/transport)	30 % ... 70 %

## Standards and regulations

Connection in acc. with standard	IEC 60947-7-1
----------------------------------	---------------

## Mounting

Mounting type	direct screw connection
---------------	-------------------------

# UKH 70-3L/N/FE-F - High-current terminal block



3076604

<https://www.phoenixcontact.com/us/products/3076604>

## Drawings

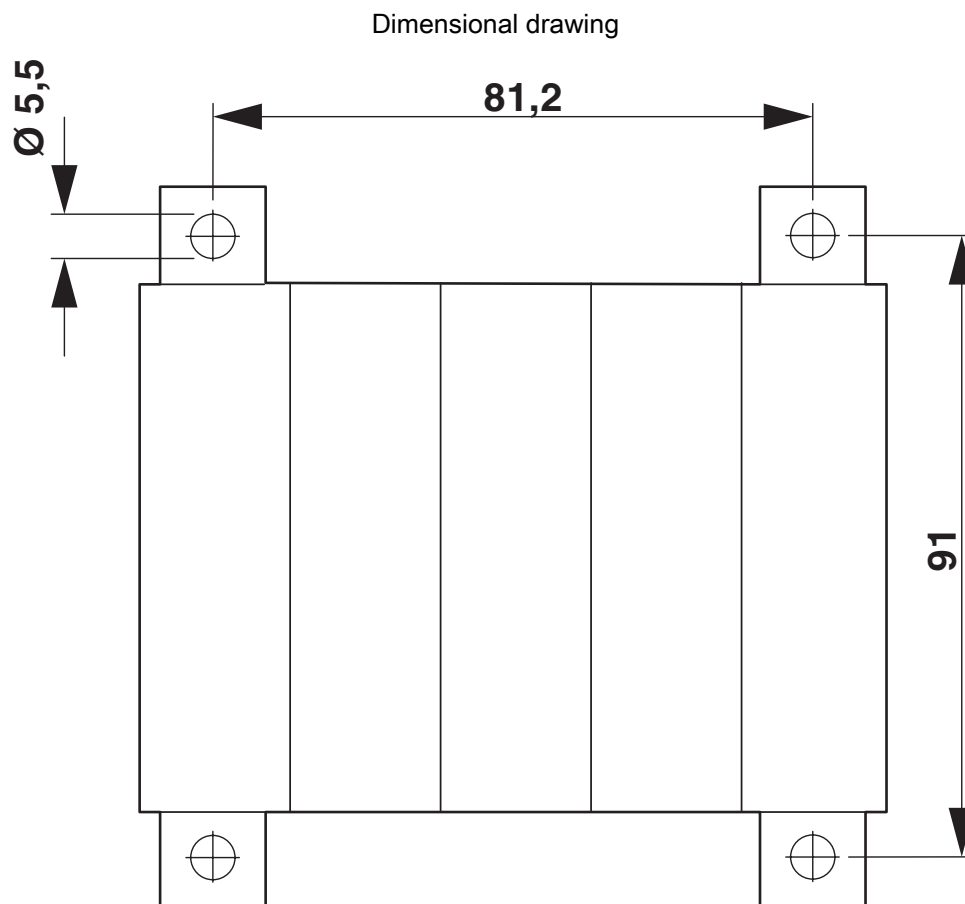

# UKH 70-3L/N/FE-F - High-current terminal block

3076604

<https://www.phoenixcontact.com/us/products/3076604>

Schematic diagram

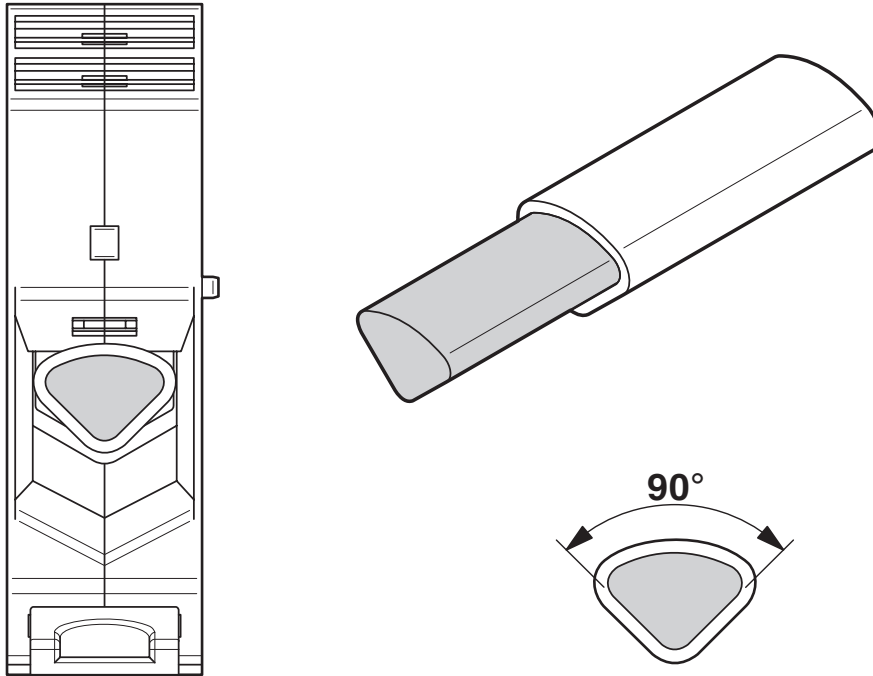

Connecting aluminum cables. Further notes can be found in the download area

Circuit diagram



# UKH 70-3L/N/FE-F - High-current terminal block



3076604

<https://www.phoenixcontact.com/us/products/3076604>

## Classifications

### UNSPSC

UNSPSC 21.0	39121400
-------------	----------

# UKH 70-3L/N/FE-F - High-current terminal block



3076604

<https://www.phoenixcontact.com/us/products/3076604>

## Environmental product compliance

### EU RoHS

Fulfills EU RoHS substance requirements	Yes, No exemptions
---	--------------------

### China RoHS

Environment friendly use period (EFUP)	EFUP-E
	No hazardous substances above the limits

### EU REACH SVHC

REACH candidate substance (CAS No.)	No substance above 0.1 wt%
-------------------------------------	----------------------------

### EF3.1 Climate Change

CO2e kg	7.37 kg CO2e
---------	--------------

Phoenix Contact 2026 © - all rights reserved  
<https://www.phoenixcontact.com>

Phoenix Contact USA  
586 Fulling Mill Road  
Middletown, PA 17057, United States  
(+717) 944-1300  
[info@phoenixcon.com](mailto:info@phoenixcon.com)