

# KEL-SNAP 24 - Snap-on frame

3063109

<https://www.phoenixcontact.com/us/products/3063109>

Please be informed that the data shown in this PDF document is generated from our online catalog. Please find the complete data in the user documentation. Our general terms of use for downloads are valid.



Size B24 snap-open frame incl. integrated mounting panel seal, for accommodating CES-B24-HFFS-PLBK or CES-B24-SFFS-PLBK sealing frames.

## Product description

Snap-on frame, large

## Commercial data

Item number	3063109
Packing unit	1 pc
Note	Made to order (non-returnable)
Sales key	NULL
Product key	AF7CBX
GTIN	4046356300889
Weight per piece (including packing)	55.04 g
Weight per piece (excluding packing)	55.04 g
Customs tariff number	39174000
Country of origin	DE

# KEL-SNAP 24 - Snap-on frame

3063109

<https://www.phoenixcontact.com/us/products/3063109>

## Technical data

### Product properties

Product type	Frame for cable sleeves
--------------	-------------------------

### Dimensions

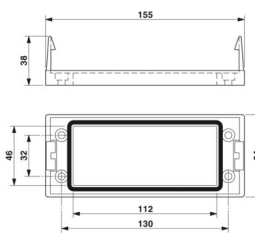
Dimensional drawing	
Width	64 mm
Height	38 mm
Length	155 mm
Drill hole distance, horizontal	32 mm
Drill hole distance, vertical	130 mm
Hole diameter	5.5 mm

### Installation dimensions

Width of the assembly cutout	35 mm
Length of the assembly cutout	112 mm

### Material specifications

Material	PA
Flammability rating according to UL 94	V0

### Environmental and real-life conditions

#### Ambient conditions

Ambient temperature (operation)	-20 °C ... 80 °C
---------------------------------	------------------

# KEL-SNAP 24 - Snap-on frame

3063109

<https://www.phoenixcontact.com/us/products/3063109>

## Drawings

Dimensional drawing

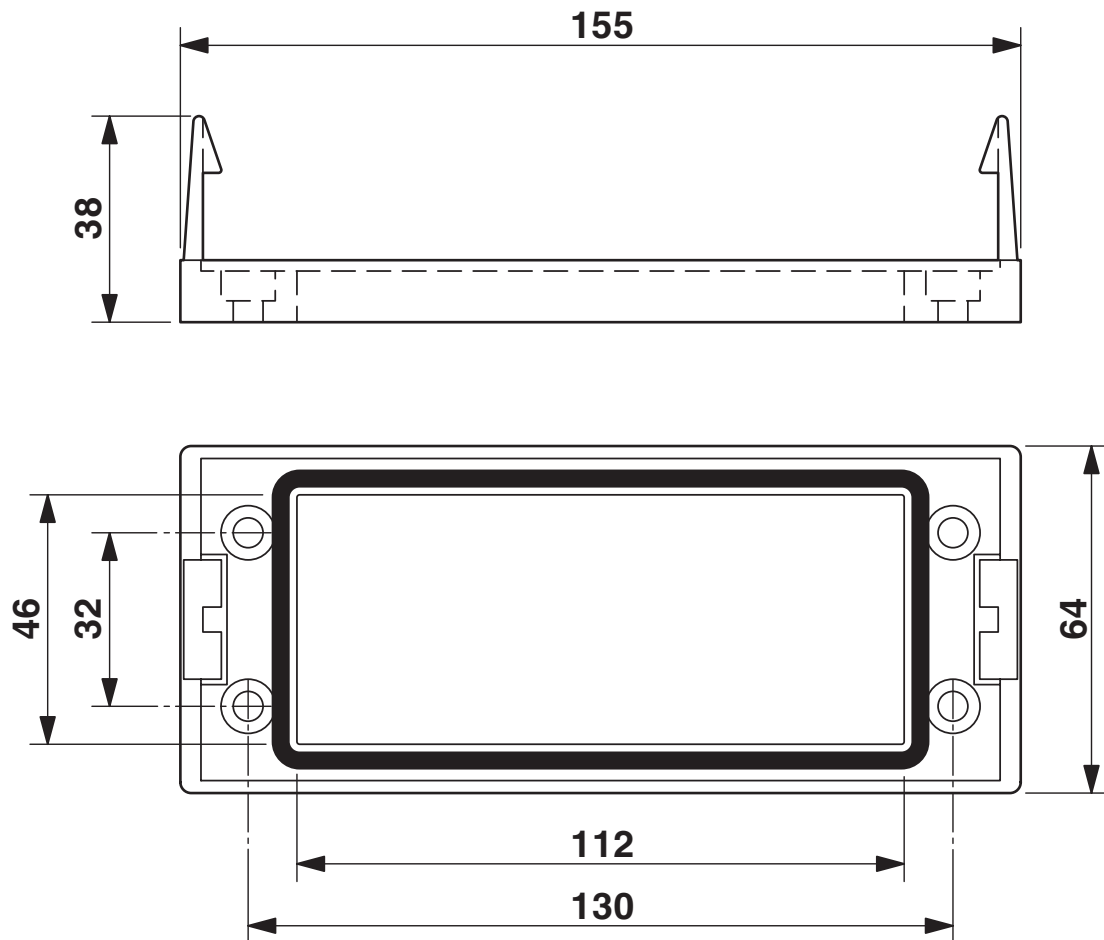

# KEL-SNAP 24 - Snap-on frame

3063109

<https://www.phoenixcontact.com/us/products/3063109>



## Classifications

### ECLASS

ECLASS-13.0	27440192
ECLASS-15.0	27440192

# KEL-SNAP 24 - Snap-on frame



3063109

<https://www.phoenixcontact.com/us/products/3063109>

## Environmental product compliance

EU REACH SVHC

REACH candidate substance (CAS No.)	No substance above 0.1 wt%
-------------------------------------	----------------------------

Phoenix Contact 2026 © - all rights reserved

<https://www.phoenixcontact.com>

Phoenix Contact USA  
586 Fulling Mill Road  
Middletown, PA 17057, United States  
(+717) 944-1300  
[info@phoenixcon.com](mailto:info@phoenixcon.com)