

UTME 4/1P - Test disconnect terminal block



3057416

<https://www.phoenixcontact.com/us/products/3057416>

Please be informed that the data shown in this PDF document is generated from our online catalog. Please find the complete data in the user documentation. Our general terms of use for downloads are valid.



Test disconnect terminal block, nom. voltage: 500 V, nominal current: 28 A, number of connections: 2, connection method: Screw/plug-in connection, Rated cross section: 4 mm², cross section: 0.14 mm² - 6 mm², mounting type: NS 35/7,5, NS 35/15, color: gray

Your advantages

- Strain relief can be snapped on if required

Commercial data

Item number	3057416
Packing unit	50 pc
Minimum order quantity	50 pc
Sales key	BE01
Product key	BE1133
GTIN	4046356520102
Weight per piece (including packing)	14.87 g
Weight per piece (excluding packing)	14.87 g
Customs tariff number	85369010
Country of origin	PL

UTME 4/1P - Test disconnect terminal block



3057416

<https://www.phoenixcontact.com/us/products/3057416>

Technical data

Notes

General

Note	With a free-hanging connection, an insulating foil has to be placed between the plug connection and electrically conductive surfaces.
------	---

Product properties

Product type	Test disconnect terminal block
Number of connections	2
Number of rows	1
Potentials	1

Insulation characteristics

Overvoltage category	III
----------------------	-----

Electrical properties

Rated surge voltage	6 kV
Maximum power dissipation for nominal condition	1.02 W

Connection data

Number of connections per level	2
Nominal cross section	4 mm ²
Connection method	Screw/plug-in connection
Screw thread	M3
Tightening torque	0.6 ... 0.8 Nm
Stripping length	9 mm
Internal cylindrical gage	A4
Connection in acc. with standard	IEC 60947-7-1
Conductor cross-section rigid	0.14 mm ² ... 6 mm ²
Cross section AWG	26 ... 10 (converted acc. to IEC)
Conductor cross-section flexible	0.14 mm ² ... 6 mm ²
Conductor cross-section, flexible [AWG]	26 ... 10 (converted acc. to IEC)
Conductor cross-section flexible (ferrule without plastic sleeve)	0.14 mm ² ... 4 mm ²
Flexible conductor cross-section (ferrule with plastic sleeve)	0.14 mm ² ... 4 mm ²
2 conductors with same cross section, rigid	0.14 mm ² ... 1.5 mm ²
2 conductors with same cross section, flexible	0.14 mm ² ... 1.5 mm ²
2 conductors with same cross section, flexible, with ferrule without plastic sleeve	0.14 mm ² ... 1.5 mm ²
2 conductors with the same cross section, flexible, with TWIN ferrule with plastic sleeve	0.5 mm ² ... 2.5 mm ²
Nominal cross section	4 mm ²
Nominal current	28 A
Maximum load current	28 A (bei 6 mm ² Leiterquerschnitt starr)

UTME 4/1P - Test disconnect terminal block



3057416

<https://www.phoenixcontact.com/us/products/3057416>

Nominal voltage	500 V
-----------------	-------

Dimensions

Width	6.2 mm
End cover width	2.2 mm
Height	71.1 mm
Depth on NS 35/7,5	49.5 mm
Depth on NS 35/15	57 mm

Material specifications

Color	gray (RAL 7042)
Flammability rating according to UL 94	V0
Insulating material group	I
Insulating material	PA
Static insulating material application in cold	-60 °C
Relative insulation material temperature index (Elec., UL 746 B)	130 °C
Fire protection for rail vehicles (DIN EN 45545-2) R22	HL 1 - HL 3
Fire protection for rail vehicles (DIN EN 45545-2) R23	HL 1 - HL 3
Fire protection for rail vehicles (DIN EN 45545-2) R24	HL 1 - HL 3
Fire protection for rail vehicles (DIN EN 45545-2) R26	HL 1 - HL 3
Surface flammability NFPA 130 (ASTM E 162)	passed
Specific optical density of smoke NFPA 130 (ASTM E 662)	passed
Smoke gas toxicity NFPA 130 (SMP 800C)	passed

Electrical tests

Surge voltage test

Test voltage setpoint	7.3 kV
Result	Test passed
Short-time withstand current 4 mm ²	0.5 kA
	0.15 kA
	1.25 kA
Result	Test passed

Mechanical properties

Mechanical data

Open side panel	Yes
-----------------	-----

Mechanical tests

Attachment on the carrier

DIN rail/fixing support	NS 35
Test force setpoint	1 N
Result	Test passed

UTME 4/1P - Test disconnect terminal block



3057416

<https://www.phoenixcontact.com/us/products/3057416>

Environmental and real-life conditions

Needle-flame test

Time of exposure	30 s
Result	Test passed

Oscillation/broadband noise

Specification	DIN EN 50155 (VDE 0115-200):2008-03
Spectrum	Long life test category 1, class B, body mounted
Frequency	$f_1 = 5 \text{ Hz}$ to $f_2 = 150 \text{ Hz}$
ASD level	0.02g ² /Hz
Acceleration	0.8g
Test duration per axis	5 h
Test directions	X-, Y- and Z-axis
Result	Test passed

Shocks

Specification	DIN EN 50155 (VDE 0115-200):2008-03
Pulse shape	Half-sine
Acceleration	5g
Shock duration	30 ms
Number of shocks per direction	3
Test directions	X-, Y- and Z-axis (pos. and neg.)
Result	Test passed

Ambient conditions

Ambient temperature (operation)	-60 °C ... 110 °C (Operating temperature range incl. self-heating; for max. short-term operating temperature, see RTI Elec.)
Ambient temperature (storage/transport)	-25 °C ... 60 °C (for a short time, not exceeding 24 h, -60 °C to +70 °C)
Ambient temperature (assembly)	-5 °C ... 70 °C
Ambient temperature (actuation)	-5 °C ... 70 °C
Permissible humidity (operation)	20 % ... 90 %
Permissible humidity (storage/transport)	30 % ... 70 %

Standards and regulations

Connection in acc. with standard	IEC 60947-7-1
----------------------------------	---------------

Mounting

Mounting type	NS 35/7,5
	NS 35/15
Assembly note	For isolation purposes, the screw head in NS 35/7,5 DIN rails may not exceed a height of 5 mm including the washer.

UTME 4/1P - Test disconnect terminal block

3057416

<https://www.phoenixcontact.com/us/products/3057416>

Drawings

Circuit diagram

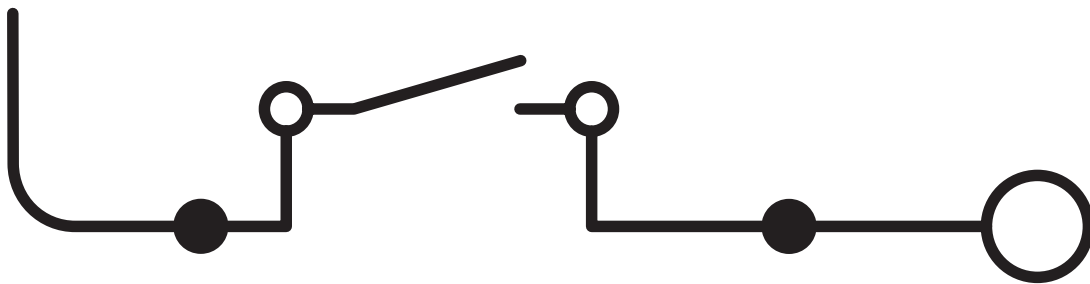

Circuit diagram



UTME 4/1P - Test disconnect terminal block



3057416

<https://www.phoenixcontact.com/us/products/3057416>

Circuit diagram

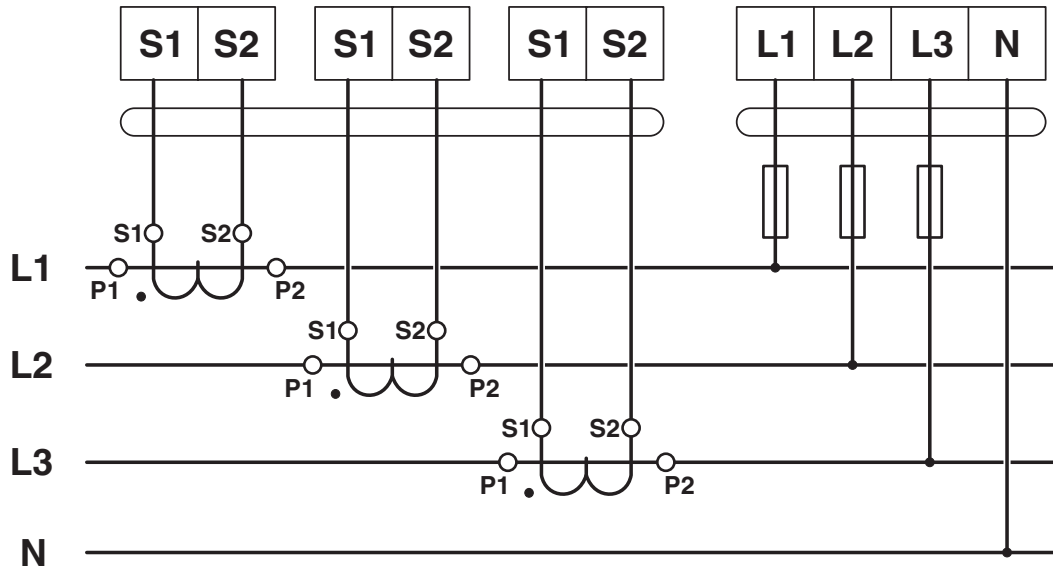

UTME 4/1P - Test disconnect terminal block



3057416

<https://www.phoenixcontact.com/us/products/3057416>

Approvals

To download certificates, visit the product detail page: <https://www.phoenixcontact.com/us/products/3057416>

 **CSA**
Approval ID: 13631

 **EAC**
Approval ID: KZ7500651131219505

 **cULus Recognized**
Approval ID: E60425

	Nominal voltage U_N	Nominal current I_N	Cross section AWG	Cross section mm^2
B	300 V	25 A	26 - 10	-
C	300 V	25 A	26 - 10	-
D	600 V	5 A	26 - 10	-

 **CSA**
Approval ID: 13631

UTME 4/1P - Test disconnect terminal block



3057416

<https://www.phoenixcontact.com/us/products/3057416>

Classifications

ECLASS

ECLASS-13.0	27250109
ECLASS-15.0	27250109

ETIM

ETIM 10.0	EC000902
-----------	----------

UNSPSC

UNSPSC 21.0	39121400
-------------	----------

UTME 4/1P - Test disconnect terminal block



3057416

<https://www.phoenixcontact.com/us/products/3057416>

Environmental product compliance

EU RoHS

Fulfills EU RoHS substance requirements	Yes
Exemption	6(c)

China RoHS

Environment friendly use period (EFUP)	EFUP-50
	An article-related China RoHS declaration table can be found in the download area for the respective article under "Manufacturer declaration". For all articles with EFUP-E, no China RoHS declaration table issued and required.

EU REACH SVHC

REACH candidate substance (CAS No.)	Lead(CAS: 7439-92-1)
SCIP	bb9aa50a-d530-426b-b8c7-a27cb7125571

EF3.1 Climate Change

CO2e kg	0.036 kg CO2e
---------	---------------

Phoenix Contact 2026 © - all rights reserved
<https://www.phoenixcontact.com>

Phoenix Contact USA
586 Fulling Mill Road
Middletown, PA 17057, United States
(+717) 944-1300
info@phoenixcon.com