

UW 4-POT-SCM/S - Panel feed-through terminal block



3056909

<https://www.phoenixcontact.com/us/products/3056909>

Please be informed that the data shown in this PDF document is generated from our online catalog. Please find the complete data in the user documentation. Our general terms of use for downloads are valid.



Panel feed-through terminal block, connection method: Screw connection with tension sleeve, Spade connection, number of positions: 1, load current: 18 A, cross section: 0.2 mm² - 6 mm², connection direction of the conductor to plug-in direction: 0 °, width: 8.1 mm, color: gray

Your advantages

- Well-known connection principle allows worldwide use
- Low temperature rise, thanks to maximum contact force
- Tool-free snap-in principle enables easy mounting on the device panel
- Automatic panel thickness compensation enables universal use
- Reliable seal even with low-viscosity molding compounds

Commercial data

Item number	3056909
Packing unit	50 pc
Minimum order quantity	50 pc
Note	Made to order (non-returnable)
Sales key	AA28
Product key	AA1ADB
GTIN	4046356513883
Weight per piece (including packing)	7.57 g
Weight per piece (excluding packing)	6.051 g
Customs tariff number	85369010
Country of origin	CN

UW 4-POT-SCM/S - Panel feed-through terminal block



3056909

<https://www.phoenixcontact.com/us/products/3056909>

Technical data

Product properties

Product type	Panel feed-through terminal block
Product family	UW 4-POT-SCM
Number of positions	1
Pitch	8.1 mm
Number of connections	2
Number of rows	1
Number of potentials	1
Potentials	1

Insulation characteristics

Overvoltage category	III
Degree of pollution	3

Electrical properties

Properties

Nominal current I_N	18 A
Nominal voltage U_N	500 V
Rated voltage (III/3)	500 V
Rated surge voltage (III/3)	6 kV

Connection data

Connection technology

Connector system	UW 4
Nominal cross section	4 mm ²

Conductor connection exterior

Connection method	Screw connection with tension sleeve
Connection direction of the conductor to plug-in direction	0 °
Conductor cross-section rigid	0.2 mm ² ... 6 mm ²
Conductor cross-section flexible	0.2 mm ² ... 4 mm ²
Conductor cross-section, flexible, with ferrule, without plastic sleeve	0.25 mm ² ... 4 mm ²
Conductor cross-section, flexible, with ferrule, with plastic sleeve	0.25 mm ² ... 4 mm ²
2 conductors with same cross section, rigid	0.2 mm ² ... 1.5 mm ²
2 conductors with same cross section, flexible	0.2 mm ² ... 1.5 mm ²
2 conductors with same cross section, flexible, with ferrule without plastic sleeve	0.25 mm ² ... 1.5 mm ²
2 conductors with the same cross section, flexible, with TWIN ferrule with plastic sleeve	0.5 mm ² ... 2.5 mm ²
Internal cylindrical gage	A4
Stripping length	10 mm

UW 4-POT-SCM/S - Panel feed-through terminal block



3056909

<https://www.phoenixcontact.com/us/products/3056909>

Tightening torque	0.6 Nm ... 0.8 Nm
Conductor connection interior	
Connection method	Spade connection
Connection direction of the conductor to plug-in direction	0 °

Mounting

Panel thickness	1 mm...4 mm
-----------------	-------------

Material specifications

Material data - contact

Note	WEEE/RoHS-compliant, free of whiskers according to IEC 60068-2-82/JEDEC JESD 201
Contact material	Cu alloy
Surface characteristics	tin-plated

Material data - housing

Color (Housing)	gray (7042)
Insulating material	PA
Insulating material group	I
CTI according to IEC 60112	600
Flammability rating according to UL 94	V0
Glow wire flammability index GWFI according to EN 60695-2-12	850
Glow wire ignition temperature GWIT according to EN 60695-2-13	775
Temperature for the ball pressure test according to EN 60695-10-2	125 °C

Notes

Safety note

Safety note	<ul style="list-style-type: none">• Only electrically qualified personnel may install and operate the product. To recognize and prevent danger, the qualified personnel must be familiar with the basics of electrical engineering.• Observe the technical data provided here and refer to the documents listed under "Downloads". The download area contains important information, such as installation notes, technical drawings, and 3D data.• To maintain the nominal voltage, cast the terminals on the inside.
-------------	---

Dimensions

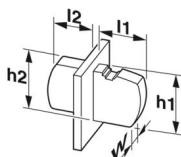
Dimensional drawing	
---------------------	--

UW 4-POT-SCM/S - Panel feed-through terminal block



3056909

<https://www.phoenixcontact.com/us/products/3056909>

Pitch	8.1 mm
Width [w]	8.1 mm

External dimensions

Height [h1]	23.5 mm
Length [l1]	23.6 mm

Internal dimensions

Height [h2]	24.8 mm
Length [l2]	20.8 mm

Mechanical tests

Test for conductor damage and slackening

Specification	IEC 60947-7-1:2009-04
Result	Test passed

Pull-out test

Specification	IEC 60947-7-1:2009-04
Conductor cross-section/conductor type/tractive force setpoint/actual value	0.25 mm ² / solid / > 10 N
	0.25 mm ² / flexible / > 10 N
	6 mm ² / solid / > 80 N
	4 mm ² / flexible / > 60 N

Electrical tests

Temperature-rise test

Specification	IEC 60947-7-1:2009-04
Requirement temperature-rise test	Increase in temperature ≤ 45 K

Short-time withstand current

Specification	IEC 60947-7-1:2009-04
---------------	-----------------------

Air clearances and creepage distances | 1. Insulation coordination

Application	without spacer plate
Specification	IEC 60947-7-1:2009-04
Insulating material group	I
Comparative tracking index (IEC 60112)	CTI 600
Rated insulation voltage (III/3)	500 V
Rated surge voltage (III/3)	6 kV
minimum clearance value - non-homogenous field (III/3)	5.5 mm
minimum creepage distance (III/3)	6.3 mm

Air clearances and creepage distances | 2. Insulation coordination

Application	with spacer plate
Specification	IEC 60947-7-1:2009-04
Insulating material group	I
Comparative tracking index (IEC 60112)	CTI 600

UW 4-POT-SCM/S - Panel feed-through terminal block



3056909

<https://www.phoenixcontact.com/us/products/3056909>

Rated insulation voltage (III/3)	800 V
Rated surge voltage (III/3)	8 kV
minimum clearance value - non-homogenous field (III/3)	8 mm
minimum creepage distance (III/3)	10 mm

Environmental and real-life conditions

Glow-wire test

Specification	IEC 60695-2-11:2000-10
Temperature	960 °C
Time of exposure	30 s

Ambient conditions

Ambient temperature (storage/transport)	-40 °C ... 70 °C
Relative humidity (storage/transport)	30 % ... 70 %
Ambient temperature (assembly)	-5 °C ... 100 °C
Ambient temperature (operation)	-40 °C ... 100 °C (Depending on the current carrying capacity/derating curve)

Ambient conditions

Ambient temperature (operation)	-40 °C ... 100 °C (Depending on the current carrying capacity/derating curve)
Ambient temperature (storage/transport)	-40 °C ... 70 °C
Relative humidity (storage/transport)	30 % ... 70 %
Ambient temperature (assembly)	-5 °C ... 100 °C

Packaging specifications

Type of packaging	packed in cardboard
-------------------	---------------------

UW 4-POT-SCM/S - Panel feed-through terminal block

3056909

<https://www.phoenixcontact.com/us/products/3056909>

Drawings

Dimensional drawing

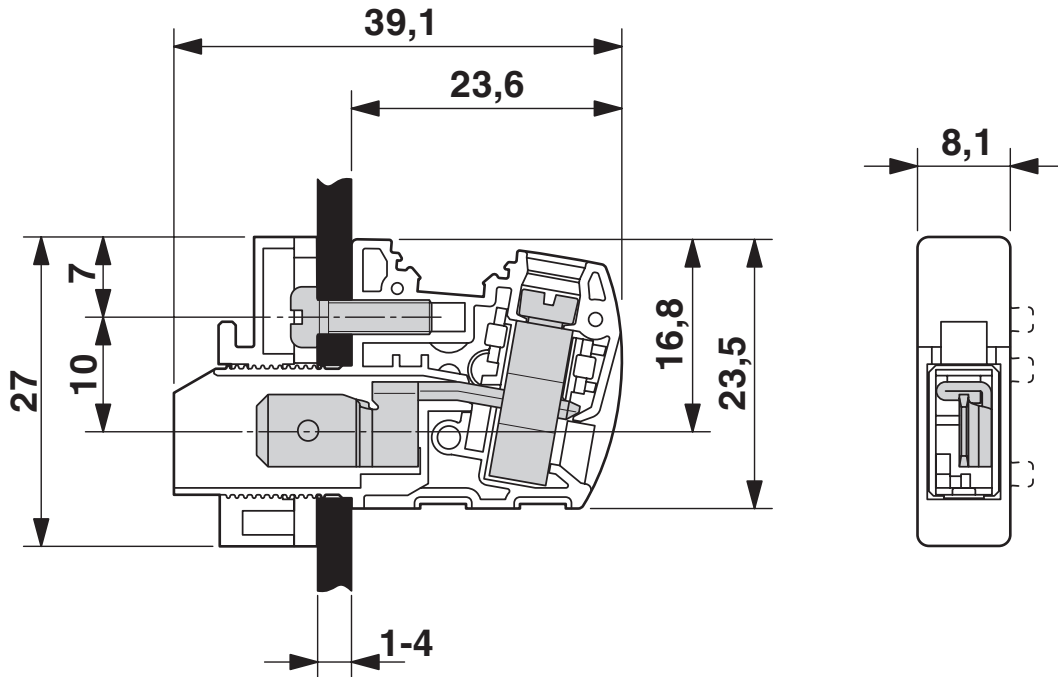

Dimensional drawing

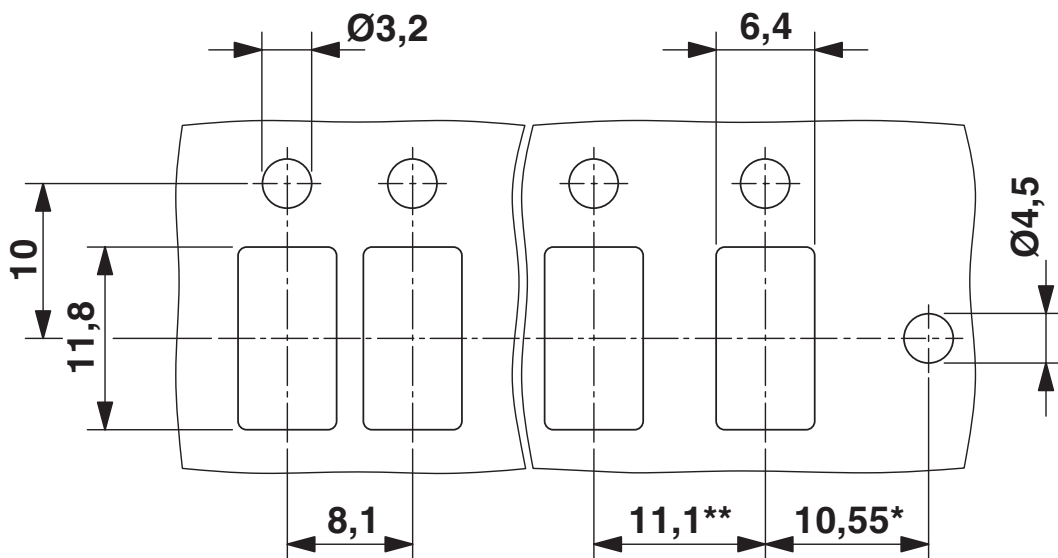

* Only when using the UW...-F flange plate

** Dimensions when using the DP-UW... spacer plate

UW 4-POT-SCM/S - Panel feed-through terminal block



3056909

<https://www.phoenixcontact.com/us/products/3056909>

Approvals

To download certificates, visit the product detail page: <https://www.phoenixcontact.com/us/products/3056909>

 CSA Approval ID: 13631				
	Nominal voltage U_N	Nominal current I_N	Cross section AWG	Cross section mm^2
B	300 V	30 A	24 - 10	-
C	300 V	30 A	24 - 10	-
D	600 V	5 A	24 - 10	-

 cULus Recognized Approval ID: E60425-20100423				
	Nominal voltage U_N	Nominal current I_N	Cross section AWG	Cross section mm^2
B	300 V	30 A	24 - 10	-
C	300 V	30 A	24 - 10	-
D	600 V	5 A	24 - 10	-

UW 4-POT-SCM/S - Panel feed-through terminal block



3056909

<https://www.phoenixcontact.com/us/products/3056909>

Classifications

ECLASS

ECLASS-13.0	27141134
ECLASS-15.0	27141134

ETIM

ETIM 10.0	EC001283
-----------	----------

UNSPSC

UNSPSC 21.0	39121400
-------------	----------

UW 4-POT-SCM/S - Panel feed-through terminal block



3056909

<https://www.phoenixcontact.com/us/products/3056909>

Environmental product compliance

EU RoHS

Fulfills EU RoHS substance requirements	Yes, No exemptions
---	--------------------

China RoHS

Environment friendly use period (EFUP)	EFUP-E
	No hazardous substances above the limits

EU REACH SVHC

REACH candidate substance (CAS No.)	No substance above 0.1 wt%
-------------------------------------	----------------------------

Phoenix Contact 2026 © - all rights reserved
<https://www.phoenixcontact.com>

Phoenix Contact USA
586 Fulling Mill Road
Middletown, PA 17057, United States
(+717) 944-1300
info@phoenixcon.com