

PLC-RSC- 24UC/ 1/S/H - Switch

2982236

<https://www.phoenixcontact.com/us/products/2982236>



Please be informed that the data shown in this PDF document is generated from our online catalog. Please find the complete data in the user documentation. Our general terms of use for downloads are valid.



PLC-INTERFACE with switch (operation by hand) for the "Manual, Zero, and Automatic" functions, with screw connection and integrated power contact relay, for mounting on DIN rail NS 35/7,5, 1 N/O contact, input voltage 24 V AC/DC

Your advantages

- Just 6.2 mm wide
- Safe isolation between coil and contact side
- Max. switching current of 6 A
- Floating confirmation contact
- Screw- and Push-in connection

Commercial data

Item number	2982236
Packing unit	10 pc
Minimum order quantity	10 pc
Sales key	C461
Product key	DK622E
GTIN	4046356093941
Weight per piece (including packing)	38.07 g
Weight per piece (excluding packing)	39 g
Customs tariff number	85364190
Country of origin	DE

PLC-RSC- 24UC/ 1/S/H - Switch



2982236

<https://www.phoenixcontact.com/us/products/2982236>

Technical data

Product properties

Product type	Relay Module
Product family	PLC-INTERFACE
Application	Palm switch
Operating mode	100% operating factor

Insulation characteristics: Air clearances and creepage distances between the power circuits

Overvoltage category	III
Pollution degree	3

Data management status

Date of last data management	01.04.2026
------------------------------	------------

Electrical properties

Maximum power dissipation for nominal condition	0.26 W
---	--------

Air clearances and creepage distances between the power circuits

Rated insulation voltage	250 V AC
Rated surge voltage	6 kV

Input data

Coil side

Nominal input voltage U_N	24 V AC/DC
Input voltage range	19.4 V AC/DC ... 33.6 V AC/DC (20 °C)
Nominal voltage (plugged-in electromechanical relay)	24 V DC
Drive and function	monostable
Drive (polarity)	polarized
Typical input current at U_N	11 mA
Typical response time	6 ms
Typical release time	15 ms
Protective circuit	Bridge rectifier; Bridge rectifier
Operating voltage display	Yellow LED

Output data

Switching

Contact switching type	1 N/O contact
Type of switch contact	Single contact
Contact connection type	Power contact
Contact material	AgSnO, hard gold-plated
Maximum switching voltage	250 V AC/DC
Minimum switching voltage	5 V (100 mA)
Limiting continuous current	6 A

PLC-RSC- 24UC/ 1/S/H - Switch



2982236

<https://www.phoenixcontact.com/us/products/2982236>

Maximum inrush current	on request
Min. switching current	10 mA (12 V)
Short-circuit current	200 A (conditional short-circuit current)
Interrupting rating (ohmic load) max.	140 W (at 24 V DC)
	20 W (at 48 V DC)
	18 W (at 60 V DC)
	23 W (at 110 V DC)
	40 W (at 220 V DC)
	1500 VA (for 250 V AC)
Output fuse	4 A gL/gG NEOZED

Connection data

Connection method	Screw connection
Stripping length	8 mm
Screw thread	M3
Conductor cross-section rigid	0.14 mm ² ... 2.5 mm ²
Conductor cross-section flexible	0.14 mm ² ... 2.5 mm ²
	0.2 mm ² ... 2.5 mm ² (Single ferrule)
	2x 0.5 mm ² ... 1.5 mm ² (TWIN ferrule)
Conductor cross-section AWG	26 ... 14
Tightening torque	0.45 Nm ... 0.55 Nm (Usually these terminal blocks must be supported during conductor connection (held by one hand, supported on the housing))

Dimensions

Item dimensions

Width	6.2 mm
Height	80 mm
Depth	90 mm

Material specifications

Color	gray (RAL 7042)
Flammability rating according to UL 94 (Housing)	V0 (Housing)

Environmental and real-life conditions

Ambient conditions

Degree of protection (Relay base)	IP20 (Relay base)
Ambient temperature (operation)	-20 °C ... 60 °C
Ambient temperature (storage/transport)	-20 °C ... 85 °C

Approvals

CE

Certificate	CE-compliant
-------------	--------------

PLC-RSC- 24UC/ 1/S/H - Switch



2982236

<https://www.phoenixcontact.com/us/products/2982236>

UKCA

Certificate	UKCA-compliant
-------------	----------------

Shipbuilding approval

Certificate	TAE0000196
-------------	------------

Corrosive gas test

Identification	ISA-S71.04. G3 Harsh Group
	EN 60068-2-60

Shipbuilding data

Temperature	D
Humidity	A
Vibration	B/C
EMC	B
Enclosure	Required protection according to the Rules shall be provided upon installation on board

EMC data

Electromagnetic compatibility	Conformance with EMC directive
Low Voltage Directive	Conformance with Low Voltage Directive

Standards and regulations

Air clearances and creepage distances between the power circuits

Standards/regulations	IEC 60664
	IEC 60947-5-1

Mounting

Mounting type	DIN rail mounting
Assembly note	in rows with zero spacing
Mounting position	any

PLC-RSC- 24UC/ 1/S/H - Switch

2982236

<https://www.phoenixcontact.com/us/products/2982236>



Drawings

Application drawing

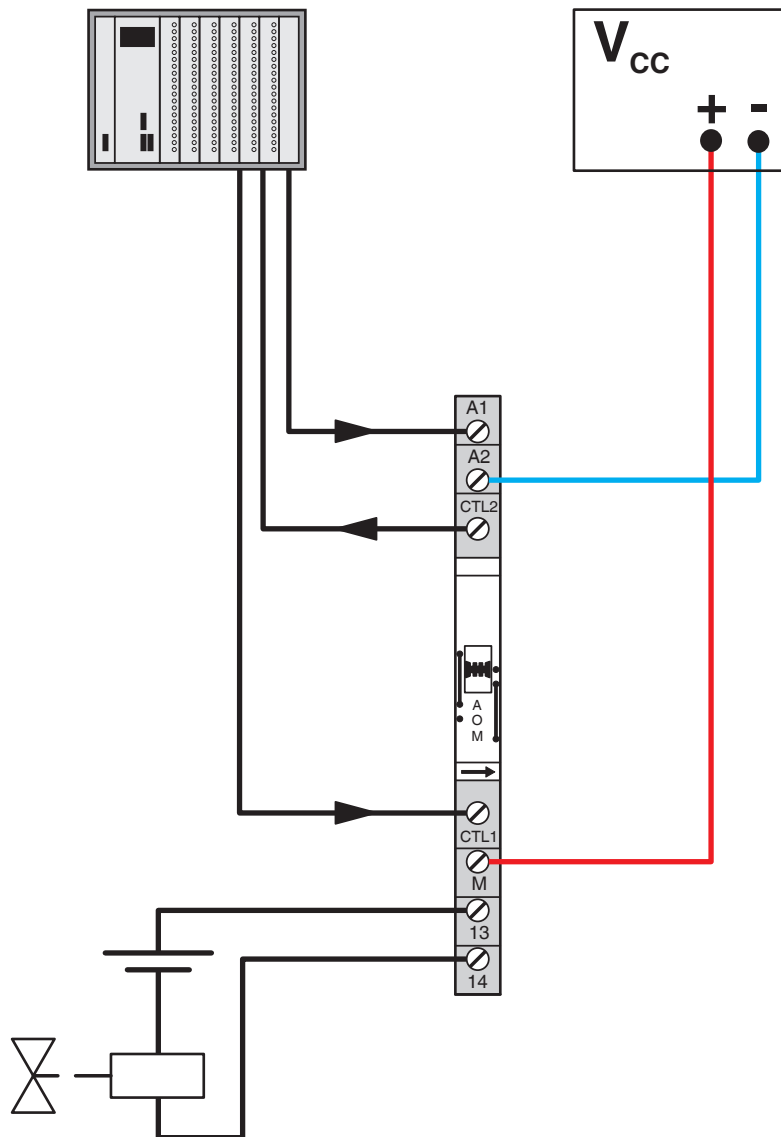

PLC-RSC- 24UC/ 1/S/H - Switch

2982236

<https://www.phoenixcontact.com/us/products/2982236>



Diagram

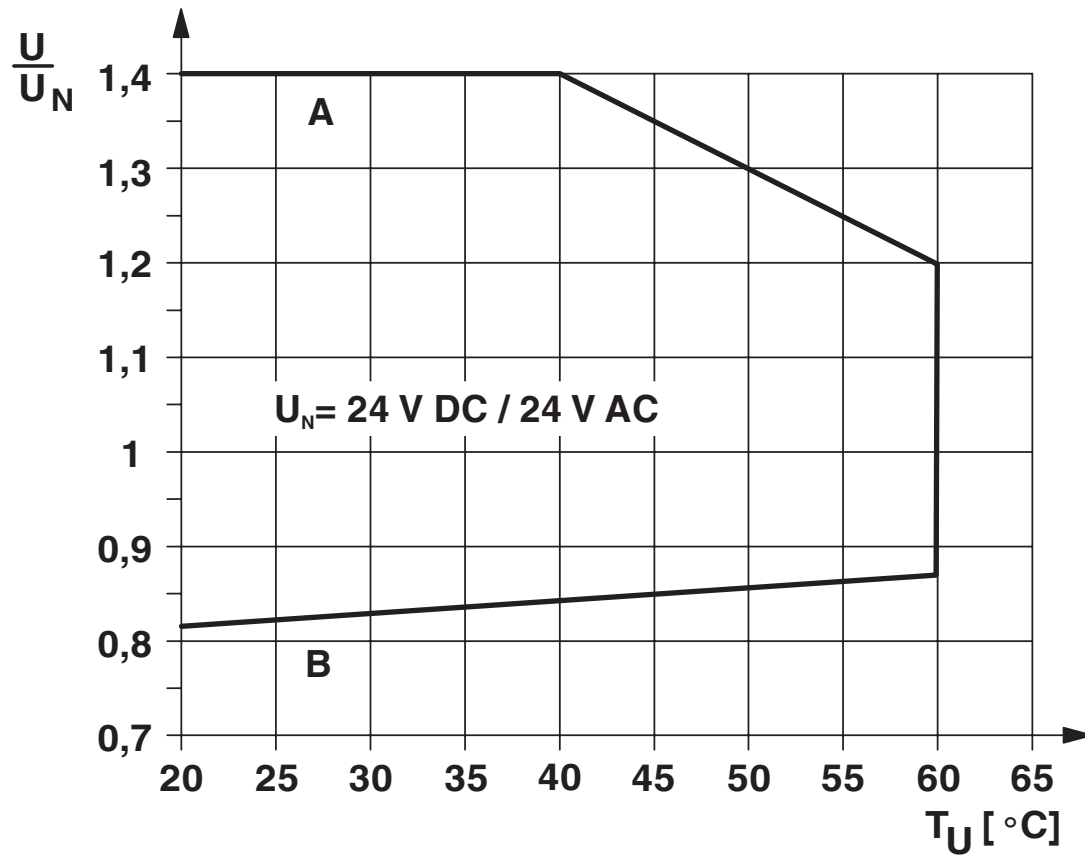

Diagram



① 250 V AC, ohmic load

Electrical service life

Diagram



Permissible humidity for operation and storage.

The maximum permissible ambient temperature as specified in the data sheet must be observed.

Area A: Ice buildup at ambient temperatures $\leq 0^{\circ}\text{C}$ must be prevented

Area B: Condensation at ambient temperatures $> 0^{\circ}\text{C}$ must be prevented

On 30 full days that are naturally distributed across an entire year, a humidity level of 95% is permissible at an ambient temperature $\leq 25^{\circ}\text{C}$.

Circuit diagram

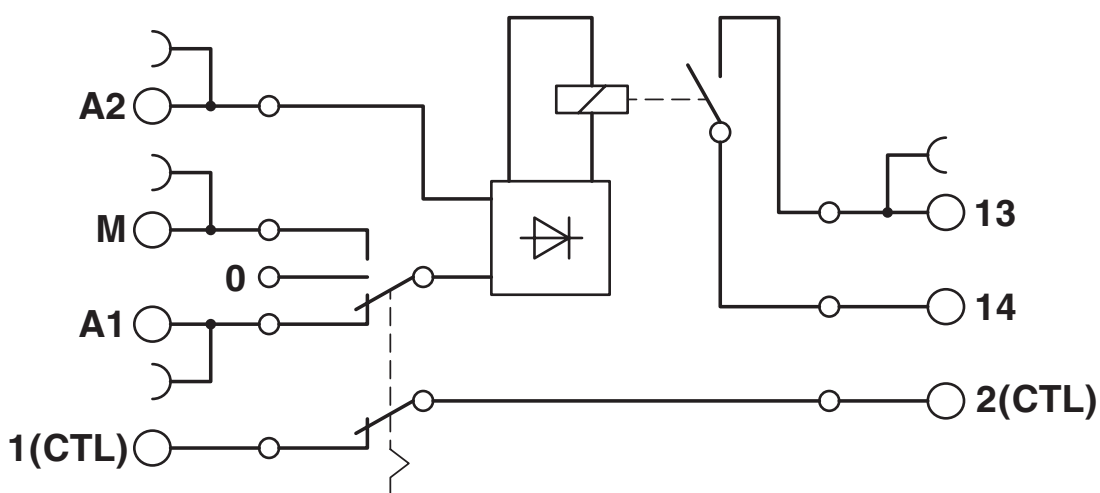

PLC-RSC- 24UC/ 1/S/H - Switch



2982236

<https://www.phoenixcontact.com/us/products/2982236>

Approvals

To download certificates, visit the product detail page: <https://www.phoenixcontact.com/us/products/2982236>



EAC

Approval ID: RU*DE.*08.B.01517/19



cULus Listed

Approval ID: E140324



cULus Listed

Approval ID: E140324



cULus Listed

Approval ID: E140324

DNV

Approval ID: TAE0000196

PLC-RSC- 24UC/ 1/S/H - Switch

2982236

<https://www.phoenixcontact.com/us/products/2982236>



Classifications

ECLASS

ECLASS-13.0	27371601
ECLASS-15.0	27371601

ETIM

ETIM 10.0	EC001437
-----------	----------

UNSPSC

UNSPSC 21.0	39122300
-------------	----------

PLC-RSC- 24UC/ 1/S/H - Switch



2982236

<https://www.phoenixcontact.com/us/products/2982236>

Environmental product compliance

EU RoHS

Fulfills EU RoHS substance requirements	Yes
Exemption	7(a), 7(c)-I

China RoHS

Environment friendly use period (EFUP)	EFUP-50
	An article-related China RoHS declaration table can be found in the download area for the respective article under "Manufacturer declaration". For all articles with EFUP-E, no China RoHS declaration table issued and required.

EU REACH SVHC

REACH candidate substance (CAS No.)	Lead(CAS: 7439-92-1)
SCIP	4a27fa08-6641-4d1d-addc-e98dc867e18c

Phoenix Contact 2026 © - all rights reserved
<https://www.phoenixcontact.com>

Phoenix Contact USA
586 Fulling Mill Road
Middletown, PA 17057, United States
(+717) 944-1300
info@phoenixcon.com