

PSR-SPP- 24DC/ESD/5X1/1X2/ T 2 - Safety relays



2981198

<https://www.phoenixcontact.com/us/products/2981198>

Please be informed that the data shown in this PDF document is generated from our online catalog. Please find the complete data in the user documentation. Our general terms of use for downloads are valid.



The figure shows a version of the product

Safety relay for emergency stop and safety door monitoring up to SIL 3 or Cat. 4, PL e in accordance with EN ISO 13849, automatic or manual activation, 3 N/O contacts, 1 N/C contact, 2 N/O contacts with a fixed dropout delay of 2 s, plug-in Push-in terminal block

Your advantages

- Up to Cat. 3/PL d in accordance with EN ISO 13849-1, SIL 2 for delayed contacts
- Up to Cat. 4/PL e in accordance with ISO 13849-1, SIL 3 in accordance with EN IEC 62061, SIL 3 in accordance with IEC 61508 for undelayed contacts
- 1- and 2-channel control
- 3 undelayed and 2 dropout delay contacts
- Fixed delay times of 2 s
- For emergency stop and safety door monitoring, plus evaluation of light grids

Commercial data

Item number	2981198
Packing unit	1 pc
Note	Made to order (non-returnable)
Sales key	DN01
Product key	DNA132
GTIN	4017918956745
Weight per piece (including packing)	482.2 g
Weight per piece (excluding packing)	463.9 g
Customs tariff number	85371098
Country of origin	DE

Technical data

Notes

Note on application

Note on application	Only for industrial use
---------------------	-------------------------

Utilization restriction

EMC note	EMC: class A product, see manufacturer's declaration in the download area
----------	---

Product properties

Product type	Safety relays
Product family	PSRclassic
Application	Emergency stop Safety door Light grid
Control	1 and 2 channel
Mechanical service life	10x 10 ⁶ cycles
Relay type	Electromechanical relay with force-guided contacts in accordance with IEC/EN 61810-3

Insulation characteristics: Air clearances and creepage distances between the power circuits

Overvoltage category	III
Degree of pollution	2

Electrical properties

Maximum power dissipation for nominal condition	3.6 W
Nominal operating mode	100% operating factor

Air clearances and creepage distances between the power circuits

Rated insulation voltage	250 V AC
Rated surge voltage/insulation	Basic insulation 4 kV: between all current paths and housing Safe isolation, reinforced insulation 6 kV: between 13/14, 23/24, 33/34, and the remaining current paths between 13/14, 23/24, 33/34 among one another

Input data

General

Rated control circuit supply voltage U_S	24 V DC -15 % / +10 %
Power consumption at U_S	typ. 3.6 W
Rated control supply current I_S	typ. 150 mA
Inrush current	200 mA (at U_S) < 40 mA (with U_S/I_x to S10) < 150 mA (with U_S/I_x to S12) > -60 mA (with U_S/I_x to S22)

PSR-SPP- 24DC/ESD/5X1/1X2/ T 2 - Safety relays



2981198

<https://www.phoenixcontact.com/us/products/2981198>

Current consumption	< 40 mA (with U_s/I_x to S34)
	< 40 mA (with U_s/I_x to S35)
	< 40 mA (with U_s/I_x to S10)
	< 40 mA (with U_s/I_x to S12)
	> -40 mA (with U_s/I_x to S22)
	0 mA (with U_s/I_x to S34)
Voltage at input/start and feedback circuit	< 5 mA (with U_s/I_x to S35)
	24 V DC -15 % / +10 %
Filter time	1 ms (at A1 in the event of voltage dips at U_s)
	max. 1.5 ms (at S10, S12; test pulse width)
	7.5 ms (at S10, S12; test pulse rate)
	Test pulse rate = 5 x Test pulse width
Typical response time	< 600 ms (automatic start)
	< 70 ms (manual start)
Typ. starting time with U_s	< 600 ms (when controlled via A1)
Typical release time	< 20 ms (when controlled via S11/S12 and S21/S22)
	< 20 ms (when controlled via A1)
Concurrency	∞
Recovery time	< 1 s
Delay time	K3(t), K4(t) fixed depending on model
Maximum switching frequency	0.5 Hz
Protective circuit	Surge protection; Suppressor diode
Max. permissible overall conductor resistance	approx. 11 Ω (Input and start circuits at U_s)
Operating voltage display	1 x LED (green)
Status display	4 x LED (green)

Output data

Contact switching type	5 enabling current paths
	1 signaling current path
Contact material	AgSnO ₂
Maximum switching voltage	250 V AC/DC (Observe the load curve)
Minimum switching voltage	5 V AC/DC
Limiting continuous current	6 A (N/O contact, pay attention to the derating)
	6 A (N/C contact)
Maximum inrush current	20 A ($\Delta t \leq \text{[trapezoidal pulse symbol]} \text{ ms}$, undelayed contacts)
	8 A (delayed contacts)
Inrush current, minimum	10 mA
Sq. Total current	55 A ² (observe derating)
Interrupting rating (ohmic load) max.	144 W (24 V DC, $\tau = 0$ ms)
	288 W (48 V DC, $\tau = 0$ ms)
	110 W (110 V DC, $\tau = 0$ ms, delayed contacts: 77 W)
	88 W (220 V DC, $\tau = 0$ ms)
	1500 VA (250 V AC, $\tau = 0$ ms, delayed contacts: 2000 VA)
	42 W (24 V DC, $\tau = 40$ ms, delayed contacts: 48 W)

PSR-SPP- 24DC/ESD/5X1/1X2/ T 2 - Safety relays



2981198

<https://www.phoenixcontact.com/us/products/2981198>

Maximum interrupting rating (inductive load)	42 W (48 V DC, $\tau = 40$ ms, delayed contacts: 40 W)
	42 W (110 V DC, $\tau = 40$ ms, delayed contacts: 35 W)
	42 W (220 V DC, $\tau = 40$ ms, delayed contacts: 33 W)
Switching power min.	50 mW
Switching capacity (360/h cycles)	4 A (24 V DC)
	4 A (230 V AC)
Switching capacity (3600/h cycles)	2.5 A (24 V (DC13))
	3 A (230 V (AC15))
Output fuse	10 A gL/gG (N/O contact)
	6 A gL/gG (N/C contact)

Connection data

Connection technology

pluggable	yes
-----------	-----

Conductor connection

Connection method	Push-in connection
Conductor cross-section, rigid	0.2 mm ² ... 1.5 mm ²
Conductor cross-section, flexible	0.2 mm ² ... 1.5 mm ²
Conductor cross-section, flexible, with ferrule, with plastic sleeve	only together with CRIMPFOX 6
Conductor cross-section AWG	24 ... 16
Stripping length	8 mm

Dimensions

Width	45 mm
Height	112 mm
Depth	114.5 mm

Material specifications

Color	yellow
Housing material	PBT

Characteristics

Safety data

Stop category (EN 60204-1)	0 (Undelayed contacts)
	1 (delayed contacts)

Safety data: EN ISO 13849

Performance level (PL)	e (for delayed contacts PL d)
------------------------	-------------------------------

Safety data: IEC 61508 - High demand

Safety Integrity Level (SIL)	3 (for delayed contacts SIL 2)
------------------------------	--------------------------------

Safety data: IEC 61508 - Low demand

Safety Integrity Level (SIL)	3 (for delayed contacts SIL 2)
------------------------------	--------------------------------

PSR-SPP- 24DC/ESD/5X1/1X2/ T 2 - Safety relays



2981198

<https://www.phoenixcontact.com/us/products/2981198>

Safety data: EN IEC 62061

Safety Integrity Level (SIL)	3 (for delayed contacts SIL 2)
------------------------------	--------------------------------

Environmental and real-life conditions

Ambient conditions

Degree of protection	IP20
Min. degree of protection of inst. location	IP54
Ambient temperature (operation)	-20 °C ... 55 °C (observe derating)
Ambient temperature (storage/transport)	-40 °C ... 70 °C
Maximum altitude	≤ 2000 m (Above sea level)
Max. permissible humidity (storage/transport)	75 % (on average, 85% infrequently, non-condensing)
Max. permissible relative humidity (operation)	75 % (on average, 85% infrequently, non-condensing)
Shock	15g
Vibration (operation)	10 Hz ... 150 Hz, 2g

Approvals

CE

Certificate	CE-compliant
-------------	--------------

Standards and regulations

Air clearances and creepage distances between the power circuits

Standards/regulations	DIN EN 50178/VDE 0160
-----------------------	-----------------------

Mounting

Mounting type	DIN rail mounting
Mounting position	any

PSR-SPP- 24DC/ESD/5X1/1X2/ T 2 - Safety relays



2981198

<https://www.phoenixcontact.com/us/products/2981198>

Drawings

Circuit diagram

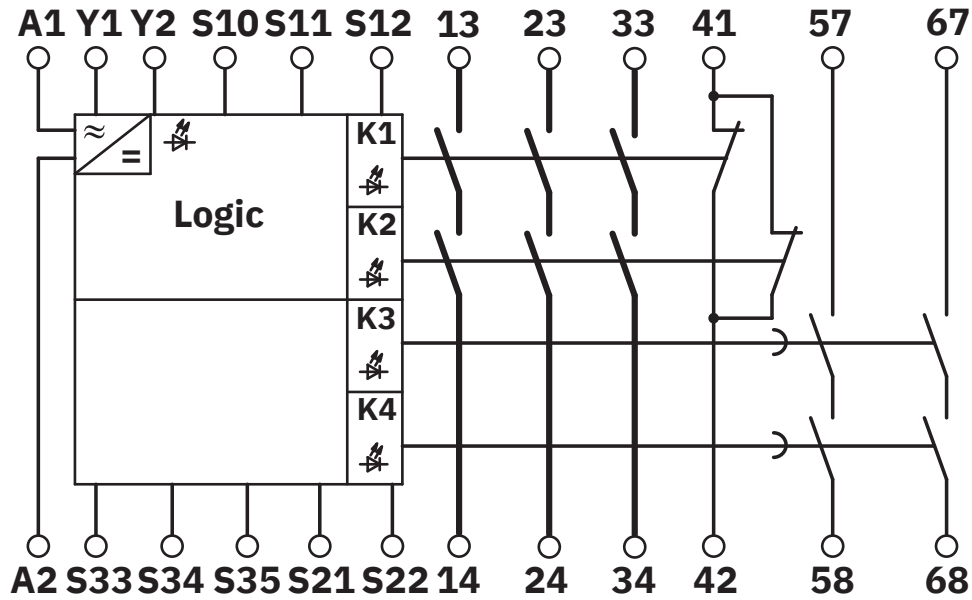

PSR-SPP- 24DC/ESD/5X1/1X2/ T 2 - Safety relays



2981198

<https://www.phoenixcontact.com/us/products/2981198>

Classifications

ECLASS

ECLASS-13.0	27371819
ECLASS-15.0	27371819

UNSPSC

UNSPSC 21.0	39122205
-------------	----------

PSR-SPP- 24DC/ESD/5X1/1X2/ T 2 - Safety relays



2981198

<https://www.phoenixcontact.com/us/products/2981198>

Environmental product compliance

China RoHS

Environment friendly use period (EFUP)	EFUP-E
	No hazardous substances above the limits

EU REACH SVHC

REACH candidate substance (CAS No.)	No substance above 0.1 wt%
-------------------------------------	----------------------------

Phoenix Contact 2026 © - all rights reserved
<https://www.phoenixcontact.com>

Phoenix Contact USA
586 Fulling Mill Road
Middletown, PA 17057, United States
(+717) 944-1300
info@phoenixcon.com