

PLC-SC-S/L - Switch

2980775

<https://www.phoenixcontact.com/us/products/2980775>



Please be informed that the data shown in this PDF document is generated from our online catalog. Please find the complete data in the user documentation. Our general terms of use for downloads are valid.



PLC-RELAY with integrated switch (actuation: Screwdriver) with screw connection, for mounting on DIN rail NS 35/7.5, input voltage ≤ 72 V DC

Your advantages

- Just 6.2 mm wide
- Floating confirmation contact
- Screw- and Push-in connection

Commercial data

Item number	2980775
Packing unit	1 pc
Note	Made to order (non-returnable)
Sales key	C461
Product key	DK621H
GTIN	4046356051507
Weight per piece (including packing)	33.42 g
Weight per piece (excluding packing)	28.45 g
Customs tariff number	85364190
Country of origin	DE

PLC-SC-S/L - Switch

2980775

<https://www.phoenixcontact.com/us/products/2980775>



Technical data

Product properties

Product type	Switch module
Product family	PLC-INTERFACE
Operating mode	100% operating factor

Insulation characteristics

Insulation	Basic insulation
Overvoltage category	III
Pollution degree	2

Data management status

Date of last data management	01.04.2026
------------------------------	------------

Electrical properties

Rated insulation voltage	85 V AC
Rated surge voltage	0.5 kV

Output data

Switching

Maximum switching voltage	72 V DC
Minimum switching voltage	2 V DC
Maximum inrush current	50 mA
Min. switching current	1 mA
Switching cycles, max.	100 (At 72 V DC / 50 mA) 10000 (at 12 V DC / 100 mA)
Insulation resistance	100 MΩ

Connection data

Connection method	Screw connection
Stripping length	8 mm
Screw thread	M3
Conductor cross-section rigid	0.14 mm ² ... 2.5 mm ²
Conductor cross-section flexible	0.14 mm ² ... 2.5 mm ² 0.2 mm ² ... 2.5 mm ² (Single ferrule) 2x 0.5 mm ² ... 1.5 mm ² (TWIN ferrule)
Conductor cross-section AWG	26 ... 14
Tightening torque	0.6 Nm ... 0.8 Nm

Dimensions

Width	6.2 mm
Height	80 mm
Depth	86 mm

PLC-SC-S/L - Switch

2980775

<https://www.phoenixcontact.com/us/products/2980775>



Material specifications

Color	green (RAL 6021)
Flammability rating according to UL 94 (Housing)	V0 (Housing)

Environmental and real-life conditions

Ambient conditions

Ambient temperature (operation)	-20 °C ... 60 °C
Ambient temperature (storage/transport)	-40 °C ... 70 °C

Standards and regulations

Standards/regulations	IEC 60664
	EN 50178

Mounting

Mounting type	DIN rail mounting
Assembly note	in rows with zero spacing
Mounting position	any

PLC-SC-S/L - Switch

2980775

<https://www.phoenixcontact.com/us/products/2980775>



Drawings

Application drawing

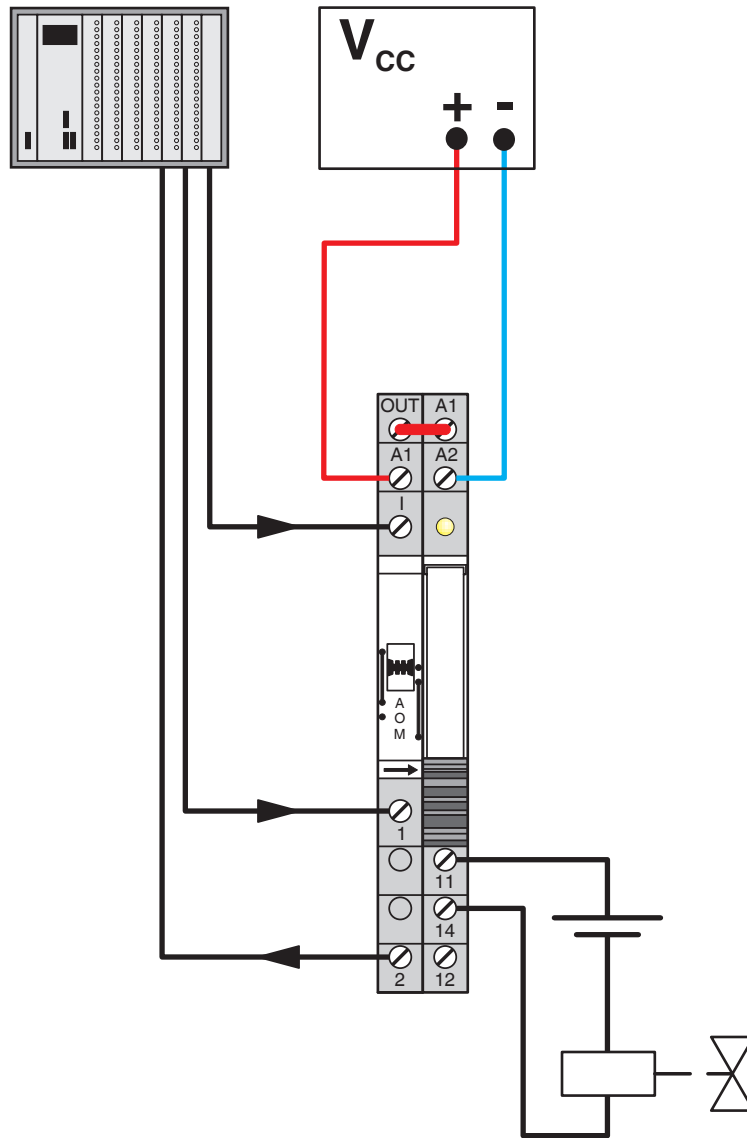

PLC-SC-S/L - Switch

2980775

<https://www.phoenixcontact.com/us/products/2980775>



Application drawing

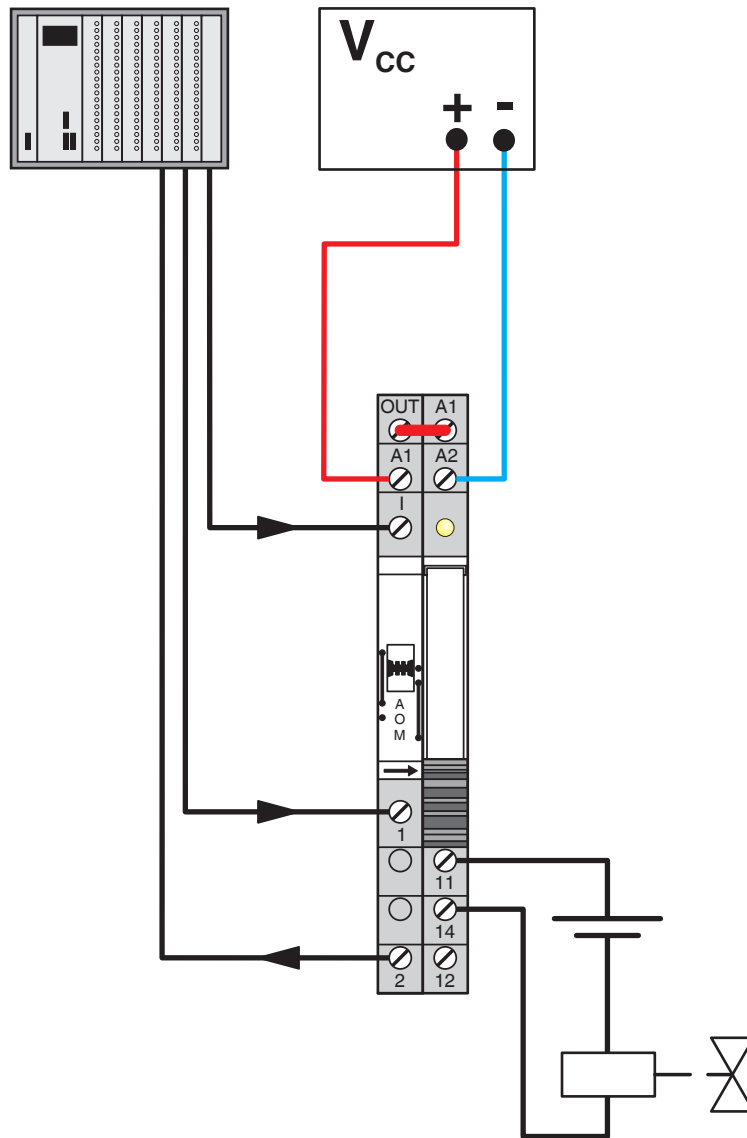

PLC-SC-S/L - Switch

2980775

<https://www.phoenixcontact.com/us/products/2980775>

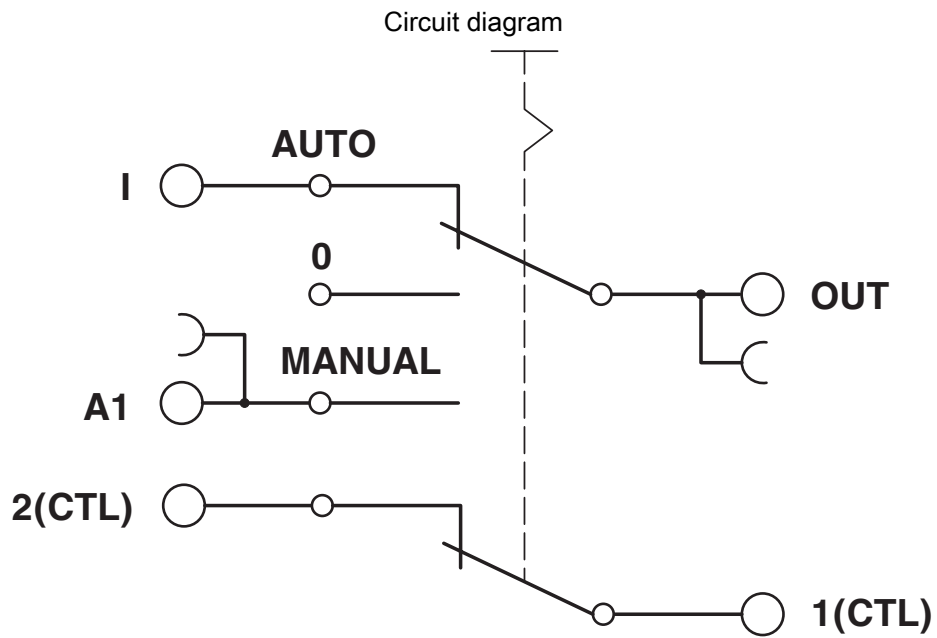

PLC-SC-S/L - Switch



2980775

<https://www.phoenixcontact.com/us/products/2980775>

Environmental product compliance

China RoHS

Environment friendly use period (EFUP)	EFUP-50
	An article-related China RoHS declaration table can be found in the download area for the respective article under "Manufacturer declaration". For all articles with EFUP-E, no China RoHS declaration table issued and required.

EU REACH SVHC

REACH candidate substance (CAS No.)	No substance above 0.1 wt%
-------------------------------------	----------------------------

Phoenix Contact 2026 © - all rights reserved
<https://www.phoenixcontact.com>

Phoenix Contact USA
586 Fulling Mill Road
Middletown, PA 17057, United States
(+717) 944-1300
info@phoenixcon.com