

DEK-TR/INV - Switching amplifier



2964319

<https://www.phoenixcontact.com/us/products/2964319>

Please be informed that the data shown in this PDF document is generated from our online catalog. Please find the complete data in the user documentation. Our general terms of use for downloads are valid.

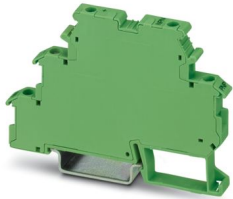

Inverter module. The inverter module inverts the signals of ground switching n-p-n transistor outputs into plus switching p-n-p outputs, and vice versa.

Your advantages

- The DEK-TR/INV inverter module inverts the signals of ground switching NPN transistor outputs into positive switching PNP outputs and vice versa

Commercial data

Item number	2964319
Packing unit	10 pc
Minimum order quantity	1 pc
Sales key	C460
Product key	DK61A3
GTIN	4017918176068
Weight per piece (including packing)	20.15 g
Weight per piece (excluding packing)	19.9 g
Customs tariff number	85365019
Country of origin	CN

Technical data

Notes

Note on application	Use of EB 80-DIK... bridges in the DEK terminal blocks: Absorption of humidity from the ambient air as well as an unfavorable tolerance between a larger number of DEK terminal blocks and the EB 80-DIK... bridge may cause (minor) expansion of the DEK housing. When the EB 80-DIK... bridges are used, therefore, it is recommended that these be disconnected after about 10 to 12 DEK terminal blocks and a wire bridge to the next DEK terminal block be inserted in their place.
---------------------	---

Product properties

Product type	Solid-state relay module
Product family	DEK
Application	Inverter module

Insulation characteristics

Overvoltage category	II
Pollution degree	2

Electrical properties

Maximum power dissipation for nominal condition	4.8 W
---	-------

Supply

Supply voltage range	20 V DC ... 30 V DC
----------------------	---------------------

Input data

Typical input current at U_N	200 mA
Transmission frequency	15 kHz

NPN

Switching threshold "1" signal voltage	< 5 V (at $U_V = 24$ V; < ($U_V - 19$ V))
Switching threshold "0" signal, voltage	> 15 V (at $U_V = 24$ V; > ($U_V - 9$ V))
Min. voltage input signal	-2 V
Max. voltage input signal	26 V (at $U_V = 24$ V; $U_V + 2$ V)

PNP

Switching threshold "1" signal voltage	> 19 V
Switching threshold "0" signal, voltage	< 9 V
Min. voltage input signal	-2 V
Max. voltage input signal	26 V (at $U_V = 24$ V; $U_V + 2$ V)

Output data

Continuous load current	200 mA
Leakage current	< 1 mA
Residual voltage	< 1 V
Transmission frequency	15 kHz

DEK-TR/INV - Switching amplifier



2964319

<https://www.phoenixcontact.com/us/products/2964319>

Contact switching type	1 N/O contact
Output nominal voltage	max. \pm 26 V

Connection data

Connection method	Screw connection
Stripping length	8 mm
Screw thread	M3
Conductor cross-section rigid	0.2 mm ² ... 4 mm ²
Conductor cross-section flexible	0.2 mm ² ... 2.5 mm ²
Conductor cross-section AWG	24 ... 12
Tightening torque	0.4 Nm ... 0.5 Nm

Dimensions

Width	6.2 mm
Height	80 mm
Depth	56 mm

Material specifications

Color	green (RAL 6021)
Housing material	Polyamide PA non-reinforced

Environmental and real-life conditions

Ambient conditions

Ambient temperature (operation)	-20 °C ... 50 °C
Ambient temperature (storage/transport)	-20 °C ... 70 °C

Standards and regulations

Standards/regulations	IEC 60947-5-1
-----------------------	---------------

Mounting

Mounting type	DIN rail mounting
Assembly note	in rows with zero spacing
Mounting position	any

DEK-TR/INV - Switching amplifier

2964319

<https://www.phoenixcontact.com/us/products/2964319>

Drawings

Application drawing

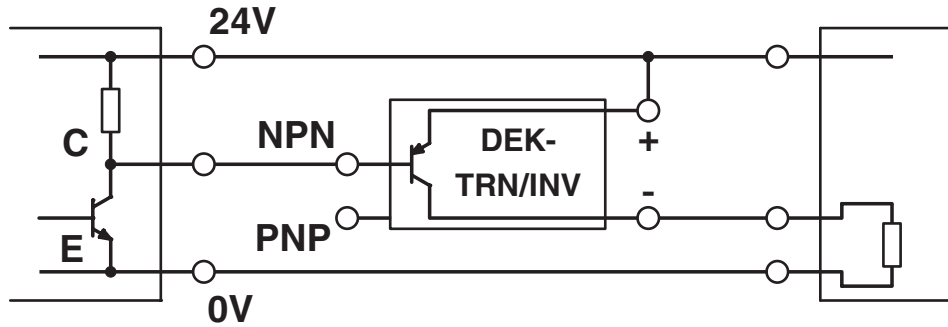

a = NPN output
b = load

Application drawing

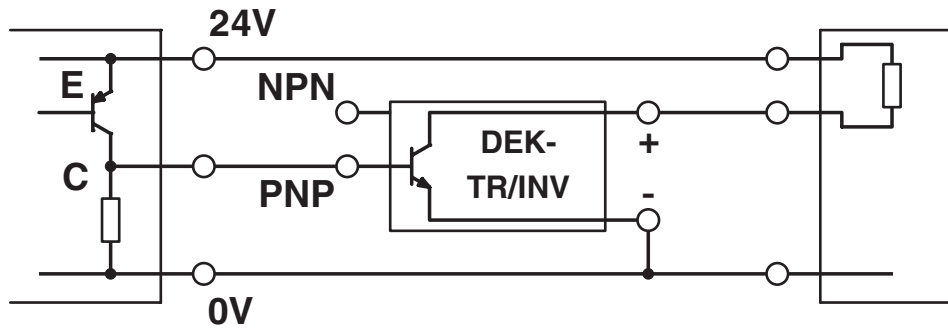

Circuit diagram

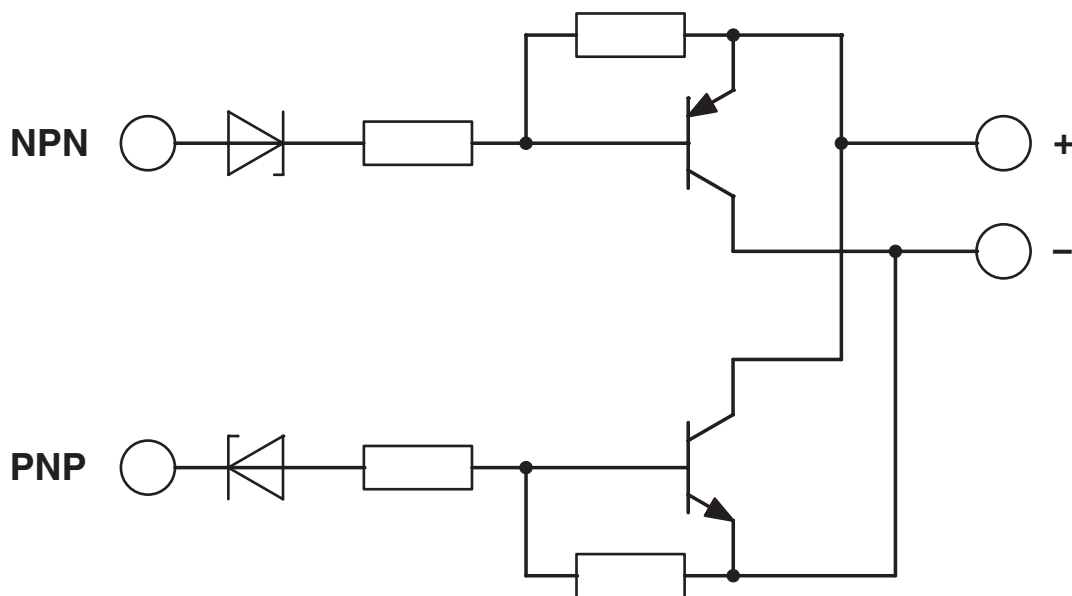

DEK-TR/INV - Switching amplifier



2964319

<https://www.phoenixcontact.com/us/products/2964319>

Approvals

To download certificates, visit the product detail page: <https://www.phoenixcontact.com/us/products/2964319>



cUL Recognized
Approval ID: FILE E 238705



UL Recognized
Approval ID: FILE E 238705

DEK-TR/INV - Switching amplifier



2964319

<https://www.phoenixcontact.com/us/products/2964319>

Classifications

ECLASS

ECLASS-13.0	27371604
ECLASS-15.0	27371604

ETIM

ETIM 10.0	EC001504
-----------	----------

UNSPSC

UNSPSC 21.0	39122300
-------------	----------

DEK-TR/INV - Switching amplifier



2964319

<https://www.phoenixcontact.com/us/products/2964319>

Environmental product compliance

EU RoHS

Fulfills EU RoHS substance requirements	Yes
Exemption	7(c)-I

China RoHS

Environment friendly use period (EFUP)	EFUP-50
	An article-related China RoHS declaration table can be found in the download area for the respective article under "Manufacturer declaration". For all articles with EFUP-E, no China RoHS declaration table issued and required.

EU REACH SVHC

REACH candidate substance (CAS No.)	No substance above 0.1 wt%
-------------------------------------	----------------------------

Phoenix Contact 2026 © - all rights reserved
<https://www.phoenixcontact.com>

Phoenix Contact USA
586 Fulling Mill Road
Middletown, PA 17057, United States
(+717) 944-1300
info@phoenixcon.com