

ELR W3/ 9-500 MM - Reversing load relay



2963543

<https://www.phoenixcontact.com/us/products/2963543>

Please be informed that the data shown in this PDF document is generated from our online catalog. Please find the complete data in the user documentation. Our general terms of use for downloads are valid.



Electronic reversing load relay with motor management, for direct driving of equipment in the 3-phase network, output: 110-550 V AC/3 x 8 A

Your advantages

- Optional connection to ELR-PB-GATEWAY
- Continuous status monitoring
- Special ELR-MM EX devices suitable for use in the chemical and petrochemical industries. A corresponding Ex-type examination certificate has been issued.
- Real power consumed calculated every 6.6 ms
- Freely parameterizable signaling and switching thresholds for underload/overload detection
- Display of apparent, real, and reactive power, currents, voltages, phase angle, cycle counter, and operating hours counter
- Switching of actuating/variable-speed drives, pumps, and tools with function, dirt or wear monitoring

Commercial data

Item number	2963543
Packing unit	1 pc
Note	Made to order (non-returnable)
Sales key	NULL
Product key	DK7222
GTIN	4017918899691
Weight per piece (including packing)	868.5 g
Weight per piece (excluding packing)	742.72 g
Customs tariff number	85364900
Country of origin	DE

ELR W3/ 9-500 MM - Reversing load relay



2963543

<https://www.phoenixcontact.com/us/products/2963543>

Technical data

Product properties

Product type	Electronic motor manager
Operating mode	100% operating factor

Electrical properties

Number of phases	3
Mains type	3-phase
Test voltage input/output	2.5 kV
Reversing frequency	≤ 2.5 Hz (at $\cos \varphi = 0.5$)

Supply

Input name	Device supply
Nominal supply voltage	24 V DC
Supply voltage range with reference to U_{VN}	0.8 ... 1.2
Quiescent current	80 mA AC
Protective circuit	Reverse polarity protection; Series polarity protection diode Surge protection
Operating voltage display	Green LED
Error indication	Red LED
Status display	LED (yellow)

Input data

Control

Input name	Control input right/left
Nominal input voltage U_N	24 V DC
Input voltage range in reference to U_N	0.8 ... 1.2 0.8 ... 1.2
Typical input current at U_N	7 mA
Reaction time in normal load operation	< 35 ms
Typical response time	< 25 ms
Typical turn-off time	< 25 ms
Reaction time in normal load operation	< 35 ms
Switch-over frequency	< 2.5 Hz (at $\cos \varphi = 0.5$)

Current measurement

Basic accuracy	$\pm 2\%$ (Of end value, typ. $\pm 1\%$)
Current range	0.25 A ... 8 A
Measuring via	Current transformer for any conductor current

Output data

AC output

ELR W3/ 9-500 MM - Reversing load relay



2963543

<https://www.phoenixcontact.com/us/products/2963543>

Nominal output voltage	500 V AC
Nominal output voltage range	110 V AC ... 550 V AC
Peak offstate voltage	1500 V
Mains frequency	50 Hz 60 Hz
Load current range	150 mA ... 8 A (see to derating)
Leakage current	typ. 7 mA
Residual voltage	typ. 1.4 V
Surge current	360 A (tp = 10 ms, at 25 °C)
Max. load value	645 A ² s
Protective circuit	RC element; RC element Surge protection
Surge voltage protection	> 880 V

Acknowledging contacts O1-O4

Number of outputs	4
Nominal output voltage	$U_{VN} - 1 V$
Continuous load current	max. 50 mA

Connection data

Control circuits

Connection method	Screw connection
Stripping length	8 mm
Screw thread	M3
Conductor cross-section rigid	0.2 mm ² ... 6 mm ²
Conductor cross-section flexible	0.2 mm ² ... 4 mm ²
Conductor cross-section AWG	24 ... 10

Load circuit

Connection method	Screw connection
Stripping length	8 mm
Screw thread	M3
Conductor cross-section rigid	0.2 mm ² ... 6 mm ²
Conductor cross-section flexible	0.2 mm ² ... 4 mm ²
Conductor cross-section AWG	24 ... 10

Interfaces

Data

Interface	RS-232
Transmission speed	4800 bit

Dimensions

Width	62 mm
Height	94 mm

ELR W3/ 9-500 MM - Reversing load relay



2963543

<https://www.phoenixcontact.com/us/products/2963543>

Depth	122 mm
-------	--------

Material specifications

Color	green (RAL 6021)
-------	------------------

Environmental and real-life conditions

Ambient conditions

Degree of protection	IP20
Ambient temperature (operation)	-20 °C ... 60 °C
Ambient temperature (storage/transport)	-20 °C ... 70 °C

Standards and regulations

Air clearances and creepage distances between the power circuits

Standards/regulations	DIN EN 50178
	safe isolation

Power station requirements

Standards/regulations	DWR 1300/ZXX01/DD/7080.8d
-----------------------	---------------------------

EMC regulations

Standards/regulations	EN 61000-6-2
	EN 61000-6-4

Mounting

Assembly note	can be aligned with spacing > 20 mm
Mounting position	Vertical (horizontal DIN rail)

ELR W3/ 9-500 MM - Reversing load relay



2963543

<https://www.phoenixcontact.com/us/products/2963543>

Drawings

Diagram

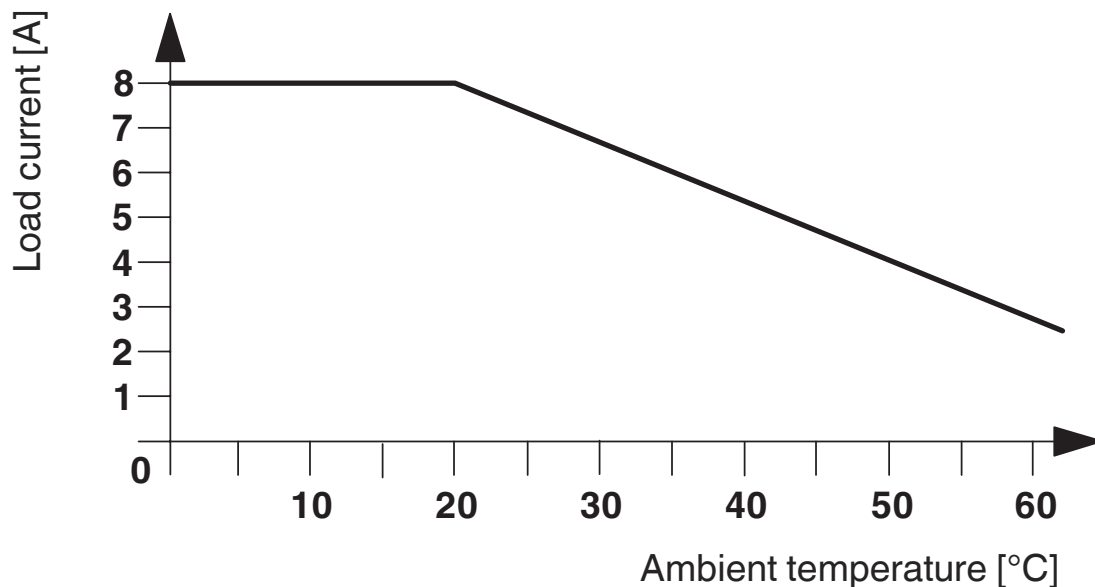

Block diagram

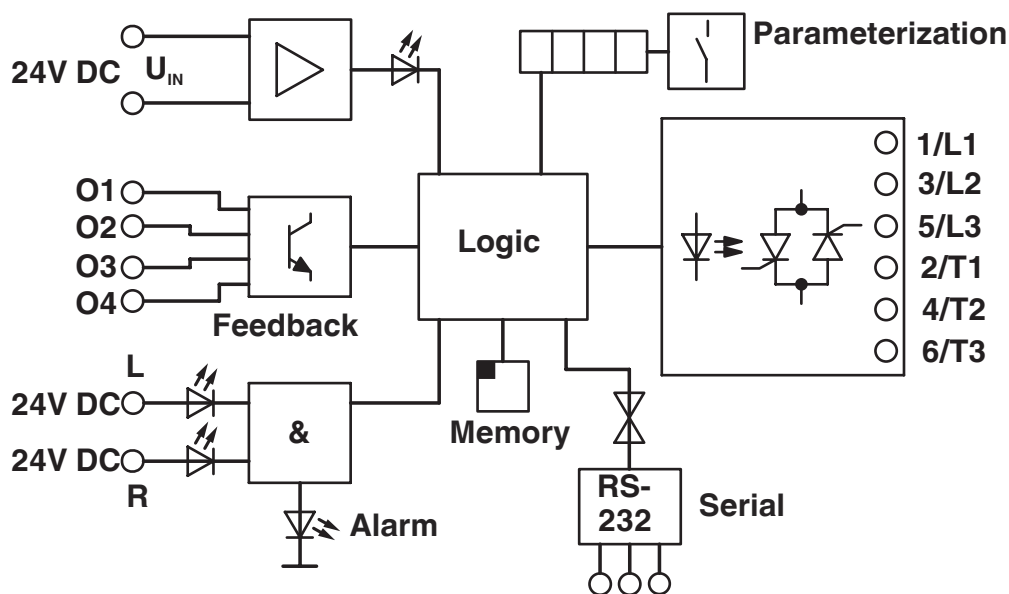

ELR W3/ 9-500 MM - Reversing load relay



2963543

<https://www.phoenixcontact.com/us/products/2963543>

Environmental product compliance

China RoHS

Environment friendly use period (EFUP)	EFUP-50
	An article-related China RoHS declaration table can be found in the download area for the respective article under "Manufacturer declaration". For all articles with EFUP-E, no China RoHS declaration table issued and required.

EU REACH SVHC

REACH candidate substance (CAS No.)	No substance above 0.1 wt%
-------------------------------------	----------------------------

Phoenix Contact 2026 © - all rights reserved
<https://www.phoenixcontact.com>

Phoenix Contact USA
586 Fulling Mill Road
Middletown, PA 17057, United States
(+717) 944-1300
info@phoenixcon.com