

UM 45-SEK - Lateral element

2959311

<https://www.phoenixcontact.com/us/products/2959311>

Please be informed that the data shown in this PDF document is generated from our online catalog. Please find the complete data in the user documentation. Our general terms of use for downloads are valid.



The figure shows version UM 25-SEK

Side element, with cable fixture, 6 mm wide, cables fixed with cable ties, these are not included in the scope of delivery.

Your advantages

- Flexible size and shape
- Fast mounting
- Inexpensive as a result of reducing the number of separate housing parts

Commercial data

Item number	2959311
Packing unit	10 pc
Minimum order quantity	1 pc
Sales key	AC13
Product key	ACHDBA
GTIN	4017918104443
Weight per piece (including packing)	4.99 g
Weight per piece (excluding packing)	4.99 g
Customs tariff number	39269097
Country of origin	PL

UM 45-SEK - Lateral element

2959311

<https://www.phoenixcontact.com/us/products/2959311>

Technical data

Product properties

Product type	Panel mounting base side part
Housing type	Press-drawn section housings
Housing series	UM
Product family	UM45
Ventilation openings present	no

Dimensions

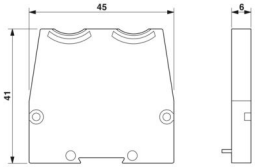
Dimensional drawing	
Depth	45 mm

Material specifications

Color (Side element)	green (RAL 6021)
Material Lateral element	PA
Flammability rating according to UL 94	V0

Environmental and real-life conditions

Ambient conditions

Ambient temperature (operation)	-40 °C ... 105 °C (depending on power dissipation)
---------------------------------	--

UM 45-SEK - Lateral element

2959311

<https://www.phoenixcontact.com/us/products/2959311>



Drawings

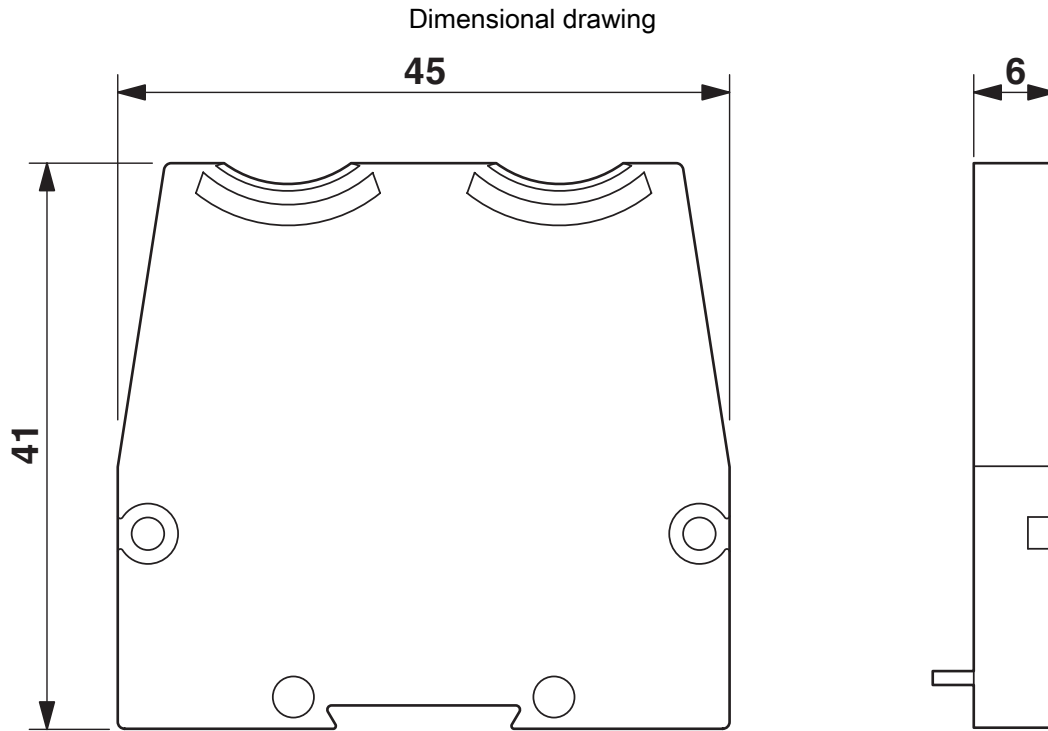

UM 45-SEK - Lateral element



2959311

<https://www.phoenixcontact.com/us/products/2959311>

Approvals

To download certificates, visit the product detail page: <https://www.phoenixcontact.com/us/products/2959311>



UL Recognized

Approval ID: E240868

UM 45-SEK - Lateral element



2959311

<https://www.phoenixcontact.com/us/products/2959311>

Classifications

ECLASS

ECLASS-13.0	27190602
ECLASS-15.0	27190602

ETIM

ETIM 10.0	EC002779
-----------	----------

UNSPSC

UNSPSC 21.0	31261500
-------------	----------

UM 45-SEK - Lateral element



2959311

<https://www.phoenixcontact.com/us/products/2959311>

Environmental product compliance

EU RoHS

Fulfills EU RoHS substance requirements	Yes, No exemptions
---	--------------------

China RoHS

Environment friendly use period (EFUP)	EFUP-E
	No hazardous substances above the limits

EU REACH SVHC

REACH candidate substance (CAS No.)	No substance above 0.1 wt%
-------------------------------------	----------------------------

EF3.1 Climate Change

CO2e kg	0.125 kg CO2e
---------	---------------

Phoenix Contact 2026 © - all rights reserved
<https://www.phoenixcontact.com>

Phoenix Contact USA
586 Fulling Mill Road
Middletown, PA 17057, United States
(+717) 944-1300
info@phoenixcon.com