

# EMG 45-SI6S/K - Fuse block

2955810

<https://www.phoenixcontact.com/us/products/2955810>



Please be informed that the data shown in this PDF document is generated from our online catalog. Please find the complete data in the user documentation. Our general terms of use for downloads are valid.



Fuse module with indicating pin, for 6 cartridge fuse inserts, 5 x 25 mm, common connection point

The figure shows version EMG 45-SI/K, with 6 cartridge fuse holders

## Commercial data

Item number	2955810
Packing unit	1 pc
Note	Made to order (non-returnable)
Sales key	NULL
Product key	CL132Z
GTIN	4017918085698
Weight per piece (including packing)	131.17 g
Weight per piece (excluding packing)	131.17 g
Customs tariff number	85363010
Country of origin	DE

# EMG 45-SI6S/K - Fuse block



2955810

<https://www.phoenixcontact.com/us/products/2955810>

## Technical data

### Product properties

Product type	Fuse module
--------------	-------------

### Insulation characteristics

Overvoltage category	III
Pollution degree	2

### Electrical properties

Nominal voltage $U_N$	250 V AC
-----------------------	----------

### Connection data

Connection method	Screw connection
Stripping length	8 mm
Screw thread	M3
Conductor cross-section rigid	0.2 mm <sup>2</sup> ... 4 mm <sup>2</sup>
Conductor cross-section flexible	0.2 mm <sup>2</sup> ... 2.5 mm <sup>2</sup>
Conductor cross-section AWG	24 ... 12

### Dimensions

Width	45 mm
Depth	67 mm

### Material specifications

Color	green (RAL 6021)
Housing insulation material	Polycarbonate fiber reinforced PC-F

### Environmental and real-life conditions

#### Ambient conditions

Ambient temperature (operation)	-20 °C ... 50 °C
Ambient temperature (storage/transport)	-20 °C ... 50 °C

### Standards and regulations

Standards/regulations	IEC 664
	IEC 664 A
	DIN VDE 0110-1
	DIN VDE 0160
	DIN VDE 0109-11, draft

### Mounting

Assembly note	in rows with zero spacing
Mounting position	any

# EMG 45-SI6S/K - Fuse block

2955810

<https://www.phoenixcontact.com/us/products/2955810>

## Drawings

Circuit diagram

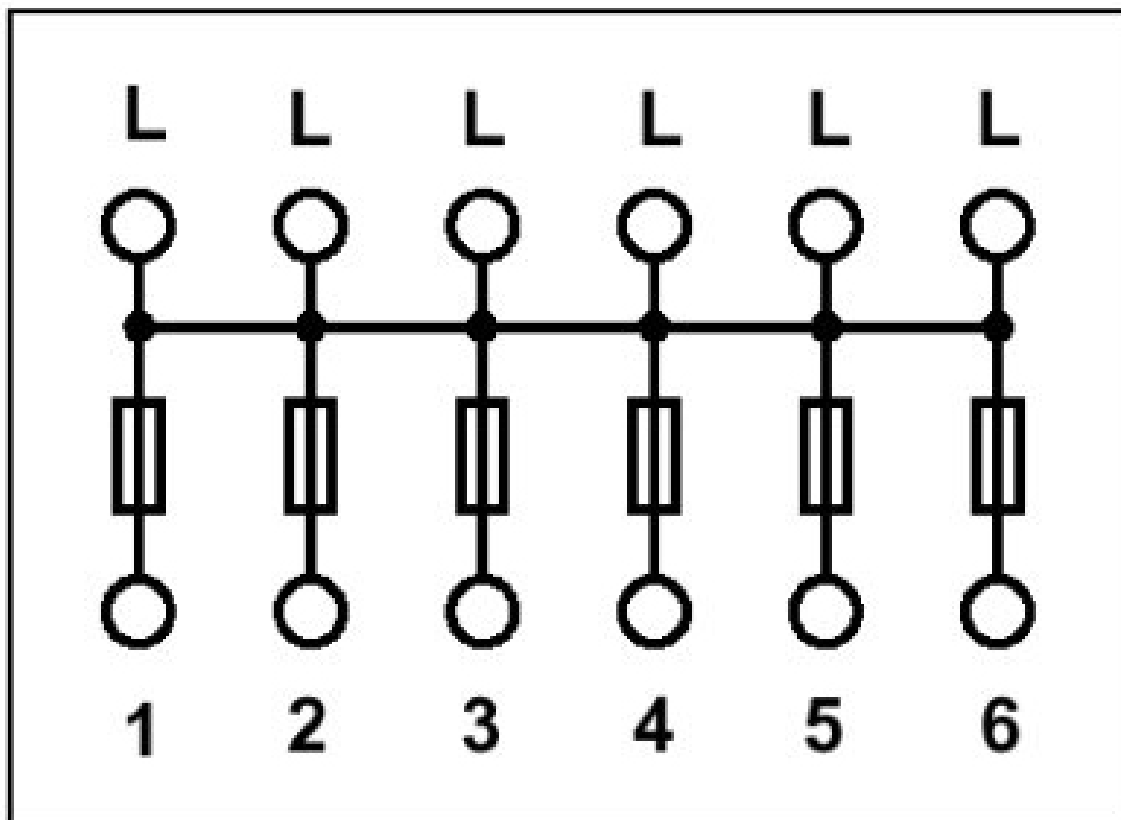

# EMG 45-SI6S/K

# EMG 45-SI6S/K - Fuse block

2955810

<https://www.phoenixcontact.com/us/products/2955810>



## Environmental product compliance

EU REACH SVHC

REACH candidate substance (CAS No.)	No substance above 0.1 wt%
-------------------------------------	----------------------------

Phoenix Contact 2026 © - all rights reserved

<https://www.phoenixcontact.com>

Phoenix Contact USA  
586 Fulling Mill Road  
Middletown, PA 17057, United States  
(+717) 944-1300  
[info@phoenixcon.com](mailto:info@phoenixcon.com)