

EMG 17-OV-220DC/240AC/3 - Solid-state relay module



2954264

<https://www.phoenixcontact.com/us/products/2954264>

Please be informed that the data shown in this PDF document is generated from our online catalog. Please find the complete data in the user documentation. Our general terms of use for downloads are valid.



Power solid-state relay, with LED and protective circuit in input and output circuits, input: 220 V DC, output: 48 - 280 V AC/max. 3 A

The figure shows version EMG 17-OV, with AC voltage output, max. 3 A

Commercial data

Item number	2954264
Packing unit	1 pc
Note	Made to order (non-returnable)
Sales key	NULL
Product key	DK61C3
GTIN	4017918084929
Weight per piece (including packing)	91.09 g
Weight per piece (excluding packing)	91.09 g
Customs tariff number	85364900
Country of origin	DE

EMG 17-OV-220DC/240AC/3 - Solid-state relay module



2954264

<https://www.phoenixcontact.com/us/products/2954264>

Technical data

Product properties

Product type	Solid-state relay module
Application	Output function
Operating mode	100% operating factor

Insulation characteristics

Insulation	Basic insulation
Overvoltage category	III
Pollution degree	2

Data management status

Date of last data management	01.04.2026
------------------------------	------------

Electrical properties

Test voltage (Input/output)	3.5 kV AC (Input/output)
-----------------------------	--------------------------

Input data

Nominal input voltage U_N	220 V DC
Input voltage range in reference to U_N	0.8 ... 1.2
Input voltage range	176 V DC ... 264 V DC
Switching threshold "0" signal in reference to U_N	≤ 0.4
Switching threshold "1" signal in reference to U_N	≥ 0.8
Typical input current at U_N	4.7 mA
Typical response time	10 ms
Typical turn-off time	10 ms
Operating voltage display	Yellow LED
Protective circuit	Reverse polarity protection; Polarity protection diode Surge protection; Varistor
Transmission frequency	25 Hz

Output data

Design of digital output	electronic
Output nominal voltage	240 V AC
Output voltage range	48 V AC ... 280 V AC (50 Hz ... 60 Hz)
Limiting continuous current	3 A (see derating curve)
Min. load current	50 mA
Leakage current	4 mA (in off state)
Surge current	160 A (t = 10 ms)
Phase angle $\cos \phi$ min	0.5
Max. load value	128 A ² s ($I^2 \times t$ where t = 10 ms)
Peak offstate voltage	600 V (Periodic peak reverse voltage)
Voltage drop at max. limiting continuous current	≤ 1 V

EMG 17-OV-220DC/240AC/3 - Solid-state relay module



2954264

<https://www.phoenixcontact.com/us/products/2954264>

Output circuit	2-conductor, floating
Protective circuit	RC element; RC element
	Surge protection; Varistor

Connection data

Input side

Connection method	Screw connection
Stripping length	8 mm
Screw thread	M3
Conductor cross-section rigid	0.2 mm ² ... 4 mm ²
Conductor cross-section flexible	0.2 mm ² ... 2.5 mm ²
Conductor cross-section AWG	24 ... 12

Output side

Connection method	Screw connection
Stripping length	8 mm
Screw thread	M3
Conductor cross-section rigid	0.2 mm ² ... 4 mm ²
Conductor cross-section flexible	0.2 mm ² ... 2.5 mm ²
Conductor cross-section AWG	24 ... 12

Dimensions

Width	17.5 mm
Height	75 mm
Depth	102 mm

Material specifications

Color	green (RAL 6021)
Flammability rating according to UL 94	V0

Environmental and real-life conditions

Ambient conditions

Degree of protection	IP20
Ambient temperature (operation)	-20 °C ... 60 °C
Ambient temperature (storage/transport)	-20 °C ... 70 °C

Standards and regulations

Standards/regulations	IEC 60664
	EN 50178

Mounting

Assembly note	in rows with zero spacing
Mounting position	horizontal

EMG 17-OV-220DC/240AC/3 - Solid-state relay module

2954264

<https://www.phoenixcontact.com/us/products/2954264>

Drawings

Diagram



- ① In rows with zero spacing
- ② stand-alone device

EMG 17-OV-220DC/240AC/3 - Solid-state relay module

2954264

<https://www.phoenixcontact.com/us/products/2954264>

Circuit diagram

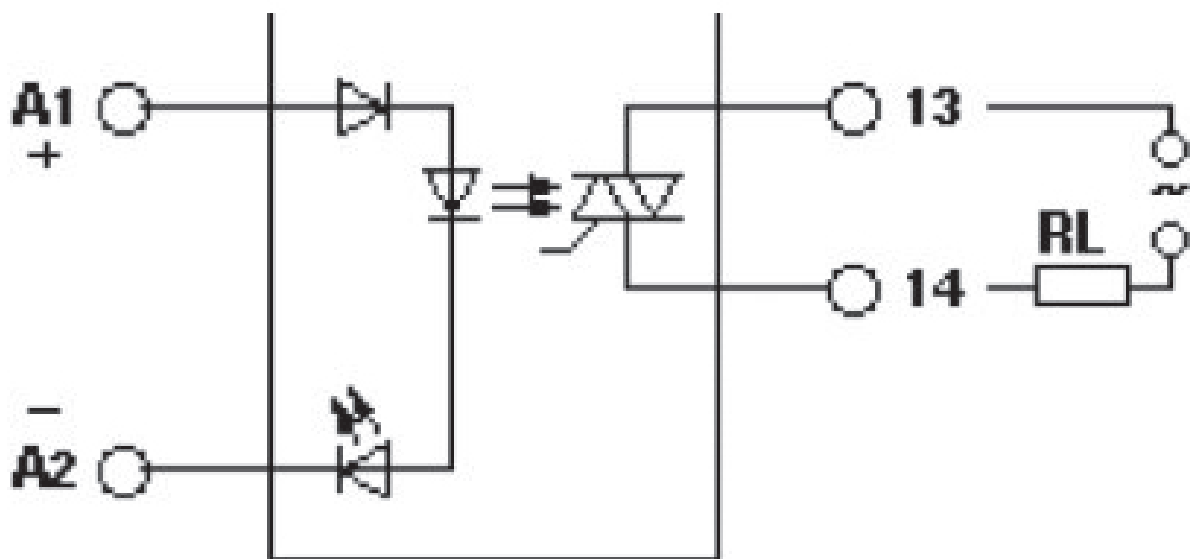

EMG 17-OV-220DC/240AC/3 - Solid-state relay module



2954264

<https://www.phoenixcontact.com/us/products/2954264>

Circuit diagram

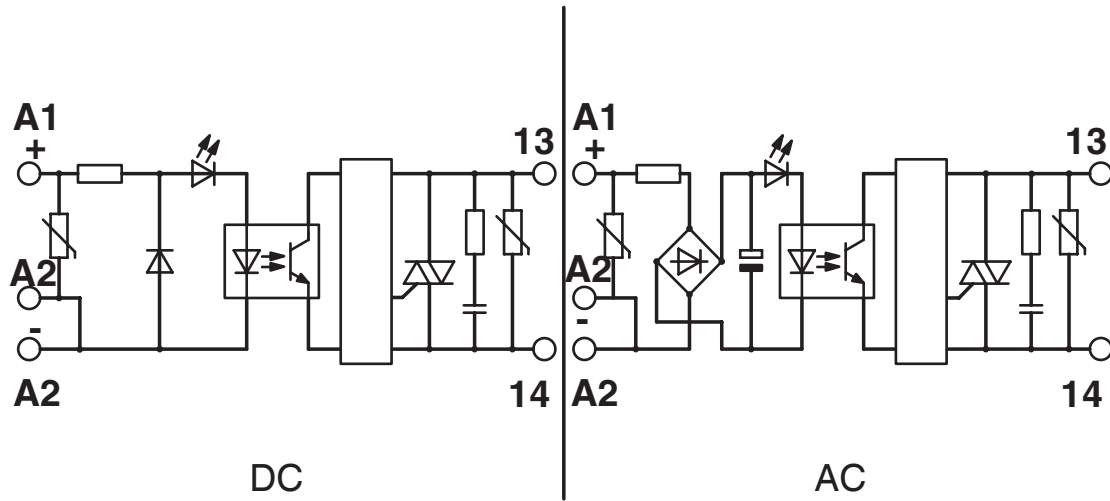

EMG 17-OV-220DC/240AC/3 - Solid-state relay module



2954264

<https://www.phoenixcontact.com/us/products/2954264>

Environmental product compliance

China RoHS

Environment friendly use period (EFUP)	EFUP-50
	An article-related China RoHS declaration table can be found in the download area for the respective article under "Manufacturer declaration". For all articles with EFUP-E, no China RoHS declaration table issued and required.

EU REACH SVHC

REACH candidate substance (CAS No.)	No substance above 0.1 wt%
-------------------------------------	----------------------------

Phoenix Contact 2026 © - all rights reserved
<https://www.phoenixcontact.com>

Phoenix Contact USA
586 Fulling Mill Road
Middletown, PA 17057, United States
(+717) 944-1300
info@phoenixcon.com