

# EMG 17-REL/SG-B 60/21/M - Relay module



2953948

<https://www.phoenixcontact.com/us/products/2953948>

Please be informed that the data shown in this PDF document is generated from our online catalog. Please find the complete data in the user documentation. Our general terms of use for downloads are valid.



Relay module, with soldered-in remanence miniature switching relay, with negative switching diode wiring, contacts (AgAu): small to large loads, 1 changeover contact, input voltage 60 V DC

The figure shows version EMG 17-REL, with soldered-in Latching miniature switching relay

## Commercial data

Item number	2953948
Packing unit	1 pc
Note	Made to order (non-returnable)
Sales key	C460
Product key	DK6142
GTIN	4017918084684
Weight per piece (including packing)	52.8 g
Weight per piece (excluding packing)	52.8 g
Customs tariff number	85364190
Country of origin	DE

# EMG 17-REL/SG-B 60/21/M - Relay module



2953948

<https://www.phoenixcontact.com/us/products/2953948>

## Technical data

### Product properties

Product type	Relay Module
Application	Universal
Operating mode	100% operating factor (observe max. input pulse length)
Mechanical service life	approx. $3 \times 10^7$ cycles

### Insulation characteristics

Overvoltage category	III
Pollution degree	2

### Data management status

Date of last data management	12.09.2025
------------------------------	------------

### Electrical properties

Maximum power dissipation for nominal condition	1.68 W
Test voltage (Winding/contact)	4 kV AC (50 Hz, 1 min., winding/contact)

### Input data

#### Coil side

Nominal input voltage $U_N$	60 V DC
Input voltage range	48 V DC ... 66 V DC
Input voltage range in reference to $U_N$	0.8 ... 1.1
Typical input current at $U_N$	28 mA
Typical response time	10 ms
Typical release time	10 ms
Pulse time range	30 ms ... 5 s
Protective circuit	Freewheeling diode; Freewheeling diode Reverse polarity protection; Polarity protection diode

### Output data

#### Switching

Contact switching type	Single contact, 1 changeover contact
Type of switch contact	Single contact
Contact material	AgAu
Maximum switching voltage	24 V AC/DC
Limiting continuous current	0.5 A
Maximum inrush current	0.2 A
Interrupting rating (ohmic load) max.	5 W (at 24 V DC) 5 VA (for 24 V AC)

#### Switching: when the gold layer is destroyed

Maximum switching voltage	250 V AC/DC
---------------------------	-------------

# EMG 17-REL/SG-B 60/21/M - Relay module



2953948

<https://www.phoenixcontact.com/us/products/2953948>

Limiting continuous current	5 A
Maximum inrush current	6 A
Interrupting rating (ohmic load) max.	120 W (at 24 V DC)
	40 W (at 48 V DC)
	35 MW (at 60 V DC)
	30 W (at 110 V DC)
	55 W (at 220 V DC)
	1250 VA (for 250 V AC)

## Connection data

### Coil side

Connection method	Screw connection
Stripping length	8 mm
Screw thread	M3
Conductor cross-section rigid	0.2 mm <sup>2</sup> ... 4 mm <sup>2</sup>
Conductor cross-section flexible	0.2 mm <sup>2</sup> ... 2.5 mm <sup>2</sup>
Conductor cross-section AWG	24 ... 12

### Contact side

Connection method	Screw connection
Stripping length	8 mm
Screw thread	M3
Conductor cross-section rigid	0.2 mm <sup>2</sup> ... 4 mm <sup>2</sup>
Conductor cross-section flexible	0.2 mm <sup>2</sup> ... 2.5 mm <sup>2</sup>
Conductor cross-section AWG	24 ... 12

## Dimensions

Width	17.5 mm
Height	75 mm
Depth	62.5 mm

## Material specifications

Color	green (RAL 6021)
-------	------------------

## Environmental and real-life conditions

### Ambient conditions

Ambient temperature (operation)	-20 °C ... 50 °C
Ambient temperature (storage/transport)	-20 °C ... 70 °C

## Standards and regulations

Standards/regulations	IEC 60664
	EN 50178

## Mounting

# EMG 17-REL/SG-B 60/21/M - Relay module



2953948

<https://www.phoenixcontact.com/us/products/2953948>

Assembly note	in rows with zero spacing
Mounting position	any

# EMG 17-REL/SG-B 60/21/M - Relay module



2953948

<https://www.phoenixcontact.com/us/products/2953948>

## Drawings

Circuit diagram

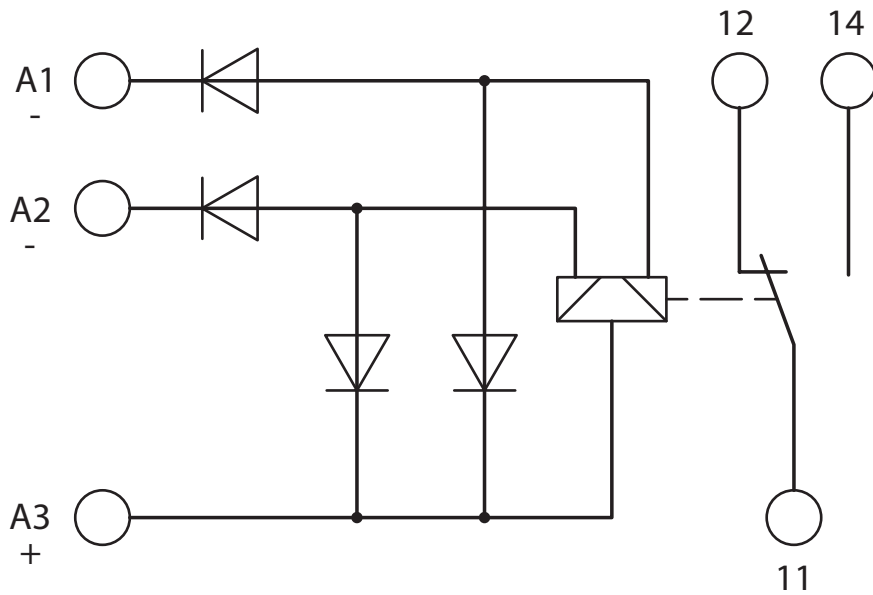

# EMG 17-REL/SG-B 60/21/M - Relay module



2953948

<https://www.phoenixcontact.com/us/products/2953948>

## Environmental product compliance

### China RoHS

Environment friendly use period (EFUP)	EFUP-50
	An article-related China RoHS declaration table can be found in the download area for the respective article under "Manufacturer declaration". For all articles with EFUP-E, no China RoHS declaration table issued and required.

### EU REACH SVHC

REACH candidate substance (CAS No.)	No substance above 0.1 wt%
-------------------------------------	----------------------------

Phoenix Contact 2026 © - all rights reserved  
<https://www.phoenixcontact.com>

Phoenix Contact USA  
586 Fulling Mill Road  
Middletown, PA 17057, United States  
(+717) 944-1300  
[info@phoenixcon.com](mailto:info@phoenixcon.com)