

EMG 22-LG - Electronics housing

2946133

<https://www.phoenixcontact.com/us/products/2946133>

Please be informed that the data shown in this PDF document is generated from our online catalog. Please find the complete data in the user documentation. Our general terms of use for downloads are valid.



Electronic housing, with universal foot, for PCB insertion, without screw connection terminal blocks and cover

Commercial data

Item number	2946133
Packing unit	10 pc
Minimum order quantity	10 pc
Sales key	AC11
Product key	ACHCBA
GTIN	4017918082093
Weight per piece (including packing)	21.61 g
Weight per piece (excluding packing)	21.61 g
Customs tariff number	84879090
Country of origin	DE

EMG 22-LG - Electronics housing

2946133

<https://www.phoenixcontact.com/us/products/2946133>

Technical data

Product properties

Product type	Complete housing
Housing type	Component housing
Housing type	Basic housing
Housing series	EMG
Product family	EMG
Type	Lower part of housing, removable cover optional
Number of positions	8
Pitch	5 mm
Set comprises	2942991 EMG 22-LG/SET
Ventilation openings present	no

Dimensions

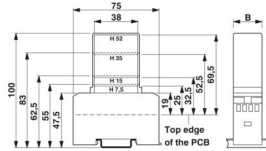
Dimensional drawing	
Width	22.5 mm
Installed height	47.5 mm
Height NS 35/7,5	55 mm 83 mm 100 mm
Depth	75 mm
Length	75 mm
Pitch	5 mm

Material specifications

Color (Housing)	green (RAL 6021)
Material Housing	PC (glass-fiber reinforced)
Flammability rating according to UL 94	V0

Environmental and real-life conditions

Ambient conditions

Ambient temperature (operation)	-40 °C ... 125 °C
---------------------------------	-------------------

Mounting

Mounting type	DIN rail mounting
---------------	-------------------

EMG 22-LG - Electronics housing

2946133

<https://www.phoenixcontact.com/us/products/2946133>



Drawings

Dimensional drawing

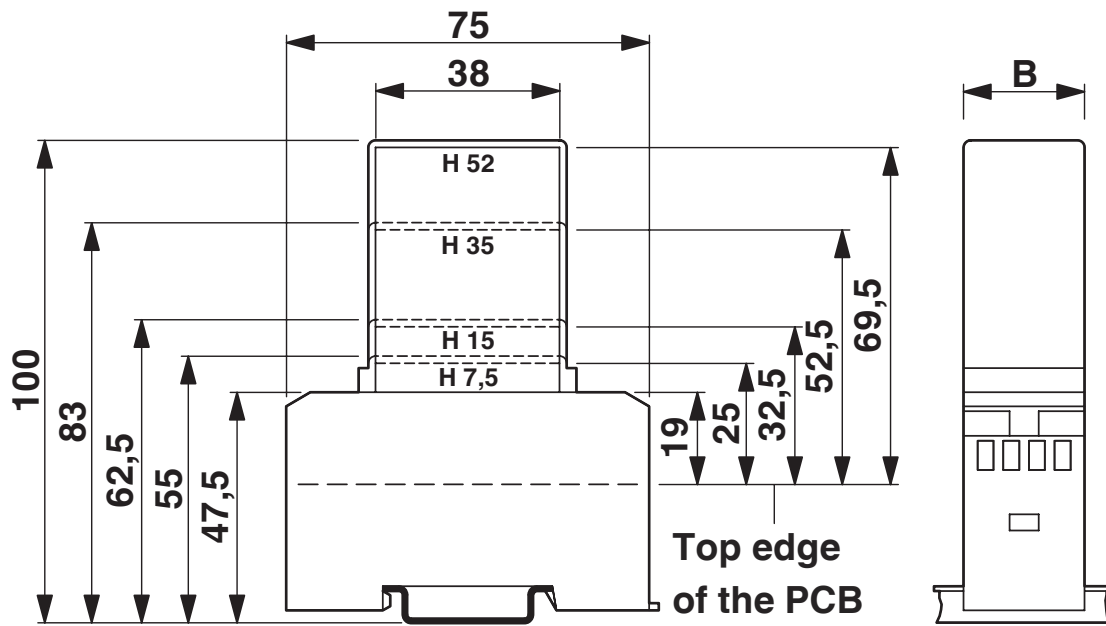

EMG 22-LG - Electronics housing

2946133

<https://www.phoenixcontact.com/us/products/2946133>

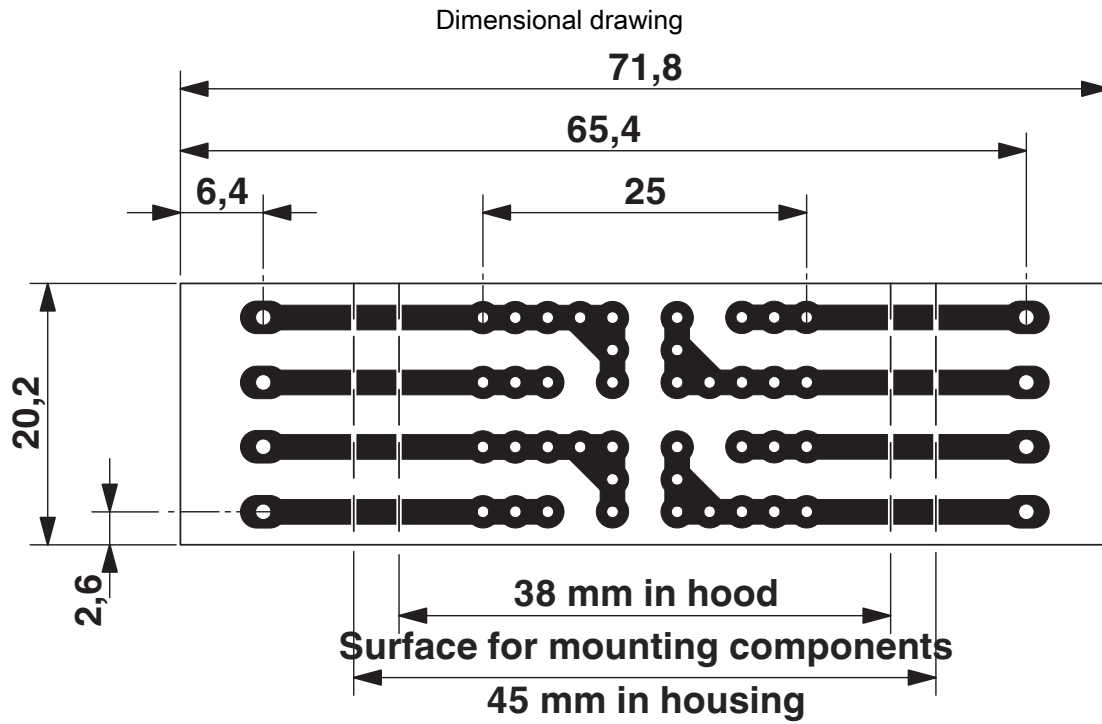

Pitch 5 mm

a = Area for mounting components, 38 mm in the hood

b = Area for mounting components, 45 mm in the housing

EMG 22-LG - Electronics housing

2946133

<https://www.phoenixcontact.com/us/products/2946133>



Classifications

ECLASS

ECLASS-13.0	27190101
ECLASS-15.0	27190101

ETIM

ETIM 10.0	EC001031
-----------	----------

UNSPSC

UNSPSC 21.0	31261500
-------------	----------

EMG 22-LG - Electronics housing



2946133

<https://www.phoenixcontact.com/us/products/2946133>

Environmental product compliance

EU RoHS

Fulfills EU RoHS substance requirements	Yes, No exemptions
---	--------------------

China RoHS

Environment friendly use period (EFUP)	EFUP-E
	No hazardous substances above the limits

EU REACH SVHC

REACH candidate substance (CAS No.)	No substance above 0.1 wt%
-------------------------------------	----------------------------

EF3.1 Climate Change

CO2e kg	0.15 kg CO2e
---------	--------------

Phoenix Contact 2026 © - all rights reserved
<https://www.phoenixcontact.com>

Phoenix Contact USA
586 Fulling Mill Road
Middletown, PA 17057, United States
(+717) 944-1300
info@phoenixcon.com