

EMG 17-LG-7,5 - Electronics housing



2944106

<https://www.phoenixcontact.com/us/products/2944106>

Please be informed that the data shown in this PDF document is generated from our online catalog. Please find the complete data in the user documentation. Our general terms of use for downloads are valid.



Electronic housing, with universal foot, for p.c.b. insertion, without screw connection terminal blocks and cover, pitch 7.5

Commercial data

Item number	2944106
Packing unit	10 pc
Minimum order quantity	1 pc
Note	Made to order (non-returnable)
Product key	ACHCBA
GTIN	4017918081430
Weight per piece (including packing)	19.5 g
Weight per piece (excluding packing)	19.5 g
Country of origin	DE

EMG 17-LG-7,5 - Electronics housing



2944106

<https://www.phoenixcontact.com/us/products/2944106>

Technical data

Product properties

Product type	Complete housing
Housing type	Component housing
Product family	EMG...-LG
Type	Lower part of housing, removable cover optional
Number of positions	4
Pitch	7.5 mm

Dimensions

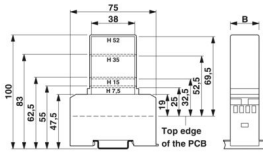
Dimensional drawing	
Width	17.5 mm
Installed height	47.5 mm
Height NS 35/7,5	47.5 mm
Depth	75 mm
Length	75 mm
Pitch	7.5 mm

Material specifications

Color	green
Flammability rating according to UL 94	V0
Housing material	Polycarbonate fiber reinforced

Environmental and real-life conditions

Ambient conditions

Ambient temperature (operation)	-40 °C ... 125 °C
---------------------------------	-------------------

Mounting

Mounting type	DIN rail mounting
---------------	-------------------

EMG 17-LG-7,5 - Electronics housing

2944106

<https://www.phoenixcontact.com/us/products/2944106>



Drawings

Dimensional drawing



1 = Top edge of the PCB

B = Housing width

EMG 17-LG-7,5 - Electronics housing

2944106

<https://www.phoenixcontact.com/us/products/2944106>

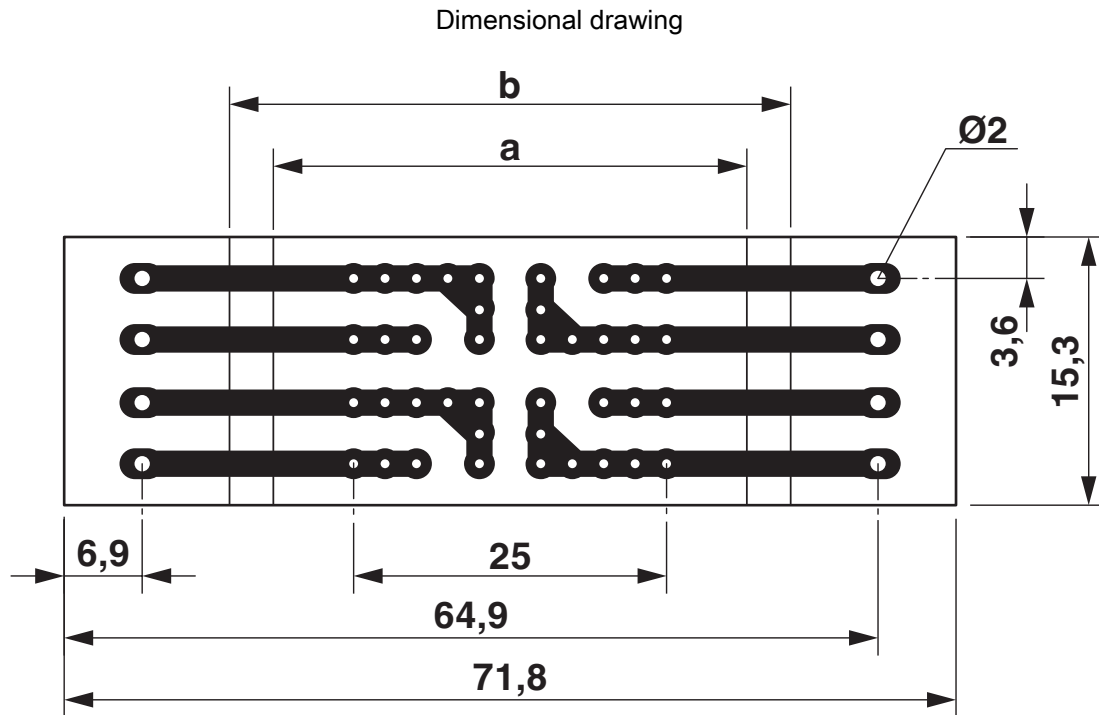

Pitch 7.5 mm

a = Area for mounting components, 38 mm in the hood

b = Area for mounting components, 45 mm in the housing

EMG 17-LG-7,5 - Electronics housing



2944106

<https://www.phoenixcontact.com/us/products/2944106>

Environmental product compliance

China RoHS

Environment friendly use period (EFUP)	EFUP-E
	No hazardous substances above the limits

EU REACH SVHC

REACH candidate substance (CAS No.)	No substance above 0.1 wt%
-------------------------------------	----------------------------

Phoenix Contact 2026 © - all rights reserved
<https://www.phoenixcontact.com>

Phoenix Contact USA
586 Fulling Mill Road
Middletown, PA 17057, United States
(+717) 944-1300
info@phoenixcon.com