

# CM 50-LG/H 12,5/BO BK - Electronics housing



2943592

<https://www.phoenixcontact.com/us/products/2943592>

Please be informed that the data shown in this PDF document is generated from our online catalog. Please find the complete data in the user documentation. Our general terms of use for downloads are valid.



DIN rail housing, Complete housing, with vents, width: 50 mm, height: 102 mm, depth: 115.5 mm, color: black (similar RAL 9005), cross connection: Not provided for

## Your advantages

- Robust housing technology
- Easy snap-on mounting on symmetrical DIN rails in accordance with EN 60715
- Touch-proof and contamination-proof accommodation of the electronics
- Flexible accommodation of different connection elements (from high-position connectors to electronic PCB terminal blocks)

## Commercial data

Item number	2943592
Packing unit	5 pc
Minimum order quantity	1 pc
Sales key	AC11
Product key	ACHCDA
GTIN	4017918081195
Weight per piece (including packing)	146.42 g
Weight per piece (excluding packing)	146.42 g
Customs tariff number	84879090
Country of origin	DE

2943592

<https://www.phoenixcontact.com/us/products/2943592>

## Technical data

### Product properties

Product type	Complete housing
Housing type	DIN rail housing
Housing series	CM
Product family	CM LG
Type	Housing closed, ventilation slots
Ventilation openings present	yes

### Dimensions

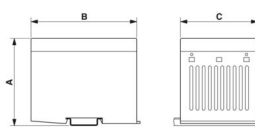
Dimensional drawing	
Width	50 mm
Height	102 mm
Depth	115.5 mm

### Material specifications

Color (Housing)	black (RAL 9005)
Material Housing	PC (glass-fiber reinforced)
Flammability rating according to UL 94	V0
Surface characteristics	untreated

### Environmental and real-life conditions

#### Ambient conditions

Ambient temperature (operation)	-40 °C ... 105 °C (depending on power dissipation)
---------------------------------	----------------------------------------------------

### Mounting

Mounting type	DIN rail mounting
---------------	-------------------

2943592

<https://www.phoenixcontact.com/us/products/2943592>

## Drawings

Dimensional drawing



Dimension A: 115.5 mm; dimension B: 102 mm; dimension C: 50 mm

Dimensional drawing

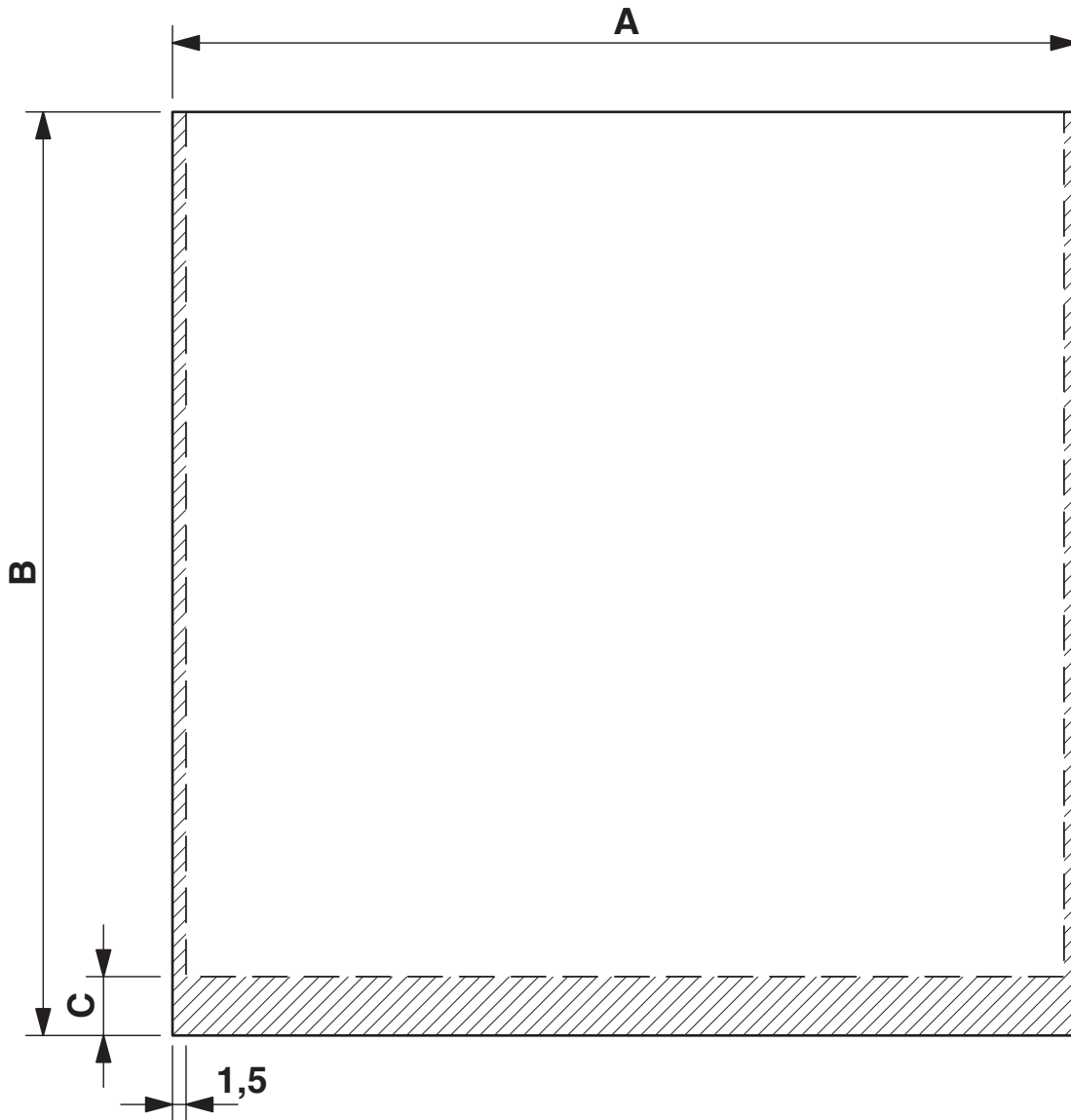

PCB 1, 7: Dimension A: 47.5 mm; B: 102.0 mm; C: 6.5 mm

PCB 8, 13: Dimension A: 100.0 mm; B: 102.0 mm; C: 6.5 mm

PCB 10: Dimension A: 100.0 mm; B: 92.3 mm; C: 0 mm

# CM 50-LG/H 12,5/BO BK - Electronics housing



2943592

<https://www.phoenixcontact.com/us/products/2943592>

Schematic diagram

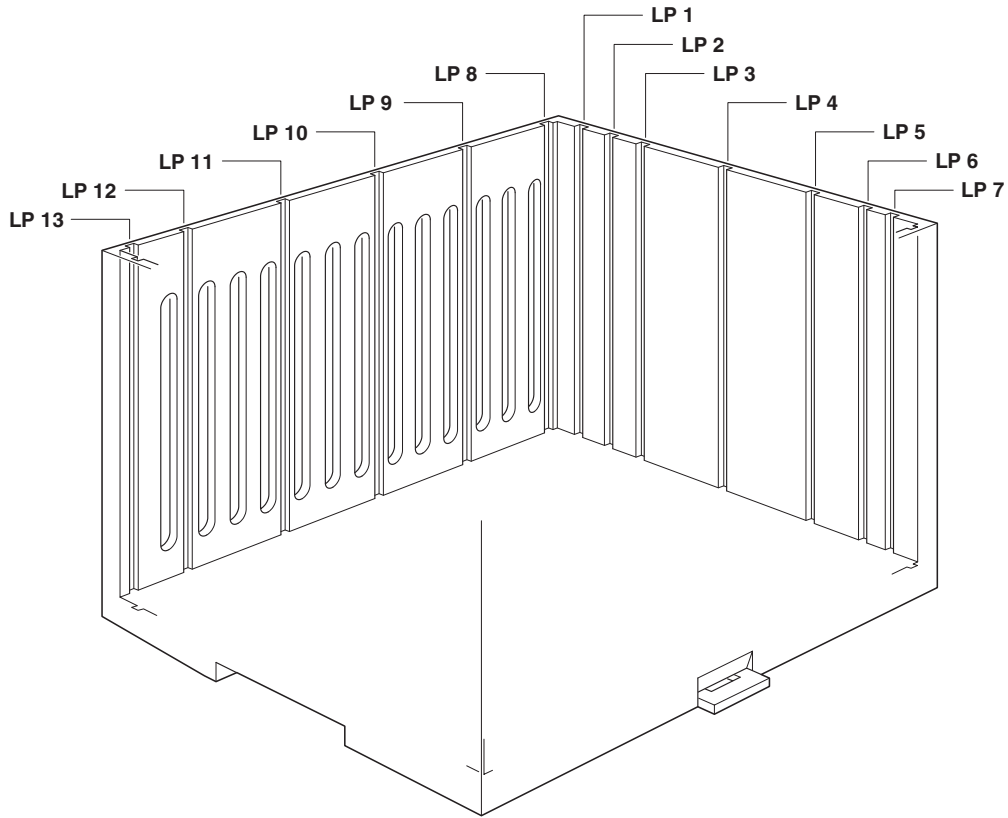

# CM 50-LG/H 12,5/BO BK - Electronics housing



2943592

<https://www.phoenixcontact.com/us/products/2943592>

## Classifications

### ECLASS

ECLASS-13.0	27190101
ECLASS-15.0	27190101

### ETIM

ETIM 10.0	EC001031
-----------	----------

### UNSPSC

UNSPSC 21.0	31261500
-------------	----------

# CM 50-LG/H 12,5/BO BK - Electronics housing



2943592

<https://www.phoenixcontact.com/us/products/2943592>

## Environmental product compliance

### EU RoHS

Fulfills EU RoHS substance requirements	Yes, No exemptions
-----------------------------------------	--------------------

### China RoHS

Environment friendly use period (EFUP)	EFUP-E
	No hazardous substances above the limits

### EU REACH SVHC

REACH candidate substance (CAS No.)	No substance above 0.1 wt%
-------------------------------------	----------------------------

Phoenix Contact 2026 © - all rights reserved  
<https://www.phoenixcontact.com>

Phoenix Contact USA  
586 Fulling Mill Road  
Middletown, PA 17057, United States  
(+717) 944-1300  
[info@phoenixcon.com](mailto:info@phoenixcon.com)