

# EMG100-LG/O GY - Electronics housing



2942289

<https://www.phoenixcontact.com/us/products/2942289>

Please be informed that the data shown in this PDF document is generated from our online catalog. Please find the complete data in the user documentation. Our general terms of use for downloads are valid.



Electronic housing, for PCB insertion, without screw connection terminal blocks and cover, with open terminal space

## Commercial data

|                                      |                                |
|--------------------------------------|--------------------------------|
| Item number                          | 2942289                        |
| Packing unit                         | 5 pc                           |
| Minimum order quantity               | 1 pc                           |
| Note                                 | Made to order (non-returnable) |
| Product key                          | ACHCBA                         |
| GTIN                                 | 4017918365295                  |
| Weight per piece (including packing) | 78.85 g                        |
| Weight per piece (excluding packing) | 78.85 g                        |
| Country of origin                    | DE                             |

2942289

<https://www.phoenixcontact.com/us/products/2942289>

## Technical data

### Product properties

|                     |   |
|---------------------|---|
| Housing type        | Component housing                               |
| Type                | Lower part of housing, removable cover optional |
| Number of positions | 38  |
| Pitch               | 5 mm  |

### Dimensions

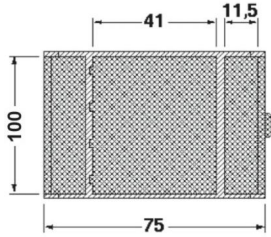
|                     |   |  |
|---------------------|---|--|
| Dimensional drawing |  |  |
| Width               | 100 mm  |  |
| Height NS 35/7,5    | 55 mm   |  |
|                     | 83 mm   |  |
|                     | 100 mm  |  |
| Depth               | 75 mm   |  |
| Length              | 75 mm   |  |
| Pitch               | 5 mm  |  |

### Material specifications

|  |                                |
|--|--------------------------------|
| Color                                  | light gray                     |
| Flammability rating according to UL 94 | V0                             |
| Housing material                       | Polycarbonate fiber reinforced |

### Environmental and real-life conditions

#### Ambient conditions

|                                 |                   |
|---------------------------------|-------------------|
| Ambient temperature (operation) | -40 °C ... 125 °C |
|---------------------------------|-------------------|

Drawings

Dimensional drawing

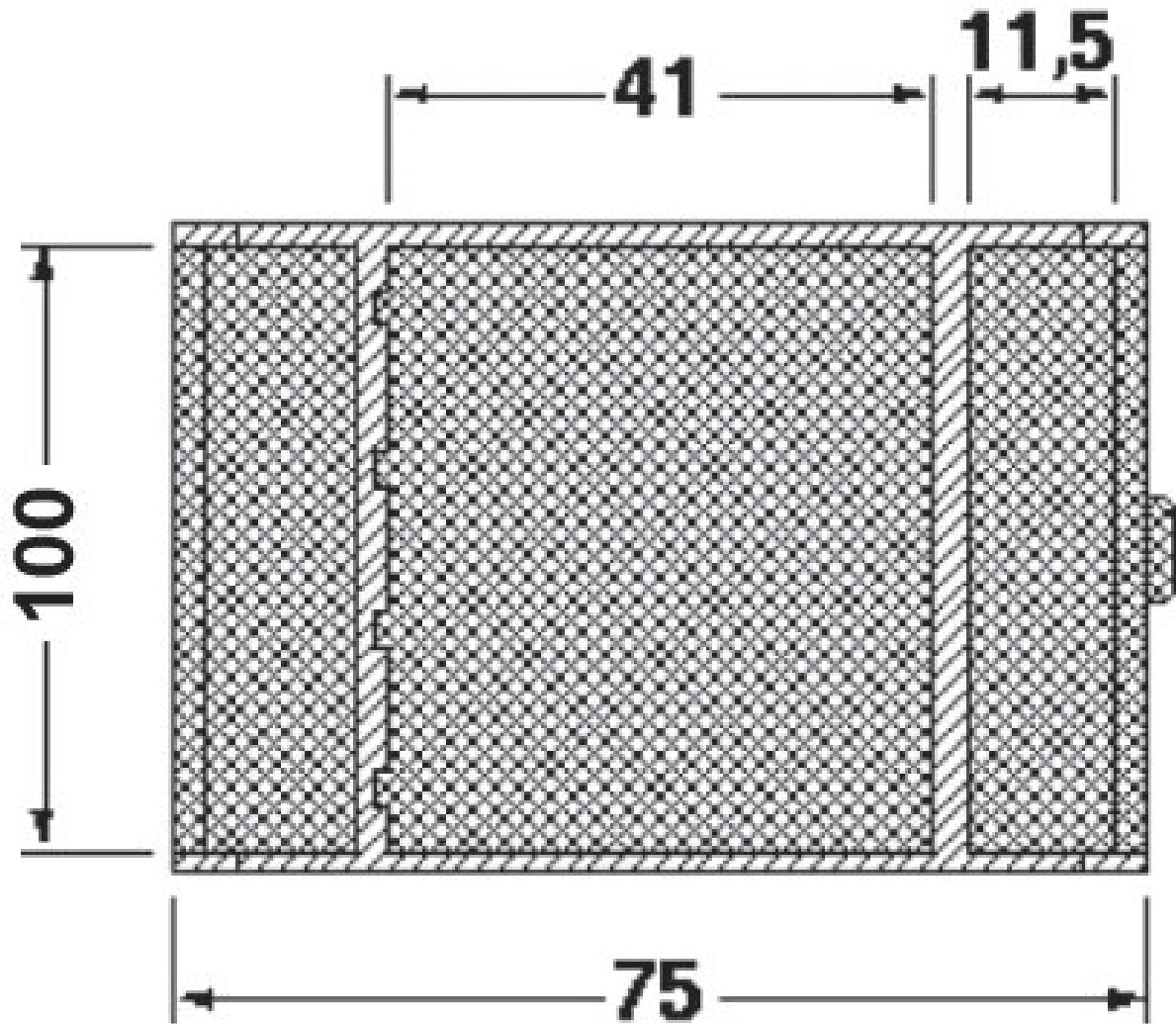

# EMG100-LG/O GY - Electronics housing

2942289

<https://www.phoenixcontact.com/us/products/2942289>



Dimensional drawing



1 = Top edge of the PCB

B = Housing width

# EMG100-LG/O GY - Electronics housing



2942289

<https://www.phoenixcontact.com/us/products/2942289>

## Environmental product compliance

### China RoHS

|  |  |
|--|--|
| Environment friendly use period (EFUP) | EFUP-E                                   |
|  | No hazardous substances above the limits |

### EU REACH SVHC

|                                     |                            |
|-------------------------------------|----------------------------|
| REACH candidate substance (CAS No.) | No substance above 0.1 wt% |
|-------------------------------------|----------------------------|

Phoenix Contact 2026 © - all rights reserved  
<https://www.phoenixcontact.com>

Phoenix Contact USA  
586 Fulling Mill Road  
Middletown, PA 17057, United States  
(+717) 944-1300  
[info@phoenixcon.com](mailto:info@phoenixcon.com)