

MS 9 - Load relay

2941895

<https://www.phoenixcontact.com/us/products/2941895>



Please be informed that the data shown in this PDF document is generated from our online catalog. Please find the complete data in the user documentation. Our general terms of use for downloads are valid.

Motor protection relay



The figure shows the version ELR W3/9-400/FLK/PLC-MS9

Commercial data

Item number	2941895
Packing unit	1 pc
Note	Made to order (non-returnable)
Sales key	C472
Product key	DK722Z
GTIN	4017918107710
Weight per piece (including packing)	120.6 g
Weight per piece (excluding packing)	88.68 g
Customs tariff number	85364900
Country of origin	DE

MS 9 - Load relay

2941895

<https://www.phoenixcontact.com/us/products/2941895>



Technical data

Product properties

Product type	Relay Module
--------------	--------------

Data management status

Date of last data management	12.09.2025
------------------------------	------------

MS 9 - Load relay

2941895

<https://www.phoenixcontact.com/us/products/2941895>



Drawings

Circuit diagram

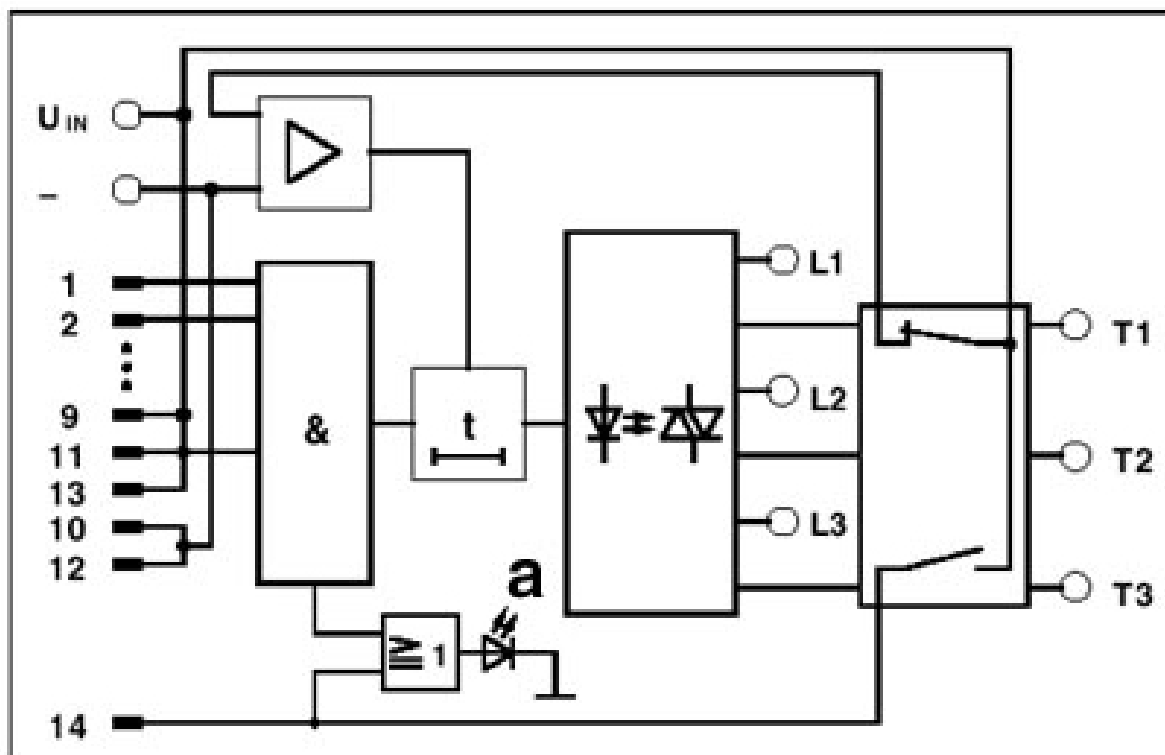

a = alarm

MS 9 - Load relay

2941895

<https://www.phoenixcontact.com/us/products/2941895>



Environmental product compliance

EU REACH SVHC

REACH candidate substance (CAS No.)	
-------------------------------------	--

	No substance above 0.1 wt%
--	----------------------------

Phoenix Contact 2026 © - all rights reserved

<https://www.phoenixcontact.com>

Phoenix Contact USA
586 Fulling Mill Road
Middletown, PA 17057, United States
(+717) 944-1300
info@phoenixcon.com