

# QUINT-PS-100-240AC/24DC/ 5 - Power supply



2938581

<https://www.phoenixcontact.com/us/products/2938581>

Please be informed that the data shown in this PDF document is generated from our online catalog. Please find the complete data in the user documentation. Our general terms of use for downloads are valid.



DIN rail power supply unit 24 V DC/5 A, primary-switched, 1-phase.  
Please use the following item in new systems: 2904600

## Product description

QUINT POWER power supply units for plant and special engineering reliably start heavy loads with high inrush currents using the POWER BOOST. Thanks to the wide-range input and extensive package of approvals, they can be used in all sectors of industry the world over. The switching output or floating relay contact are used for remote diagnostics.

## Commercial data

Item number	2938581
Packing unit	1 pc
Sales key	CM11
Product key	CMPP13
GTIN	4017918890520
Weight per piece (including packing)	1,172.6 g
Weight per piece (excluding packing)	830 g
Customs tariff number	85044030
Country of origin	TH

## Technical data

### Input data

#### AC operation

Nominal input voltage range	100 V AC ... 240 V AC
Input voltage range	85 V AC ... 264 V AC
	90 V DC ... 350 V DC
Input voltage range AC	85 V AC ... 264 V AC
Input voltage range DC	90 V DC ... 350 V DC
Voltage type of supply voltage	AC/DC
Inrush current	< 20 A (typical)
Inrush current integral ( $I^2t$ )	< 2.5 A <sup>2</sup> s
AC frequency range	45 Hz ... 65 Hz
Frequency range DC	0 Hz
Mains buffering time	> 30 ms (120 V AC)
	> 130 ms (230 V AC)
Current consumption	approx. 1.6 A (120 V AC)
	approx. 0.84 A (230 V AC)
Nominal power consumption	134 W
Protective circuit	Transient surge protection; Varistor
Typical response time	< 1 s
Input fuse	5 A (slow-blow, internal)
Permissible backup fuse	B6 B10 B16
Permissible DC backup fuse	DC: Connect a suitable fuse upstream
Recommended breaker for input protection	6 A ... 16 A (Characteristics B, C, D, K)

### Output data

Efficiency	> 89 %
Nominal output voltage	24 V DC $\pm$ 1 %
Setting range of the output voltage ( $U_{Set}$ )	22.5 V DC ... 28.5 V DC
Nominal output current ( $I_N$ )	5 A (up to 60 °C)
POWER BOOST ( $I_{Boost}$ )	7.5 A
Derating	60 °C ... 70 °C (2.5 %/K)
Feedback voltage resistance	35 V DC
Protection against overvoltage at the output (OVP)	$\leq$ 35 V DC
Max. capacitive load	unlimited
Active current limitation	Approx. $I_{BOOST} = 7.5$ A (for short-circuit)
Control deviation	< 1 % (change in load, static 10 % ... 90 %)
	< 2 % (change in load, dynamic 10 % ... 90 %)
	< 0.1 % (change in input voltage $\pm$ 10 %)
Residual ripple	< 10 mV <sub>PP</sub> (with nominal values)
Output power	120 W
Peak switching voltages nominal load	< 30 mV <sub>PP</sub> (20 MHz)

# QUINT-PS-100-240AC/24DC/ 5 - Power supply



2938581

<https://www.phoenixcontact.com/us/products/2938581>

Maximum no-load power dissipation	< 2 W
Power loss nominal load max.	< 14 W
Rise time	< 2 ms ( $U_{OUT}$ (10 % ... 90 %))
Connection in parallel	yes, for redundancy and increased capacity
Connection in series	yes

Signal: DC OK active

Output description	$U_{OUT} > 0.9 \times U_N$ : High signal
Maximum switching voltage	$\leq 24$ V
Output voltage	+ 24 V DC (Signal)
Maximum inrush current	$\leq 40$ mA
Continuous load current	$\leq 40$ mA

Signal: DC OK floating

Output description	Relay contact, $U_{OUT} > 0.9 \times U_N$ : Contact closed
Maximum switching voltage	$\leq 30$ V AC/DC
Maximum inrush current	$\leq 1$ A
Continuous load current	$\leq 1$ A

## Connection data

Input

Connection method	Pluggable screw connection
Conductor cross-section, rigid min.	0.2 mm <sup>2</sup>
Conductor cross-section, rigid max.	2.5 mm <sup>2</sup>
Conductor cross-section flexible min.	0.2 mm <sup>2</sup>
Conductor cross-section flexible max.	2.5 mm <sup>2</sup>
Conductor cross-section AWG min.	24
Conductor cross-section AWG max.	12
Stripping length	7 mm
Screw thread	M3
Tightening torque, min	0.5 Nm
Tightening torque max	0.6 Nm

Output

Connection method	Pluggable screw connection
Conductor cross-section, rigid min.	0.2 mm <sup>2</sup>
Conductor cross-section, rigid max.	2.5 mm <sup>2</sup>
Conductor cross-section flexible min.	0.2 mm <sup>2</sup>
Conductor cross-section flexible max.	2.5 mm <sup>2</sup>
Conductor cross-section AWG min.	24
Conductor cross-section AWG max.	12
Stripping length	7 mm
Screw thread	M3
Tightening torque, min	0.5 Nm
Tightening torque max	0.6 Nm

# QUINT-PS-100-240AC/24DC/ 5 - Power supply



2938581

<https://www.phoenixcontact.com/us/products/2938581>

## Signal

Conductor cross-section, rigid min.	0.2 mm <sup>2</sup>
Conductor cross-section, rigid max.	2.5 mm <sup>2</sup>
Conductor cross-section flexible min.	0.2 mm <sup>2</sup>
Conductor cross-section flexible max.	2.5 mm <sup>2</sup>
Conductor cross-section AWG min.	24
Conductor cross-section AWG max.	12
Screw thread	M3
Tightening torque, min	0.5 Nm
Tightening torque max	0.6 Nm

## Signaling

Types of signaling	LED
	Active switching output
	Relay contact
Operating voltage display	Green LED

### Signal output: DC OK active

Status display	"DC OK" LED green
Note on status display	$U_{OUT} < 0.9 \times U_N$ : LED flashing

### Signal output: DC OK floating

Status display	"DC OK" LED green
----------------	-------------------

## Electrical properties

Number of phases	1
Insulation voltage input/output	4 kV AC (type test)
	2 kV AC (routine test)
Insulation voltage output / PE	500 V DC (routine test)
Insulation voltage input / PE	3.5 kV AC (type test)
	2 kV AC (routine test)

## Product properties

Product type	Power supply
Product family	QUINT POWER
MTBF (IEC 61709, SN 29500)	> 500000 h

### Insulation characteristics

Protection class	I (with PE connection)
Degree of pollution	2

## Dimensions

Width	55 mm
Height	130 mm
Depth	125 mm

# QUINT-PS-100-240AC/24DC/ 5 - Power supply



2938581

<https://www.phoenixcontact.com/us/products/2938581>

## Alternative assembly

Width	122 mm
Height	130 mm
Depth	58 mm

## Mounting

Assembly note	alignable: horizontally 0 mm, vertically 50 mm
Mounting position	horizontal DIN rail NS 35, EN 60715

## Material specifications

Housing material	Metal
Type of housing	AluNox (AlMg1)

## Environmental and real-life conditions

### Ambient conditions

Degree of protection	IP20
Ambient temperature (operation)	-25 °C ... 70 °C (> 60 °C Derating: 2,5 %/K)
Ambient temperature (storage/transport)	-40 °C ... 85 °C
Max. permissible relative humidity (operation)	95 % (at 25 °C, non-condensing)
Shock	18 ms, 30g, in each space direction (according to IEC 60068-2-27)
Vibration (operation)	< 15 Hz, amplitude ±2.5 mm (according to IEC 60068-2-6) 15 Hz ... 150 Hz, 2.3g, 90 min.

## Standards and regulations

Standard – Limitation of mains harmonic currents	EN 61000-3-2
Standard - Electrical safety	EN 62368-1
Standard - Equipment safety	GS (tested safety)
Standard – Protection against shock currents, basic requirements for protective separation in electrical equipment	EN 62368-1
Standard – Safety extra-low voltage	EN 62368-1 (SELV) EN 60204 (PELV)
Standard - Safe isolation	DIN VDE 0100-410

## Approvals

Shipbuilding approval	DNV GL (EMC A)
UL approvals	UL/C-UL Recognized UL 60950-1 UL/C-UL listed UL 508 UL ANSI/ISA-12.12.01 Class I, Division 2, Groups A, B, C, D (Hazardous Location)

## EMC data

Electromagnetic compatibility	Conformance with EMC Directive 2014/30/EU
Low Voltage Directive	Conformance with Low Voltage Directive 2014/35/EC
EMC requirements for noise emission	EN 61000-6-3

# QUINT-PS-100-240AC/24DC/ 5 - Power supply



2938581

<https://www.phoenixcontact.com/us/products/2938581>

	EN 61000-6-4
EMC requirements for noise immunity	EN 61000-6-1
	EN 61000-6-2

## Noise emission

Standards/regulations	EN 55011 (EN 55022)
-----------------------	---------------------

## Electrostatic discharge

Standards/regulations	EN 61000-4-2
Housing	Level 4

## Electrostatic discharge

Contact discharge	8 kV
Discharge in air	15 kV
Comments	Criterion B

## Electromagnetic HF field

Standards/regulations	EN 61000-4-3
-----------------------	--------------

## Electromagnetic HF field

Frequency range	80 MHz ... 2 GHz
Test field strength	10 V/m
Comments	Criterion A

## Fast transients (burst)

Standards/regulations	EN 61000-4-4
-----------------------	--------------

## Fast transients (burst)

Input	4 kV (level 4 - asymmetrical)
Output	2 kV (Level 3 - asymmetrical)
Signal	1 kV (Level 2 - asymmetrical)

## Surge voltage load (surge)

Standards/regulations	EN 61000-4-5
-----------------------	--------------

## Surge voltage load (surge)

Input	4 kV (inst. class 4 - asymmetrical: conductor to ground)
	2 kV (inst. class 4 -symmetrical: conductor to conductor)
Output	0.5 kV (level 1 - asymmetrical: conductor to ground)
	0.5 kV (level 1 - symmetrical: conductor to conductor)
Signal	1 kV (level 2 - asymmetrical: conductor to ground)
Comments	Criterion B

## Conducted interference

Standards/regulations	EN 61000-4-6
-----------------------	--------------

## Conducted interference

Input/output/signal	Level 3 - asymmetrical
Frequency range	0.15 MHz ... 80 MHz

# QUINT-PS-100-240AC/24DC/ 5 - Power supply



2938581

<https://www.phoenixcontact.com/us/products/2938581>

Comments	Criterion A
Voltage	10 V

## Voltage dips

Standards/regulations	EN 61000-4-11
-----------------------	---------------

## Emitted interference

Standards/regulations	EN 61000-6-3
Radio interference voltage in acc. with EN 55011	EN 55011 (EN 55022) Class B, area of application: Industry and residential
Emitted radio interference in acc. with EN 55011	EN 55011 (EN 55022) Class B, area of application: Industry and residential

# QUINT-PS-100-240AC/24DC/ 5 - Power supply



2938581

<https://www.phoenixcontact.com/us/products/2938581>

## Drawings

Block diagram

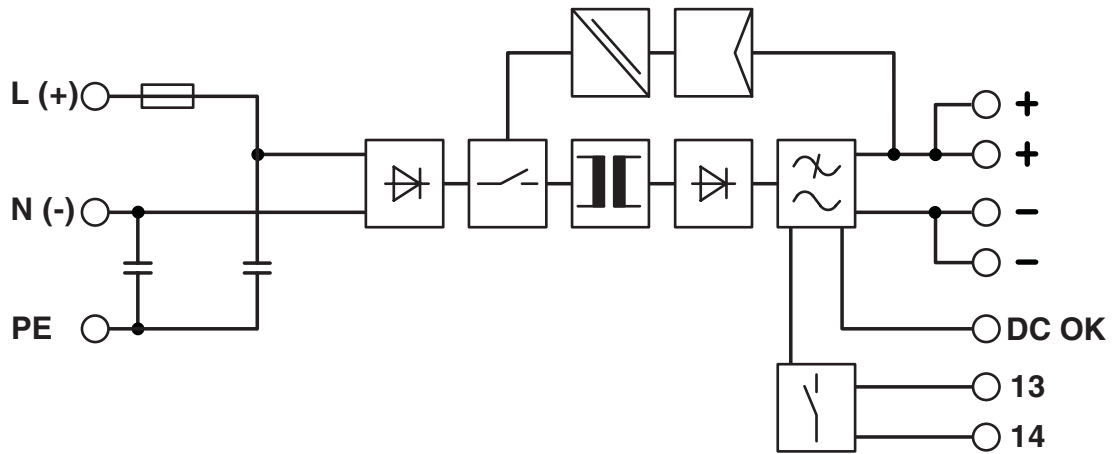

# QUINT-PS-100-240AC/24DC/ 5 - Power supply



2938581

<https://www.phoenixcontact.com/us/products/2938581>

## Classifications

### UNSPSC

UNSPSC 21.0	39121000
-------------	----------

# QUINT-PS-100-240AC/24DC/ 5 - Power supply



2938581

<https://www.phoenixcontact.com/us/products/2938581>

## Environmental product compliance

### EU RoHS

Fulfills EU RoHS substance requirements	Yes
Exemption	7(a), 7(c)-I

### China RoHS

Environment friendly use period (EFUP)	EFUP-25
	An article-related China RoHS declaration table can be found in the download area for the respective article under "Manufacturer declaration". For all articles with EFUP-E, no China RoHS declaration table issued and required.

### EU REACH SVHC

REACH candidate substance (CAS No.)	Lead(CAS: 7439-92-1)
-------------------------------------	----------------------

Phoenix Contact 2026 © - all rights reserved  
<https://www.phoenixcontact.com>

Phoenix Contact USA  
586 Fulling Mill Road  
Middletown, PA 17057, United States  
(+717) 944-1300  
[info@phoenixcon.com](mailto:info@phoenixcon.com)