

EG 45-A/ABS BK - Upper housing part

2909688

<https://www.phoenixcontact.com/us/products/2909688>

Please be informed that the data shown in this PDF document is generated from our online catalog. Please find the complete data in the user documentation. Our general terms of use for downloads are valid.



Component housing, Cover, for two-sided connection, width: 45 mm, height: 75 mm, color: black (similar RAL 9005)

The figure shows fully mounted versions of the electronic housing, in green

Your advantages

- Tool-free mounting

Commercial data

Item number	2909688
Packing unit	100 pc
Minimum order quantity	100 pc
Note	Made to order (non-returnable)
Product key	ACHCGA
GTIN	4017918406608
Weight per piece (including packing)	19.56 g
Weight per piece (excluding packing)	11.031 g
Country of origin	PL

EG 45-A/ABS BK - Upper housing part

2909688

<https://www.phoenixcontact.com/us/products/2909688>

Technical data

Product properties

Product type	Upper housing part
Housing type	Component housing
Housing series	EG
Product family	EG...A
Number of positions	16
Number (Connection openings)	2
Ventilation openings present	no

Dimensions

Dimensional drawing	
Width	45 mm
Height	75 mm

PCB design

PCB thickness	1.4 mm ... 1.8 mm
---------------	-------------------

Material specifications

Color (Upper housing part)	black (RAL 9005)
Material Upper housing part	ABS
Flammability rating according to UL 94	HB

Environmental and real-life conditions

Ambient conditions

Max. IP code to attain	IP20
Ambient temperature (operation)	-40 °C ... 80 °C (depending on power dissipation)
Ambient temperature (storage/transport)	-40 °C ... 55 °C
Ambient temperature (assembly)	-5 °C ... 80 °C

PCB data

Thickness of the PCB	1.4 mm ... 1.8 mm
----------------------	-------------------

Mounting

Mounting type	Snap in
---------------	---------

EG 45-A/ABS BK - Upper housing part

2909688

<https://www.phoenixcontact.com/us/products/2909688>



Drawings

Dimensional drawing

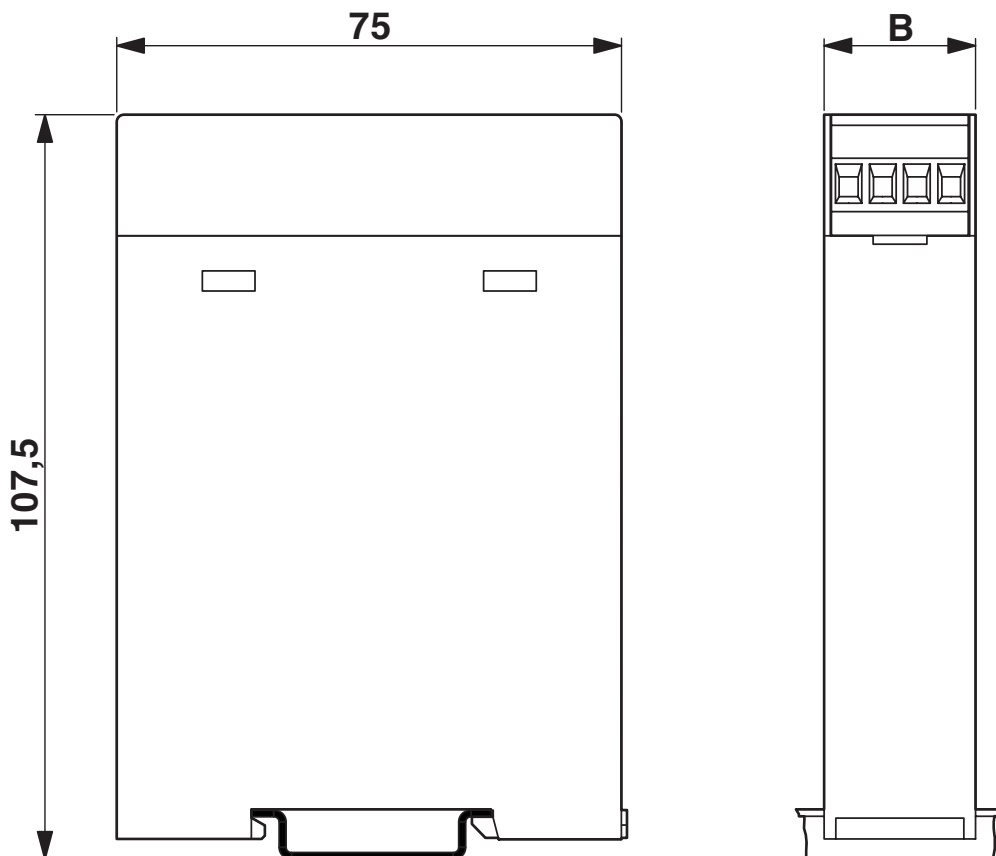

EG 45-A/ABS BK - Upper housing part



2909688

<https://www.phoenixcontact.com/us/products/2909688>



Component mounting side, if the double-level upper part is used

EG 45-A/ABS BK - Upper housing part

2909688

<https://www.phoenixcontact.com/us/products/2909688>



valid for PCB 1; 3; 5 and 6, see explosion drawing

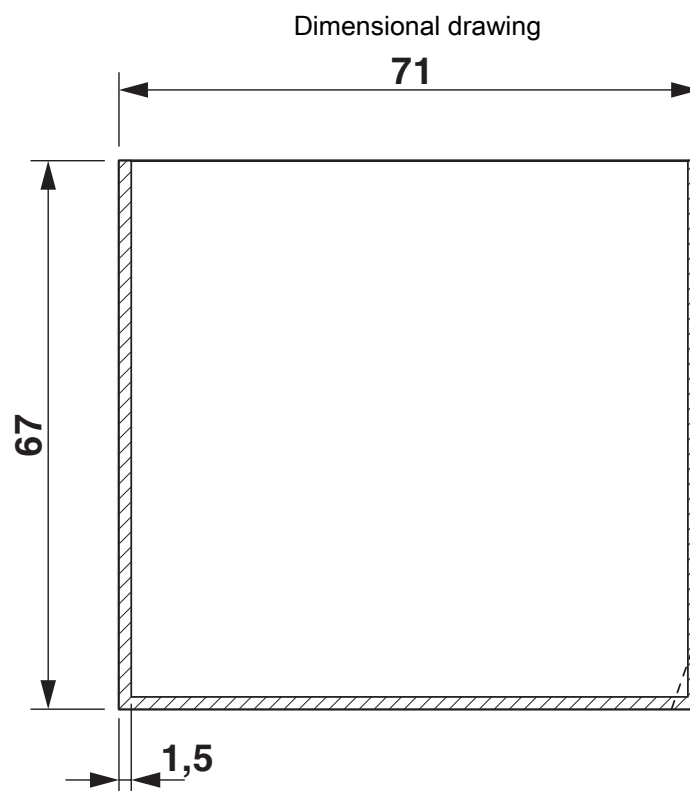

valid for PCB 7 and 12, see explosion drawing

EG 45-A/ABS BK - Upper housing part

2909688

<https://www.phoenixcontact.com/us/products/2909688>



valid for PCB 10, see explosion drawing

EG 45-A/ABS BK - Upper housing part

2909688

<https://www.phoenixcontact.com/us/products/2909688>



valid for PCB 13

EG 45-A/ABS BK - Upper housing part

2909688

<https://www.phoenixcontact.com/us/products/2909688>



valid for PCB 14

EG 45-A/ABS BK - Upper housing part



2909688

<https://www.phoenixcontact.com/us/products/2909688>

Approvals

To download certificates, visit the product detail page: <https://www.phoenixcontact.com/us/products/2909688>



UL Recognized

Approval ID: E240868

EG 45-A/ABS BK - Upper housing part



2909688

<https://www.phoenixcontact.com/us/products/2909688>

Classifications

ECLASS

ECLASS-13.0	27190603
ECLASS-15.0	27190603

ETIM

ETIM 10.0	EC002779
-----------	----------

UNSPSC

UNSPSC 21.0	31261500
-------------	----------

EG 45-A/ABS BK - Upper housing part



2909688

<https://www.phoenixcontact.com/us/products/2909688>

Environmental product compliance

EU RoHS

Fulfills EU RoHS substance requirements	Yes, No exemptions
---	--------------------

China RoHS

Environment friendly use period (EFUP)	EFUP-E
	No hazardous substances above the limits

EU REACH SVHC

REACH candidate substance (CAS No.)	No substance above 0.1 wt%
-------------------------------------	----------------------------

Phoenix Contact 2026 © - all rights reserved
<https://www.phoenixcontact.com>

Phoenix Contact USA
586 Fulling Mill Road
Middletown, PA 17057, United States
(+717) 944-1300
info@phoenixcon.com