

ELR H3-I-PT- 24DC/500AC-3-P - Hybrid motor starter



2909563

<https://www.phoenixcontact.com/us/products/2909563>

Please be informed that the data shown in this PDF document is generated from our online catalog. Please find the complete data in the user documentation. Our general terms of use for downloads are valid.



Hybrid motor starter as an alternative to a conventional contactor circuit. Starts 3~ AC motors up to 3 A and offers motor protection. Possible supply and relay extension via DIN rail connector.

Product description

The modular 3-phase hybrid motor starter with direct start function and current monitoring provides the following functions: - Forward running - Motor overload protection Additional advantages are provided by using the DIN rail connector adapter (Item No. 2203861): - Power can also be supplied via the DIN rail connector by a system power supply (e. g., QUINT4-SYS...) or via the PCB connector IMC 1,5/ 5-ST-3,81, Item No. 1857919 - Optional relay module (e. g., EM-2RSC/21AU-R/L-P, Item No. 2908701) provides additional status information

Commercial data

Item number	2909563
Packing unit	1 pc
Minimum order quantity	1 pc
Sales key	C470
Product key	DK7481
GTIN	4055626406633
Weight per piece (including packing)	242.22 g
Weight per piece (excluding packing)	292 g
Customs tariff number	85371098
Country of origin	DE

ELR H3-I-PT- 24DC/500AC-3-P - Hybrid motor starter



2909563

<https://www.phoenixcontact.com/us/products/2909563>

Technical data

Product properties

Product type	Hybrid motor starters
Product family	CONTACTRON
Operating mode	100% operating factor

Electrical properties

Number of phases	3
Motor starter type	Direct starter
Switching frequency	≤ 2 Hz (Load-dependent)
Switching frequency	≤ 2 Hz (Load-dependent)
Maximum power dissipation	4.1 W
Minimum power dissipation	0.88 W
Coordination type	1

Supply

Rated control circuit supply voltage U_S	24 V DC
Control supply voltage range	19.2 V DC ... 30 V DC
Rated control supply current I_S	60 mA
Protective circuit	Surge protection Reverse polarity protection; Parallel polarity protection diode

Insulation characteristics

Rated insulation voltage	550 V
Rated surge voltage	6 kV
Overvoltage category	III
Degree of pollution	2
Insulation characteristics between the control input and control supply voltage, and auxiliary circuit to the main circuit	Safe isolation (IEC 60947-1)
Isolation characteristics between the control input and control supply voltage to auxiliary circuit	Safe isolation (IEC 60947-1) in the auxiliary circuit ≤ 300 V AC

Emergency tripping

Operate threshold	> 33 A
Response time	< 0.5 s

Input data

Control

Input name	Control input
Rated actuating voltage U_C	24 V DC
Triggering voltage range	19.2 V DC ... 30 V DC
Rated actuating current I_C	7 mA
Switching threshold	9.6 V ("0" signal) 19.2 V ("1" signal)

ELR H3-I-PT- 24DC/500AC-3-P - Hybrid motor starter



2909563

<https://www.phoenixcontact.com/us/products/2909563>

Typical turn-off time	< 30 ms
Protective circuit	Reverse polarity protection

Output data

AC output

Rated operating voltage U_e	500 V AC
Operating voltage range	42 V AC ... 550 V AC
Rated operating current I_e	3 A (AC-51) 3 A (AC-53a)
Mains frequency	50/60 Hz
Load current range	180 mA ... 3 A
Trigger characteristic in acc. with IEC 60947-4-2	Class 10
Cooling time	20 min (for auto reset)
Leakage current	0 mA
Protective circuit	Surge protection; Varistor

Acknowledge output

Note	Confirmation: floating change-over contact, signal contact
Contact switching type	1 changeover contact
Switching capacity in accordance with IEC 60947-5-1	2 A (24 V (DC13))

Connection data

Control circuits

Connection method	Push-in connection
Stripping length	10 mm
Conductor cross-section rigid	0.2 mm ² ... 2.5 mm ²
Conductor cross-section flexible	0.2 mm ² ... 2.5 mm ²
Conductor cross-section AWG	24 ... 14

Load circuit

Connection method	Push-in connection
Stripping length	10 mm
Conductor cross-section rigid	0.2 mm ² ... 2.5 mm ²
Conductor cross-section flexible	0.2 mm ² ... 2.5 mm ²
Conductor cross-section AWG	24 ... 14

Signaling

Status display	LED (yellow)
Operating voltage display	Green LED
Error indication	Red LED

Dimensions

Width	22.5 mm
Height	107.5 mm

ELR H3-I-PT- 24DC/500AC-3-P - Hybrid motor starter



2909563

<https://www.phoenixcontact.com/us/products/2909563>

Depth	114 mm
-------	--------

Material specifications

Flammability rating according to UL 94 (Housing)	V0 (Housing)
--	--------------

Environmental and real-life conditions

Ambient conditions

Degree of protection	IP20
Ambient temperature (operation)	-25 °C ... 70 °C (observe derating)
Ambient temperature (storage/transport)	-40 °C ... 80 °C
Altitude	≤ 2000 m

Approvals

UL approval

Certificate	NLDX.E228652
	NRNT.E172140

UL data

SCCR	100 kA (480 V AC (fuse: 30 A class CC/30 A class J (high fault)))
	5 kA (480 V AC (fuse: 20 A RK5 (standard fault)))
FLA	3 A (480 V AC)
Group installation	20 A (class RK5, SCCR 5kA (480 V AC), #24 - 14 AWG max. solid and stranded)
	30 A (class CC or J, SCCR 100kA (480 V AC), #24 - 14 AWG max. solid and stranded)
Category code	NLDX / NRNT
Horsepower ratings	0.5 hp (208 V AC)
	0.5 hp (230 V AC)
	0.5 hp (240 V AC)
	1.5 hp (480 V AC)
Ambient temperature (operation)	-25 °C ... 55 °C

Standards and regulations

Standards/regulations

Standards/regulations	EN 60947-1
	EN 60947-4-2

Mounting

Mounting type	DIN rail mounting
Assembly note	alignable, for spacing see derating
Mounting position	vertical (horizontal DIN rail, motor output below)

Drawings

Block diagram

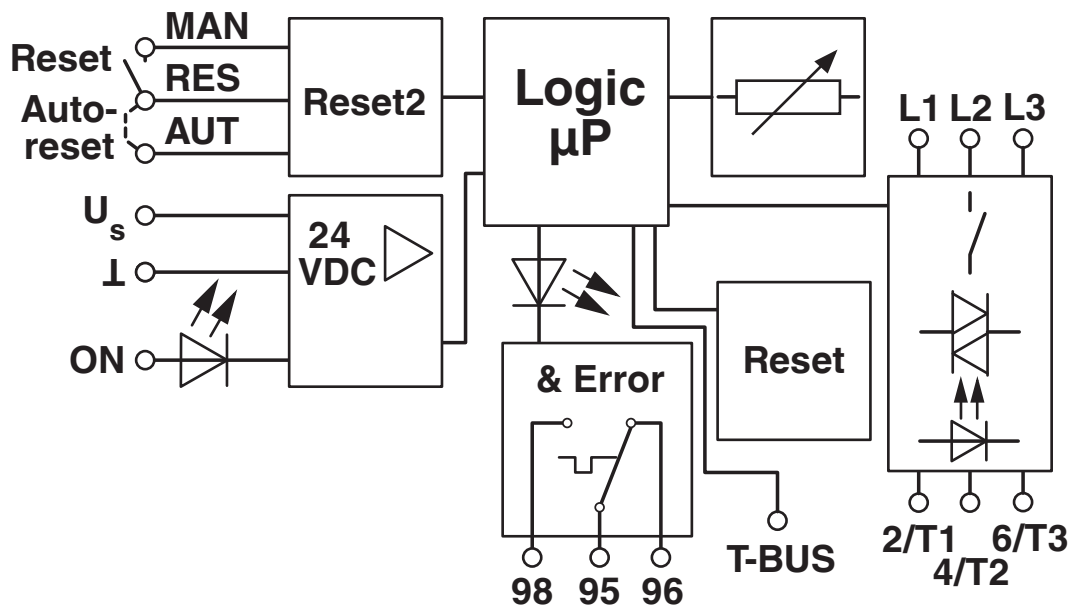

2909563

<https://www.phoenixcontact.com/us/products/2909563>

Approvals

To download certificates, visit the product detail page: <https://www.phoenixcontact.com/us/products/2909563>



IECEE CB Scheme

Approval ID: CB-DE1-60807-A1



EAC

Approval ID: RU*C-DE.*08.B.00520*



UL Listed

Approval ID: FILE E 172140



cUL Listed

Approval ID: FILE E 172140



cUL Listed

Approval ID: E228652



UL Listed

Approval ID: E228652



VDE Zeichengenehmigung

Approval ID: 40054426



CCC

Approval ID: 2024010304672814

DNV

Approval ID: TAA00002HK

2909563

<https://www.phoenixcontact.com/us/products/2909563>

Classifications

ECLASS

ECLASS-13.0	27370905
ECLASS-15.0	27370905

ETIM

ETIM 10.0	EC001037
-----------	----------

UNSPSC

UNSPSC 21.0	25173900
-------------	----------

2909563

<https://www.phoenixcontact.com/us/products/2909563>

Environmental product compliance

EU RoHS

Fulfills EU RoHS substance requirements	Yes
Exemption	7(a), 7(c)-I

China RoHS

Environment friendly use period (EFUP)	EFUP-50
	An article-related China RoHS declaration table can be found in the download area for the respective article under "Manufacturer declaration". For all articles with EFUP-E, no China RoHS declaration table issued and required.

EU REACH SVHC

REACH candidate substance (CAS No.)	Lead(CAS: 7439-92-1)
SCIP	1d9acce3-b6c5-411b-ae13-30ec0c23e427

Phoenix Contact 2026 © - all rights reserved

<https://www.phoenixcontact.com>

Phoenix Contact USA
586 Fulling Mill Road
Middletown, PA 17057, United States
(+717) 944-1300
info@phoenixcon.com