

FLX-D25F/8CH/AO/TDC3K - Termination board



2908886

<https://www.phoenixcontact.com/us/products/2908886>

Please be informed that the data shown in this PDF document is generated from our online catalog. Please find the complete data in the user documentation. Our general terms of use for downloads are valid.

Migration board for converting TDC3000 to modern control platforms, analog output, 8 channel



Your advantages

- Panel mount to existing TDC3000 chassis
- Compatible with existing pluggable field wiring connectors
- DSUB control side connection
- Terminal blocks for power supply

Commercial data

Item number	2908886
Packing unit	1 pc
Minimum order quantity	1 pc
Sales key	C421
Product key	DK2B8H
GTIN	4055626477909
Weight per piece (including packing)	307 g
Weight per piece (excluding packing)	300 g
Customs tariff number	85371098
Country of origin	US

FLX-D25F/8CH/AO/TDC3K - Termination board



2908886

<https://www.phoenixcontact.com/us/products/2908886>

Technical data

Product properties

Product type	Interface module
--------------	------------------

Insulation characteristics

Overvoltage category	II
Pollution degree	2

Electrical properties

Operating voltage	30 V DC
Max. current carrying capacity per branch	500 mA

Supported controller: HONEYWELL TDC3000

Suitable I/O card	TAOX02
	TAOX12

Connection data

Controller level

Connection method	D-SUB-25 female connector
Number of connections	1
Number of positions	25

Field level

Connection method	pluggable
-------------------	-----------

Dimensions

Item dimensions

Width	152.4 mm
Height	120.7 mm
Depth	38.3 mm

Environmental and real-life conditions

Ambient conditions

Ambient temperature (operation)	-40 °C ... 70 °C
Ambient temperature (storage/transport)	-40 °C ... 75 °C
Altitude	< 2000 m
Permissible humidity (operation)	< 90 %

Mounting

Mounting type	TDC3000 chassis
Mounting position	any

Notes

FLX-D25F/8CH/AO/TDC3K - Termination board



2908886

<https://www.phoenixcontact.com/us/products/2908886>

Notes on operation

For proper use, the specifications of the installation directive (see Downloads) must be observed. For applications or use with third-party products, the specifications, and the safety and warning instructions of the respective third-party manufacturer must also be met.

FLX-D25F/8CH/AO/TDC3K - Termination board



2908886

<https://www.phoenixcontact.com/us/products/2908886>

Drawings

Dimensional drawing

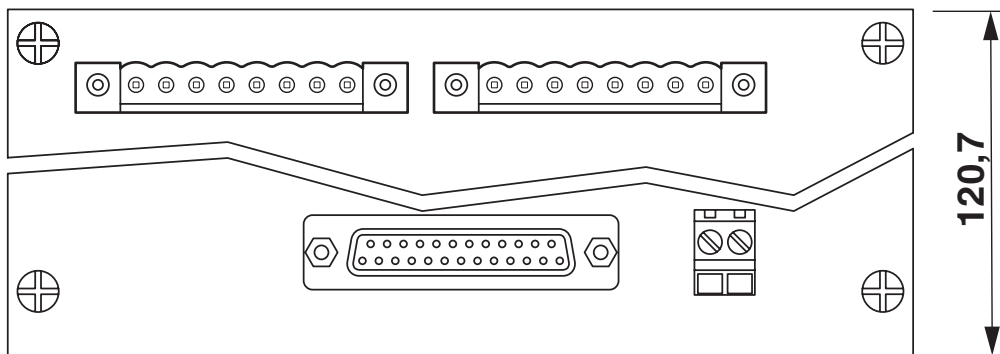
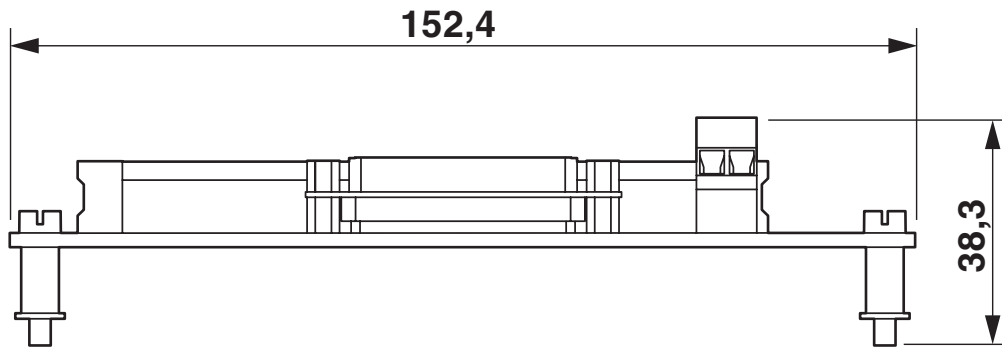

Circuit diagram

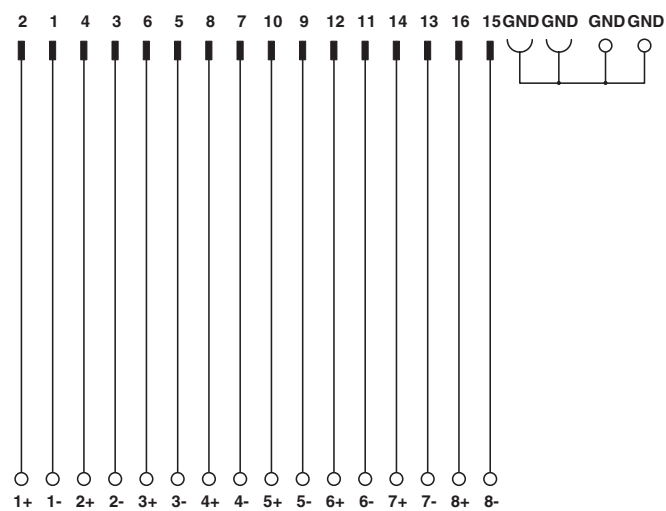

FLX-D25F/8CH/AO/TDC3K - Termination board





2908886

<https://www.phoenixcontact.com/us/products/2908886>

Approvals

To download certificates, visit the product detail page: <https://www.phoenixcontact.com/us/products/2908886>

 CSA Approval ID: 108860_0_000				
	Nominal voltage U_N	Nominal current I_N	Cross section AWG	Cross section mm^2
keine	-	0.5 A	-	-

 cUL Recognized Approval ID: FILE E 238705				
	Nominal voltage U_N	Nominal current I_N	Cross section AWG	Cross section mm^2
keine	-	0.5 A	-	-

 UL Recognized Approval ID: FILE E 238705				
	Nominal voltage U_N	Nominal current I_N	Cross section AWG	Cross section mm^2
keine	-	0.5 A	-	-

 CSAus Approval ID: 108860_0_000				
	Nominal voltage U_N	Nominal current I_N	Cross section AWG	Cross section mm^2
keine	-	0.5 A	-	-

FLX-D25F/8CH/AO/TDC3K - Termination board



2908886

<https://www.phoenixcontact.com/us/products/2908886>

Classifications

ECLASS

ECLASS-13.0	27141152
ECLASS-15.0	27141152

ETIM

ETIM 10.0	EC002780
-----------	----------

UNSPSC

UNSPSC 21.0	39121400
-------------	----------

FLX-D25F/8CH/AO/TDC3K - Termination board



2908886

<https://www.phoenixcontact.com/us/products/2908886>

Environmental product compliance

EU RoHS

Fulfills EU RoHS substance requirements	Yes
Exemption	6(c)

China RoHS

Environment friendly use period (EFUP)	EFUP-50
	An article-related China RoHS declaration table can be found in the download area for the respective article under "Manufacturer declaration". For all articles with EFUP-E, no China RoHS declaration table issued and required.

EU REACH SVHC

REACH candidate substance (CAS No.)	Lead(CAS: 7439-92-1)
SCIP	e6d5d260-8f3c-4cc5-b753-8cb2d05e95b6

Phoenix Contact 2026 © - all rights reserved

<https://www.phoenixcontact.com>

Phoenix Contact USA
586 Fulling Mill Road
Middletown, PA 17057, United States
(+717) 944-1300
info@phoenixcon.com