

# FLX-D25F/16CH/AI/TDC3K - Termination board



2908885

<https://www.phoenixcontact.com/us/products/2908885>

Please be informed that the data shown in this PDF document is generated from our online catalog. Please find the complete data in the user documentation. Our general terms of use for downloads are valid.

Migration board for converting TDC3000 to modern control platforms, analog input, 16 channel



## Your advantages

- Panel mount to existing TDC3000 chassis
- Compatible with existing pluggable field wiring connectors
- DSUB control side connection
- Terminal blocks for power supply

## Commercial data

Item number	2908885
Packing unit	1 pc
Minimum order quantity	1 pc
Sales key	C421
Product key	DK2B8H
GTIN	4055626477923
Weight per piece (including packing)	492 g
Weight per piece (excluding packing)	460 g
Customs tariff number	85371098
Country of origin	US

# FLX-D25F/16CH/AI/TDC3K - Termination board



2908885

<https://www.phoenixcontact.com/us/products/2908885>

## Technical data

### Product properties

Product type	Interface module
--------------	------------------

### Insulation characteristics

Overvoltage category	II
Pollution degree	2

### Electrical properties

Operating voltage	30 V DC
Current (per branch)	≤ 250 mA

Supported controller: HONEYWELL TDC3000

Suitable I/O card	TAIH12
	TAIH13

### Connection data

#### Controller level

Connection method	D-SUB-25 female connector
Number of connections	2
Number of positions	25

#### Field level

Connection method	pluggable
-------------------	-----------

### Dimensions

#### Item dimensions

Width	307.3 mm
Height	120.7 mm
Depth	38.3 mm

### Environmental and real-life conditions

#### Ambient conditions

Ambient temperature (operation)	-40 °C ... 70 °C
Ambient temperature (storage/transport)	-40 °C ... 75 °C
Altitude	< 2000 m
Permissible humidity (operation)	< 90 %

### Mounting

Mounting position	any
-------------------	-----

### Notes

Notes on operation	For proper use, the specifications of the installation directive (see
--------------------	---

# FLX-D25F/16CH/AI/TDC3K - Termination board



2908885

<https://www.phoenixcontact.com/us/products/2908885>

Downloads) must be observed. For applications or use with third-party products, the specifications, and the safety and warning instructions of the respective third-party manufacturer must also be met.

# FLX-D25F/16CH/AI/TDC3K - Termination board



2908885

<https://www.phoenixcontact.com/us/products/2908885>

## Drawings

Dimensional drawing

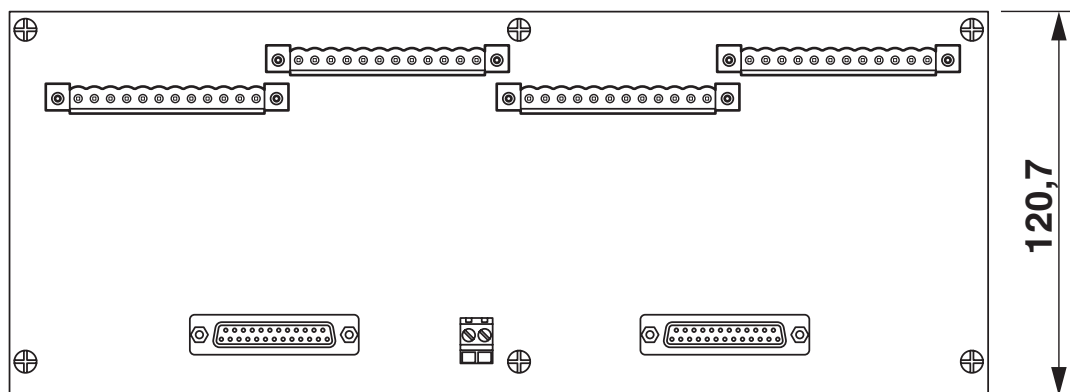
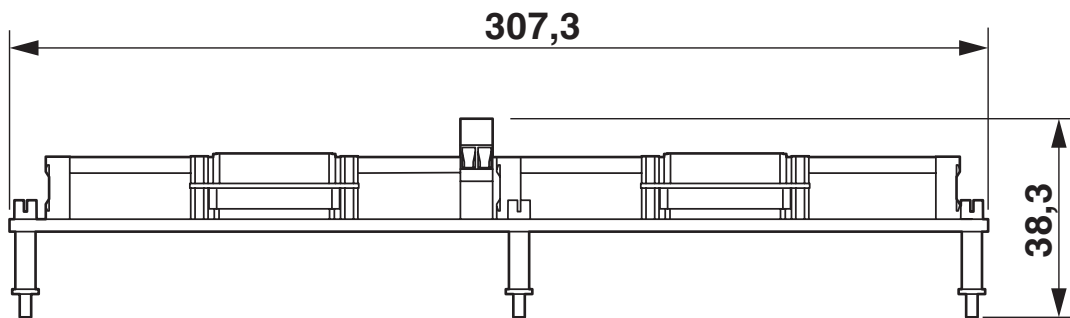

Circuit diagram

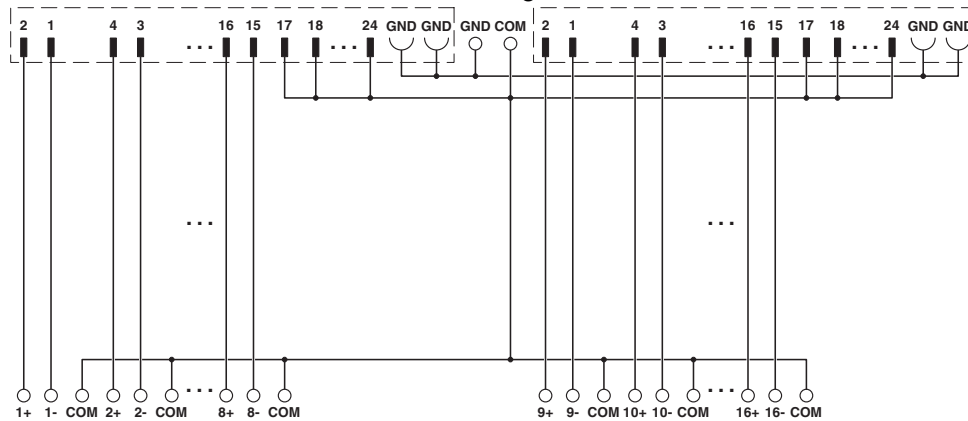

# FLX-D25F/16CH/AI/TDC3K - Termination board





2908885

<https://www.phoenixcontact.com/us/products/2908885>

## Approvals

To download certificates, visit the product detail page: <https://www.phoenixcontact.com/us/products/2908885>

 <b>CSA</b> Approval ID: 108860_0_000				
	Nominal voltage $U_N$	Nominal current $I_N$	Cross section AWG	Cross section $\text{mm}^2$
keine	-	0.25 A	-	-

 <b>cUL Recognized</b> Approval ID: FILE E 238705				
	Nominal voltage $U_N$	Nominal current $I_N$	Cross section AWG	Cross section $\text{mm}^2$
keine	-	0.25 A	-	-

 <b>UL Recognized</b> Approval ID: FILE E 238705				
	Nominal voltage $U_N$	Nominal current $I_N$	Cross section AWG	Cross section $\text{mm}^2$
keine	-	0.25 A	-	-

 <b>CSAus</b> Approval ID: 108860_0_000				
	Nominal voltage $U_N$	Nominal current $I_N$	Cross section AWG	Cross section $\text{mm}^2$
keine	-	0.25 A	-	-

# FLX-D25F/16CH/AI/TDC3K - Termination board



2908885

<https://www.phoenixcontact.com/us/products/2908885>

## Classifications

### ECLASS

ECLASS-13.0	27141152
ECLASS-15.0	27141152

### ETIM

ETIM 10.0	EC002780
-----------	----------

### UNSPSC

UNSPSC 21.0	39121400
-------------	----------

# FLX-D25F/16CH/AI/TDC3K - Termination board



2908885

<https://www.phoenixcontact.com/us/products/2908885>

## Environmental product compliance

### EU RoHS

Fulfills EU RoHS substance requirements	Yes
Exemption	6(c)

### China RoHS

Environment friendly use period (EFUP)	EFUP-50
	An article-related China RoHS declaration table can be found in the download area for the respective article under "Manufacturer declaration". For all articles with EFUP-E, no China RoHS declaration table issued and required.

### EU REACH SVHC

REACH candidate substance (CAS No.)	Lead(CAS: 7439-92-1)
SCIP	2f567388-881c-485b-bdc9-9262c66082c3

Phoenix Contact 2026 © - all rights reserved

<https://www.phoenixcontact.com>

Phoenix Contact USA  
586 Fulling Mill Road  
Middletown, PA 17057, United States  
(+717) 944-1300  
[info@phoenixcon.com](mailto:info@phoenixcon.com)