

FA MCR-FDS-I-I-OLP - Digital display



2908782

<https://www.phoenixcontact.com/us/products/2908782>

Please be informed that the data shown in this PDF document is generated from our online catalog. Please find the complete data in the user documentation. Our general terms of use for downloads are valid.

Output loop-powered process indicator in field housing. HART



Commercial data

Item number	2908782
Packing unit	1 pc
Minimum order quantity	1 pc
Sales key	C401
Product key	DK1141
GTIN	4055626357096
Weight per piece (including packing)	816 g
Weight per piece (excluding packing)	800.2 g
Customs tariff number	90328900
Country of origin	DE

Technical data

Product properties

Product type	Digital displays
Product family	Field Analog
Configuration	Keyboard
	Software

System properties

Functionality

Configuration	Keyboard
	Software

Electrical properties

Maximum temperature coefficient	< 0.02 %/K
Maximum transmission error	0.1 % (of final value)

Supply

Supply voltage range	loop-powered, no external supply necessary
----------------------	--

Input data

Signal: Current

Current input signal	4 mA ... 20 mA
Max. current input signal	200 mA
Voltage drop	≤ 1 V
	≤ 3.9 V (with display lighting)
Input impedance	≈ $\ominus \downarrow \Omega$

Signal: HART

Current input signal	up to 4x HART process variables
Voltage drop	≤ 1.9 V
	≤ 4.8 V (with display lighting)
Input impedance	$R_x = 40 \Omega / C_x = 2.3 \text{ nF}$

Output data

Signal: Current

Current output signal	4 mA ... 20 mA
Number of positions displayed	5
Display	7-segment LC display, with backlight, dot matrix for text/bar graph
Display value	scalable

Signal: HART

Current output signal	up to 4x HART process variables
-----------------------	---------------------------------

FA MCR-FDS-I-I-OLP - Digital display



2908782

<https://www.phoenixcontact.com/us/products/2908782>

Connection data

Connection method	Push-in connection
Stripping length	9 mm
Conductor cross-section rigid	0.14 mm ² ... 1.5 mm ²
Conductor cross-section flexible	0.14 mm ² ... 1.5 mm ²
Conductor cross-section AWG	26 ... 16

Interfaces

Data communication (bypass)

Protocols supported	HART
---------------------	------

Dimensions

Width	131 mm
Height	81.5 mm
Depth	55.5 mm

Material specifications

Color	light gray (RAL 7035)
Housing material	Aluminum

Environmental and real-life conditions

Ambient conditions

Degree of protection	IP66/IP67 NEMA 4X
Ambient temperature (operation)	-40 °C ... 60 °C
Ambient temperature (storage/transport)	-40 °C ... 85 °C
Altitude	< 5000 m (Above sea level)
Climatic class	according to IEC 60654-1, class B2

Approvals

CE

Certificate	CE-compliant
-------------	--------------

UL, USA/Canada

Identification	UL 61010 Listed
----------------	-----------------

Shipbuilding approval

Certificate	DNV GL TAA000013C
-------------	-------------------

Shipbuilding data

Temperature	B
Humidity	B
Vibration	A
EMC	B

FA MCR-FDS-I-I-OLP - Digital display



2908782

<https://www.phoenixcontact.com/us/products/2908782>

Enclosure	Required protection according to the Rules shall be provided upon installation on board
-----------	---

EMC data

Noise emission

Standards/regulations	IEC 61326, class B
-----------------------	--------------------

Mounting

Mounting type	Panel mounting
	Tube mounting
Mounting position	Max. viewing angle range +/- 45° from the centre line of the display in every direction

FA MCR-FDS-I-I-OLP - Digital display

2908782

<https://www.phoenixcontact.com/us/products/2908782>

Drawings

Block diagram

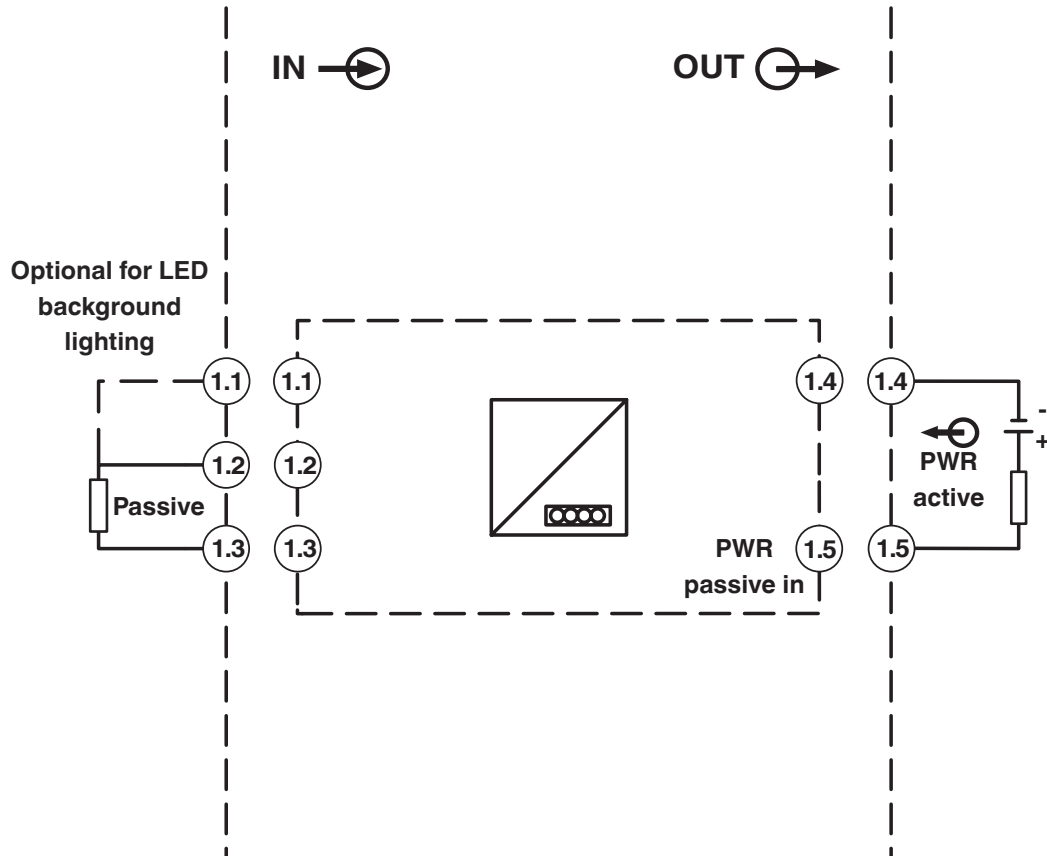

FA MCR-FDS-I-I-OLP

FA MCR-FDS-I-I-OLP - Digital display



2908782

<https://www.phoenixcontact.com/us/products/2908782>

Classifications

ECLASS

ECLASS-13.0	27210301
ECLASS-15.0	27210301

ETIM

ETIM 9.0	EC011349
----------	----------

UNSPSC

UNSPSC 21.0	39121000
-------------	----------

2908782

<https://www.phoenixcontact.com/us/products/2908782>

Environmental product compliance

EU RoHS

Fulfills EU RoHS substance requirements	Yes
Exemption	7(a), 7(c)-I

China RoHS

Environment friendly use period (EFUP)	EFUP-50
	An article-related China RoHS declaration table can be found in the download area for the respective article under "Manufacturer declaration". For all articles with EFUP-E, no China RoHS declaration table issued and required.

EU REACH SVHC

REACH candidate substance (CAS No.)	Lead(CAS: 7439-92-1)
-------------------------------------	----------------------

Phoenix Contact 2026 © - all rights reserved
<https://www.phoenixcontact.com>

Phoenix Contact USA
586 Fulling Mill Road
Middletown, PA 17057, United States
(+717) 944-1300
info@phoenixcon.com