

# EMG 15-LG - Electronics housing



2908508

<https://www.phoenixcontact.com/us/products/2908508>

Please be informed that the data shown in this PDF document is generated from our online catalog. Please find the complete data in the user documentation. Our general terms of use for downloads are valid.

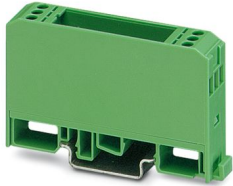

Electronic housing, with universal foot, for PCB insertion, without screw connection terminal blocks and cover

## Commercial data

Item number	2908508
Packing unit	10 pc
Minimum order quantity	10 pc
Sales key	AC11
Product key	ACHCBA
GTIN	4017918158040
Weight per piece (including packing)	16.74 g
Weight per piece (excluding packing)	16.74 g
Customs tariff number	84879090
Country of origin	DE



# EMG 15-LG - Electronics housing

2908508

<https://www.phoenixcontact.com/us/products/2908508>



## Drawings

Dimensional drawing



1 = Top edge of the PCB  
B = Housing width

# EMG 15-LG - Electronics housing

2908508

<https://www.phoenixcontact.com/us/products/2908508>

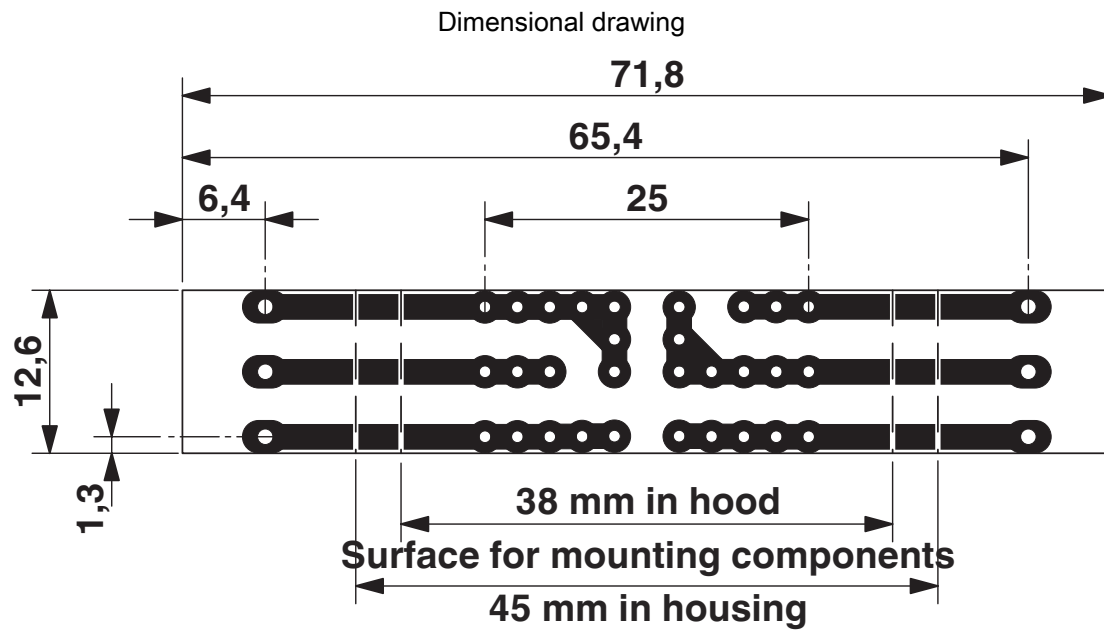

Pitch 5 mm

a = Area for mounting components, 38 mm in the hood

b = Area for mounting components, 45 mm in the housing

# EMG 15-LG - Electronics housing

2908508

<https://www.phoenixcontact.com/us/products/2908508>



## Classifications

### ECLASS

ECLASS-13.0	27190101
ECLASS-15.0	27190101

### ETIM

ETIM 10.0	EC001031
-----------	----------

### UNSPSC

UNSPSC 21.0	31261500
-------------	----------

# EMG 15-LG - Electronics housing



2908508

<https://www.phoenixcontact.com/us/products/2908508>

## Environmental product compliance

### EU RoHS

Fulfills EU RoHS substance requirements	Yes, No exemptions
---	--------------------

### China RoHS

Environment friendly use period (EFUP)	EFUP-E
	No hazardous substances above the limits

### EU REACH SVHC

REACH candidate substance (CAS No.)	No substance above 0.1 wt%
-------------------------------------	----------------------------

Phoenix Contact 2026 © - all rights reserved  
<https://www.phoenixcontact.com>

Phoenix Contact USA  
586 Fulling Mill Road  
Middletown, PA 17057, United States  
(+717) 944-1300  
[info@phoenixcon.com](mailto:info@phoenixcon.com)