

TTC-6P-1X2-12DC-PT-I - Surge protection device



2908193

<https://www.phoenixcontact.com/us/products/2908193>

Please be informed that the data shown in this PDF document is generated from our online catalog. Please find the complete data in the user documentation. Our general terms of use for downloads are valid.



Surge protection, consisting of protective plug and base element, with integrated status indicator for a 2-wire floating signal circuit. Can be used in safety-related circuits up to SIL 3.

Your advantages

- Space-saving and cost-saving with a narrow overall width of just 6 mm
- Continuous monitoring of protective devices, plus mechanical status indicator with optional remote signaling
- Finding the right product for all possible requirements in MCR applications is easy, thanks to the complete range of products with customized features
- Easy testing and documentation with CHECKMASTER 2 with pluggable protective modules
- The signal is not influenced during maintenance work, thanks to the impedance-neutral insertion and removal of protective plugs

Commercial data

| | |
|--------------------------------------|---------------|
| Item number | 2908193 |
| Packing unit | 1 pc |
| Minimum order quantity | 1 pc |
| Sales key | CL23 |
| Product key | CL2162 |
| GTIN | 4055626282688 |
| Weight per piece (including packing) | 41.125 g |
| Weight per piece (excluding packing) | 34.59 g |
| Customs tariff number | 85363010 |
| Country of origin | DE |

TTC-6P-1X2-12DC-PT-I - Surge protection device



2908193

<https://www.phoenixcontact.com/us/products/2908193>

Technical data

Product properties

| | |
|-------------------------|---|
| Product type | Surge protection for MCR technology |
| Product family | TERMITRAB complete |
| IEC test classification | C1 |
| | C2 |
| | C3 |
| | D1 |
| Type | DIN rail module, two-section, divisible |
| Wire pairs per module | 1 |

Insulation characteristics

| | |
|----------------------|-----|
| Overvoltage category | III |
| Pollution degree | 2 |

Electrical properties

| | |
|-----------------------|---------|
| Nominal voltage U_N | 12 V DC |
|-----------------------|---------|

Connection data

| | |
|----------------------------------|---|
| Connection method | Push-in connection |
| Conductor cross-section flexible | 0.2 mm ² ... 2.5 mm ² |
| Conductor cross-section rigid | 0.2 mm ² ... 4 mm ² |
| Conductor cross-section AWG | 24 ... 12 |

Dimensions

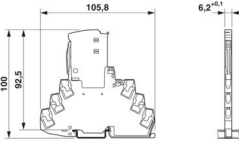
| | |
|---------------------|--|
| Dimensional drawing |  |
| Width | 6.2 mm +0.1 mm |
| Height | 105.8 mm |
| Depth | 100 mm (incl. DIN rail 7.5 mm) |

Material specifications

| | |
|--|-----------------------|
| Color (Base element) | gray (RAL 7042) |
| Color (Male connector) | light gray (RAL 7035) |
| Flammability rating according to UL 94 | V-0 |
| Insulating material | PBT |
| Housing material | PBT |

Mechanical properties

Mechanical data

TTC-6P-1X2-12DC-PT-I - Surge protection device



2908193

<https://www.phoenixcontact.com/us/products/2908193>

| | |
|-----------------|----|
| Open side panel | No |
|-----------------|----|

Protective circuit

| | |
|---|---|
| Direction of action | Line-Line & Line-Signal Ground/Shield & optional Signal Ground/Shield-Earth Ground |
| Nominal voltage U_N | 12 V DC |
| Maximum continuous operating voltage U_C | 15 V DC 10 V AC |
| Rated current | 600 mA (56 °C) |
| Operating effective current I_C at U_C | $\leq 100 \mu\text{A}$ |
| Protective conductor current I_{PE} | $\leq 1 \mu\text{A}$ |
| Nominal discharge current I_n (8/20) μs (line-line) | 5 kA |
| Nominal discharge current I_n (8/20) μs (line-ground) | 5 kA |
| Pulse discharge current I_{imp} (10/350) μs (line-line) | 0.5 kA |
| Pulse discharge current I_{imp} (10/350) μs (line-earth) | 0.5 kA |
| Total discharge current I_{Total} (8/20) μs | 10 kA |
| Voltage protection level U_p (line-line) | $\leq 220 \text{ V}$ (C1 - 1 kV / 500 A) $\leq 350 \text{ V}$ (C2 - 10 kV / 5 kA) $\leq 25 \text{ V}$ (C3 - 25 A) $\leq 35 \text{ V}$ (C3 - 100 A) |
| Voltage protection level U_p (line-earth) | $\leq 750 \text{ V}$ (C1 - 1 kV / 500 A) $\leq 750 \text{ V}$ (C2 - 10 kV / 5 kA) $\leq 700 \text{ V}$ (C3 - 25 A) $\leq 750 \text{ V}$ (C3 - 100 A) |
| Voltage protection level U_p static (line-line) | $\leq 30 \text{ V}$ (C1 - 1 kV / 500 A) $\leq 81 \text{ V}$ (C2 - 10 kV / 5 kA) |
| Voltage protection level U_p static (line-earth) | $\leq 750 \text{ V}$ (C1 - 1 kV / 500 A) $\leq 750 \text{ V}$ (C2 - 10 kV / 5 kA) |
| Response time t_A (line-line) | $\leq 1 \text{ ns}$ |
| Response time t_A (line-earth) | $\leq 100 \text{ ns}$ |
| Input attenuation aE, sym. | typ. 0.3 dB ($\leq 130 \text{ kHz}/150 \Omega$) |
| Cut-off frequency f_g (3 dB), sym. in 150 Ω system | typ. 420 kHz |
| Capacity (Core-Core) | typ. 5.2 nF |
| Resistance per path | 1.65 $\Omega \pm 20 \%$ |
| Surge protection fault message | optical |
| Max. required back-up fuse | 630 mA (FF) |
| Impulse durability (line-line) | C1 - 1 kV / 500 A C2 - 10 kV / 5 kA C3 - 100 A |
| Impulse durability (line-earth) | C1 - 1 kV / 500 A C2 - 10 kV / 5 kA C3 - 100 A D1 - 500 A |
| Pulse reset time (line-line) | $\leq 700 \text{ ms}$ |

TTC-6P-1X2-12DC-PT-I - Surge protection device



2908193

<https://www.phoenixcontact.com/us/products/2908193>

| | |
|-------------------------------|-----------|
| Pulse reset time (line-earth) | ≤ 1500 ms |
|-------------------------------|-----------|

Additional technical data

| | |
|--|------------|
| Max. total discharge current $I_{\text{total max}} (8/20) \mu\text{s}$ | 20 kA (1x) |
|--|------------|

Environmental and real-life conditions

Ambient conditions

| | |
|---|------------------|
| Degree of protection | IP20 |
| Ambient temperature (operation) | -40 °C ... 85 °C |
| Ambient temperature (storage/transport) | -40 °C ... 85 °C |
| Altitude | ≤ 4000 m (amsl) |
| Permissible humidity (operation) | 5 % ... 95 % |

Standards and regulations

| | |
|--------------------------|---|
| Standards/specifications | IEC 61643-21 |
| Note | 2000 + corrigendum 2001 + A1:2008, modified + A2:2012 |

EN 61643-21

| | |
|--------------------------|--------------------------|
| Standards/specifications | EN 61643-21 |
| Note | 2001 + A1:2009 + A2:2013 |

Mounting

| | |
|---------------|--------------------------|
| Mounting type | DIN rail: TH 35 - 7.5 mm |
|---------------|--------------------------|

TTC-6P-1X2-12DC-PT-I - Surge protection device



2908193

<https://www.phoenixcontact.com/us/products/2908193>

Drawings

Dimensional drawing



Schematic diagram

| TTC-6P-1x2-...-I | | | | | | | | | |
|------------------|--------------------------|---------------------------|--------------------------|-------|--------------------------|----------------------------|------|--------------------------|-------|
| Category | 1oo1 architecture, HFT=0 | | | | 1oo2 architecture, HFT=1 | | | | |
| | PFD _{AVG} | PFH | Used budget of SIL 2 SIF | | PFD _{AVG} | PFH | CCF | Used budget of SIL 3 SIF | |
| | | | PFD _{AVG} | PFH | | | | PFD _{AVG} | PFH |
| | 3.88x10 ⁻⁵ | 6.90x10 ⁻⁹ 1/h | 0.4 % | 0.7 % | 1.94x10 ⁻⁶ | 3.45x10 ⁻¹⁰ 1/h | 5 % | 0.2 % | 0.3 % |
| | | | | | 3.88x10 ⁻⁶ | 6.90x10 ⁻¹⁰ 1/h | 10 % | 0.4 % | 0.7 % |

Calculation based on exida report, Phoenix Contact 16/06-072 R022 V4R2
 exida Profile 1, FMEDA Analysis 2, T_{proof}: 1 year, MT: 10 years, MTTR: 24 hours, PTC: 99%
 Used standards
 IEC/EN 61508, edition 2010 (device specific)
 IEC/EN 61511, edition 2016 + COR1:2016 + A1:2017 (system specific)

Functional safety scenarios

Diagram



TTC-6P-1X2-12DC-PT-I - Surge protection device



2908193

<https://www.phoenixcontact.com/us/products/2908193>

Circuit diagram

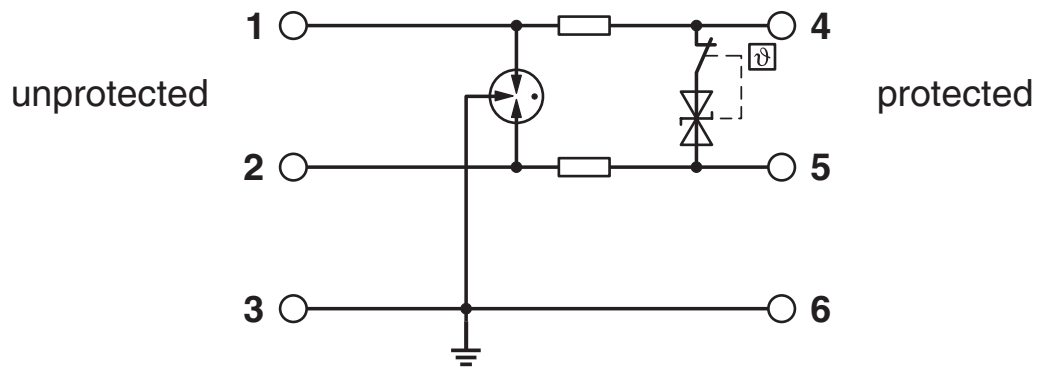

TTC-6P-1X2-12DC-PT-I - Surge protection device



2908193

<https://www.phoenixcontact.com/us/products/2908193>

Approvals

To download certificates, visit the product detail page: <https://www.phoenixcontact.com/us/products/2908193>



CSA

Approval ID: 70136717



DNV GL

Approval ID: TAE000027G



UL Listed

Approval ID: FILE E 138168



CSAus

Approval ID: 70136717

UAE-RoHS

Approval ID: 22-06-16192

Functional Safety

Approval ID: 16-06-072 R022 V4R3

TTC-6P-1X2-12DC-PT-I - Surge protection device



2908193

<https://www.phoenixcontact.com/us/products/2908193>

Classifications

ECLASS

| | |
|-------------|----------|
| ECLASS-13.0 | 27171501 |
| ECLASS-15.0 | 27171501 |

ETIM

| | |
|-----------|----------|
| ETIM 10.0 | EC001466 |
|-----------|----------|

UNSPSC

| | |
|-------------|----------|
| UNSPSC 21.0 | 39121600 |
|-------------|----------|

TTC-6P-1X2-12DC-PT-I - Surge protection device



2908193

<https://www.phoenixcontact.com/us/products/2908193>

Environmental product compliance

EU RoHS

| | |
|---|--------------|
| Fulfills EU RoHS substance requirements | Yes |
| Exemption | 7(a), 7(c)-I |

China RoHS

| | |
|--|---|
| Environment friendly use period (EFUP) | EFUP-50 |
| | An article-related China RoHS declaration table can be found in the download area for the respective article under "Manufacturer declaration". For all articles with EFUP-E, no China RoHS declaration table issued and required. |

EU REACH SVHC

| | |
|-------------------------------------|--------------------------------------|
| REACH candidate substance (CAS No.) | Lead(CAS: 7439-92-1) |
| SCIP | b9cf7c46-4878-4988-8565-1dd631590d6d |

EF3.1 Climate Change

| | |
|---------|---------------|
| CO2e kg | 1.328 kg CO2e |
|---------|---------------|

Phoenix Contact 2026 © - all rights reserved
<https://www.phoenixcontact.com>

Phoenix Contact USA
586 Fulling Mill Road
Middletown, PA 17057, United States
(+717) 944-1300
info@phoenixcon.com