

# TTC-6-3-HF-F-M-12DC-UT-I - Surge protection device



2906769

<https://www.phoenixcontact.com/us/products/2906769>

Please be informed that the data shown in this PDF document is generated from our online catalog. Please find the complete data in the user documentation. Our general terms of use for downloads are valid.



Surge protection with integrated status indicator and knife disconnection for three signal wires with common reference potential. For HF applications and telecommunications interfaces without supply voltage (up to 90 Mbps). Indirect grounding via gas discharge tube. Can be used in safety-related circuits up to SIL 3.

## Your advantages

- Space-saving and cost-saving with a narrow overall width of just 6 mm
- Continuous monitoring of protective devices, plus mechanical status indicator with optional remote signaling
- Finding the right product for all possible requirements in MCR applications is easy, thanks to the complete range of products with customized features
- Signal circuits easily interrupted for maintenance work, thanks to vertical knife disconnection

## Commercial data

Item number	2906769
Packing unit	1 pc
Minimum order quantity	1 pc
Sales key	CL23
Product key	CL2261
GTIN	4055626135182
Weight per piece (including packing)	43.7 g
Weight per piece (excluding packing)	36.74 g
Customs tariff number	85363010
Country of origin	DE

## Technical data

### Product properties

Product type	Surge protection for information technology
Product family	TERMITRAB complete
IEC test classification	C1
	C2
	C3
	D1
Type	DIN rail module, one-piece

### Insulation characteristics

Overvoltage category	III
Pollution degree	2

### Electrical properties

Nominal voltage $U_N$	12 V DC
-----------------------	---------

### Connection data

Connection method	Screw connection
Screw thread	M3
Tightening torque	0.5 Nm ... 0.6 Nm
Conductor cross-section flexible	0.2 mm <sup>2</sup> ... 2.5 mm <sup>2</sup>
Conductor cross-section rigid	0.2 mm <sup>2</sup> ... 4 mm <sup>2</sup>
Conductor cross-section AWG	24 ... 12

### Dimensions

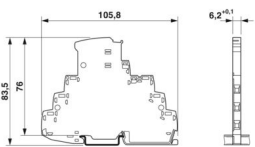
Dimensional drawing	
Width	6.2 mm +0.1 mm
Height	105.8 mm
Depth	83.5 mm (incl. DIN rail 7.5 mm)

### Material specifications

Color	gray (RAL 7042)
	light gray (RAL 7035)
Flammability rating according to UL 94	V-0
Insulating material	PBT
Housing material	PBT

### Mechanical properties

# TTC-6-3-HF-F-M-12DC-UT-I - Surge protection device



2906769

<https://www.phoenixcontact.com/us/products/2906769>

## Mechanical data

Open side panel	No
-----------------	----

## Protective circuit

Direction of action	Line-Line & Line-Signal Ground/Shield & optional Signal Ground/Shield-Earth Ground
Nominal voltage $U_N$	12 V DC
Maximum continuous operating voltage $U_C$	15 V DC 10 V AC
Rated current	600 mA (40 °C)
Operating effective current $I_C$ at $U_C$	$\leq 100 \mu\text{A}$
Protective conductor current $I_{PE}$	$\leq 1 \mu\text{A}$
Nominal discharge current $I_n$ (8/20) $\mu\text{s}$ (line-line)	5 kA
Nominal discharge current $I_n$ (8/20) $\mu\text{s}$ (line-ground)	5 kA
Pulse discharge current $I_{imp}$ (10/350) $\mu\text{s}$ (line-earth)	0.5 kA
Total discharge current $I_{Total}$ (8/20) $\mu\text{s}$	10 kA
Voltage protection level $U_p$ (line-line)	$\leq 120 \text{ V}$ (C2 - 10 kV / 5 kA) $\leq 25 \text{ V}$ (C3 - 25 A) $\leq 30 \text{ V}$ (C3 - 100 A)
Voltage protection level $U_p$ (line-earth)	$\leq 750 \text{ V}$ (C1 - 1 kV / 500 A) $\leq 750 \text{ V}$ (C2 - 10 kV / 5 kA) $\leq 1.1 \text{ kV}$ (C3 - 25 A) $\leq 1.2 \text{ kV}$ (C3 - 100 A)
Voltage protection level $U_p$ static (line-line)	$\leq 40 \text{ V}$ (C1 - 1 kV / 500 A) $\leq 95 \text{ V}$ (C2 - 10 kV / 5 kA)
Voltage protection level $U_p$ static (line-earth)	$\leq 750 \text{ V}$ (C1 - 1 kV / 500 A) $\leq 750 \text{ V}$ (C2 - 10 kV / 5 kA)
Response time $t_A$ (line-line)	$\leq 1 \text{ ns}$
Response time $t_A$ (line-earth)	$\leq 100 \text{ ns}$
Input attenuation aE, sym.	typ. 0.3 dB ( $\leq 8.7 \text{ MHz}/150 \Omega$ )
Input attenuation aE, asym.	typ. 0.3 dB ( $\leq 10.5 \text{ MHz}/150 \Omega$ )
Cut-off frequency $f_g$ (3 dB), sym. in 150 $\Omega$ system	typ. 60 MHz
Capacity (Core-Core)	typ. 32 pF
Resistance per path	1.65 $\Omega \pm 20 \%$
Surge protection fault message	optical
Max. required back-up fuse	630 mA (FF)
Impulse durability (line-line)	C1 - 1 kV / 500 A C2 - 10 kV / 5 kA C3 - 100 A
Impulse durability (line-earth)	C1 - 1 kV / 500 A C2 - 10 kV / 5 kA C3 - 100 A D1 - 500 A
Pulse reset time (line-line)	$\leq 30 \text{ ms}$

2906769

<https://www.phoenixcontact.com/us/products/2906769>

Pulse reset time (line-earth)	≤ 30 ms
-------------------------------	---------

#### Additional technical data

Max. total discharge current $I_{\text{total max}} (8/20) \mu\text{s}$	20 kA (1x)
--	------------

### Environmental and real-life conditions

#### Ambient conditions

Degree of protection	IP20
Ambient temperature (operation)	-40 °C ... 85 °C
Ambient temperature (storage/transport)	-40 °C ... 85 °C
Altitude	≤ 4000 m (amsl)
Permissible humidity (operation)	5 % ... 95 %

### Standards and regulations

Standards/specifications	IEC 61643-21
Note	2000 + corrigendum 2001 + A1:2008, modified + A2:2012

#### EN 61643-21

Standards/specifications	EN 61643-21
Note	2001 + A1:2009 + A2:2013

### Mounting

Mounting type	DIN rail: TH 35 - 7.5 mm
---------------	--------------------------

# TTC-6-3-HF-F-M-12DC-UT-I - Surge protection device



2906769

<https://www.phoenixcontact.com/us/products/2906769>

## Drawings

Dimensional drawing

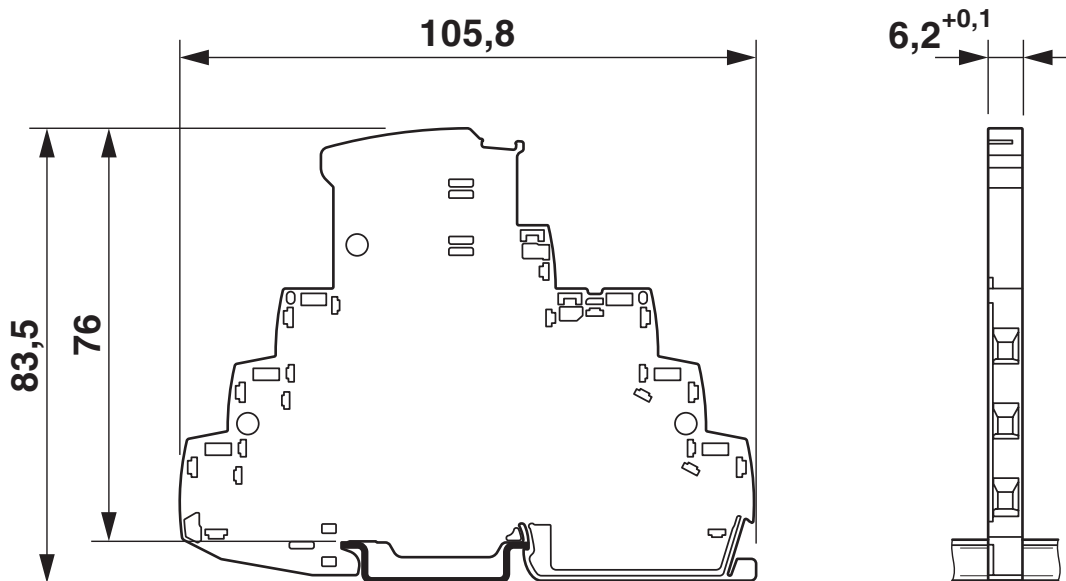

Schematic diagram

TTC-6-3-HF-F-M-...-I									
Category	1oo1 architecture, HFT=0				1oo2 architecture, HFT=1				
	PFD <sub>AVG</sub>	PFH	Used budget of SIL 2 SIF		PFD <sub>AVG</sub>	PFH	CCF	Used budget of SIL 3 SIF	
			PFD <sub>AVG</sub>	PFH				PFD <sub>AVG</sub>	PFH
	3.26x10 <sup>-5</sup>	5.80x10 <sup>-9</sup> 1/h	0.3 %	0.6 %	1.63x10 <sup>-6</sup>	2.90x10 <sup>-10</sup> 1/h	5 %	0.2 %	0.3 %
					3.26x10 <sup>-6</sup>	5.80x10 <sup>-10</sup> 1/h	10 %	0.3 %	0.6 %
Calculation based on exida report, Phoenix Contact 16/06-072 R023 V3R1 exida Profile 1, FMEDA Analysis 2, T <sub>proof</sub> : 1 year, MT: 10 years, MTTR: 24 hours, PTC: 99% Used standards IEC/EN 61508, edition 2010 (device specific) IEC/EN 61511, edition 2016 + COR1:2016 + A1:2017 (system specific)									

## Functional safety scenarios

Diagram



Circuit diagram

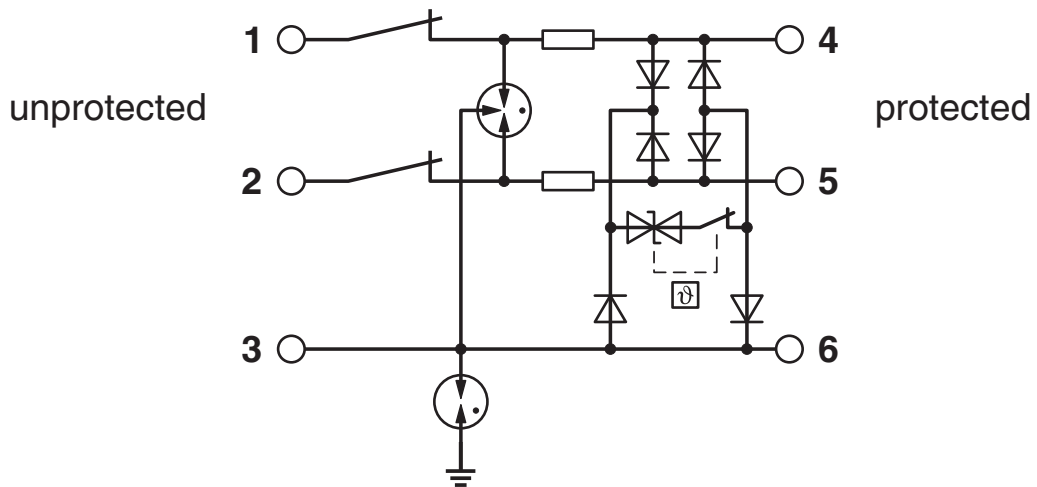

2906769

<https://www.phoenixcontact.com/us/products/2906769>

## Approvals

To download certificates, visit the product detail page: <https://www.phoenixcontact.com/us/products/2906769>



**CSA**

Approval ID: 70136717



**DNV GL**

Approval ID: TAE000027G



**UL Listed**

Approval ID: FILE E 138168



**CSAus**

Approval ID: 70136717

**UAE-RoHS**

Approval ID: 22-06-16191

**Functional Safety**

Approval ID: 16-06-072 R023 V3R1

2906769

<https://www.phoenixcontact.com/us/products/2906769>

## Classifications

### ECLASS

ECLASS-13.0	27171503
ECLASS-15.0	27171503

### ETIM

ETIM 10.0	EC001466
-----------	----------

### UNSPSC

UNSPSC 21.0	39121600
-------------	----------

2906769

<https://www.phoenixcontact.com/us/products/2906769>

## Environmental product compliance

### EU RoHS

Fulfills EU RoHS substance requirements	Yes
Exemption	7(a), 7(c)-I

### China RoHS

Environment friendly use period (EFUP)	EFUP-50
	An article-related China RoHS declaration table can be found in the download area for the respective article under "Manufacturer declaration". For all articles with EFUP-E, no China RoHS declaration table issued and required.

### EU REACH SVHC

REACH candidate substance (CAS No.)	Lead(CAS: 7439-92-1)
SCIP	79ab39b7-763e-4c86-870f-8a9ac115a443

### EF3.1 Climate Change

CO2e kg	1.596 kg CO2e
---------	---------------

Phoenix Contact 2026 © - all rights reserved  
<https://www.phoenixcontact.com>

Phoenix Contact USA  
 586 Fulling Mill Road  
 Middletown, PA 17057, United States  
 (+717) 944-1300  
[info@phoenixcon.com](mailto:info@phoenixcon.com)