

TTC-6-1X2-F-M-24DC-UT-I - Surge protection device



2906764

<https://www.phoenixcontact.com/us/products/2906764>

Please be informed that the data shown in this PDF document is generated from our online catalog. Please find the complete data in the user documentation. Our general terms of use for downloads are valid.



Surge protection with integrated status indicator and knife disconnection for a 2-wire floating signal circuit, e.g., 0(4) mA ... 20 mA current loop. Indirect grounding via gas discharge tube, HART-compatible. Can be used in safety-related circuits up to SIL 3.

Your advantages

- Space-saving and cost-saving with a narrow overall width of just 6 mm
- Continuous monitoring of protective devices, plus mechanical status indicator with optional remote signaling
- Finding the right product for all possible requirements in MCR applications is easy, thanks to the complete range of products with customized features
- Signal circuits easily interrupted for maintenance work, thanks to vertical knife disconnection

Commercial data

Item number	2906764
Packing unit	1 pc
Minimum order quantity	1 pc
Sales key	CL23
Product key	CL2261
GTIN	4055626135137
Weight per piece (including packing)	46 g
Weight per piece (excluding packing)	34 g
Customs tariff number	85363010
Country of origin	DE

TTC-6-1X2-F-M-24DC-UT-I - Surge protection device



2906764

<https://www.phoenixcontact.com/us/products/2906764>

Technical data

Product properties

Product type	Surge protection for MCR technology
Product family	TERMITRAB complete
IEC test classification	C1
	C2
	C3
	D1
Type	DIN rail module, one-piece
Wire pairs per module	1

Insulation characteristics

Overvoltage category	III
Pollution degree	2

Electrical properties

Nominal voltage U_N	24 V DC
-----------------------	---------

Connection data

Connection method	Screw connection
Screw thread	M3
Tightening torque	0.5 Nm ... 0.6 Nm
Conductor cross-section flexible	0.2 mm ² ... 2.5 mm ²
Conductor cross-section rigid	0.2 mm ² ... 4 mm ²
Conductor cross-section AWG	24 ... 12

Dimensions

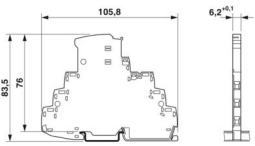
Dimensional drawing	
Width	6.2 mm +0.1 mm
Height	105.8 mm
Depth	83.5 mm (incl. DIN rail 7.5 mm)

Material specifications

Color	gray (RAL 7042)
	light gray (RAL 7035)
Flammability rating according to UL 94	V-0
Insulating material	PBT
Housing material	PBT

TTC-6-1X2-F-M-24DC-UT-I - Surge protection device



2906764

<https://www.phoenixcontact.com/us/products/2906764>

Mechanical properties

Mechanical data

Open side panel	No
-----------------	----

Protective circuit

Direction of action	Line-Line & Line-Signal Ground/Shield & optional Signal Ground/Shield-Earth Ground
Nominal voltage U_N	24 V DC
Maximum continuous operating voltage U_C	30 V DC 21 V AC
Rated current	600 mA (40 °C)
Operating effective current I_C at U_C	$\leq 5 \mu A$
Protective conductor current I_{PE}	$\leq 1 \mu A$
Nominal discharge current I_n (8/20) μs (line-line)	5 kA
Nominal discharge current I_n (8/20) μs (line-ground)	5 kA
Nominal discharge current I_n (8/20) μs (line-signal ground)	5 kA
Pulse discharge current I_{imp} (10/350) μs (line-line)	0.5 kA
Pulse discharge current I_{imp} (10/350) μs (line-earth)	0.5 kA
Pulse discharge current I_{imp} (10/350) μs (line-signal ground)	0.5 kA
Total discharge current I_{Total} (8/20) μs	10 kA
Voltage protection level U_p (line-line)	≤ 55 V (C1 - 1 kV / 500 A) ≤ 65 V (C2 - 10 kV / 5 kA) ≤ 50 V (C3 - 25 A) ≤ 55 V (C3 - 100 A)
Voltage protection level U_p (line-earth)	≤ 900 V (C1 - 1 kV / 500 A) ≤ 1.05 kV (C2 - 10 kV / 5 kA) ≤ 1.3 kV (C3 - 25 A) ≤ 1.4 kV (C3 - 100 A)
Voltage protection level U_p (line-signal ground)	≤ 750 V (C1 - 1 kV / 500 A) ≤ 750 V (C2 - 10 kV / 5 kA) ≤ 700 V (C3 - 25 A) ≤ 750 V (C3 - 100 A)
Voltage protection level U_p static (line-line)	≤ 50 V (C1 - 1 kV / 500 A) ≤ 65 V (C2 - 10 kV / 5 kA)
Voltage protection level U_p static (line-earth)	≤ 900 V (C1 - 1 kV / 500 A) ≤ 1.05 kV (C2 - 10 kV / 5 kA)
Voltage protection level U_p static (line-signal ground)	≤ 750 V (C1 - 1 kV / 500 A) ≤ 750 V (C2 - 10 kV / 5 kA)
Response time t_A (line-line)	≤ 1 ns
Response time t_A (line-earth)	≤ 100 ns
Response time t_A (line-signal ground)	≤ 100 ns
Input attenuation aE, sym.	typ. 0.3 dB (≤ 250 kHz / 150 Ω)
Cut-off frequency f_g (3 dB), sym. in 150 Ω system	typ. 940 kHz

TTC-6-1X2-F-M-24DC-UT-I - Surge protection device



2906764

<https://www.phoenixcontact.com/us/products/2906764>

Capacity (Core-Core)	typ. 2.2 nF
Resistance per path	1.65 Ω \pm 20 %
Surge protection fault message	optical
Max. required back-up fuse	630 mA (FF)
Impulse durability (line-line)	C1 - 1 kV / 500 A
	C2 - 10 kV / 5 kA
	C3 - 100 A
Impulse durability (line-earth)	C1 - 1 kV / 500 A
	C2 - 10 kV / 5 kA
	C3 - 100 A
	D1 - 500 A
Impulse durability (line-signal ground)	C1 - 1 kV / 500 A
	C2 - 10 kV / 5 kA
	C3 - 100 A
	D1 - 500 A
Pulse reset time (line-line)	\leq 700 ms
Pulse reset time (line-earth)	\leq 30 ms
Pulse reset time (line-signal ground)	\leq 1500 ms

Additional technical data

Max. total discharge current $I_{\text{total max}}$ (8/20) μ s	20 kA (1x)
--	------------

Environmental and real-life conditions

Ambient conditions

Degree of protection	IP20
Ambient temperature (operation)	-40 °C ... 85 °C
Ambient temperature (storage/transport)	-40 °C ... 85 °C
Altitude	\leq 4000 m (amsl)
Permissible humidity (operation)	5 % ... 95 %

Standards and regulations

Standards/specifications	IEC 61643-21
Note	2000 + corrigendum 2001 + A1:2008, modified + A2:2012

EN 61643-21

Standards/specifications	EN 61643-21
Note	2001 + A1:2009 + A2:2013

Mounting

Mounting type	DIN rail: TH 35 - 7.5 mm
---------------	--------------------------

TTC-6-1X2-F-M-24DC-UT-I - Surge protection device



2906764

<https://www.phoenixcontact.com/us/products/2906764>

Drawings

Dimensional drawing

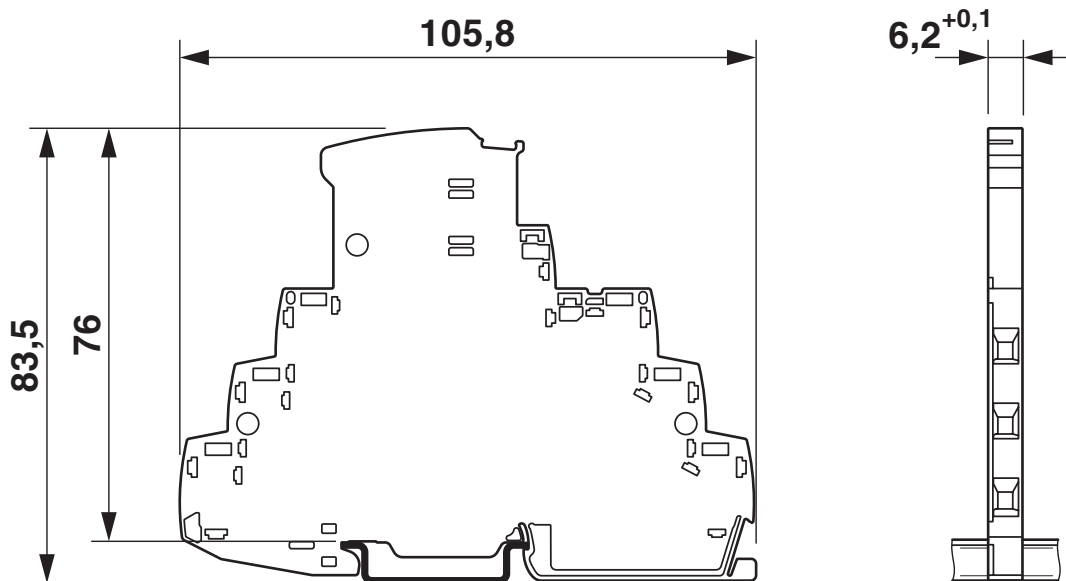

Schematic diagram

TTC-6-1X2-F-M-...-I									
Category	1oo1 architecture, HFT=0				1oo2 architecture, HFT=1				
	PFD _{AVG}	PFH	Used budget of SIL 2 SIF		PFD _{AVG}	PFH	CCF	Used budget of SIL 3 SIF	
			PFD _{AVG}	PFH				PFD _{AVG}	PFH
	2.70 $\cdot 10^{-5}$	4.80 $\cdot 10^{-9}$ 1/h	0.3 %	0.5 %	1.35 $\cdot 10^{-6}$	2.40 $\cdot 10^{-10}$ 1/h	5 %	0.1 %	0.2 %
					2.70 $\cdot 10^{-6}$	4.80 $\cdot 10^{-10}$ 1/h	10 %	0.3 %	0.5 %
Calculation based on exida report, Phoenix Contact 16/06-072 R023 V3R1 exida Profile 1, FMEDA Analysis 2, T _{proof} : 1 year, MT: 10 years, MTTR: 24 hours, PTC: 99% Used standards IEC/EN 61508, edition 2010 (device specific) IEC/EN 61511, edition 2016 + COR1:2016 + A1:2017 (system specific)									

Functional safety scenarios

Diagram

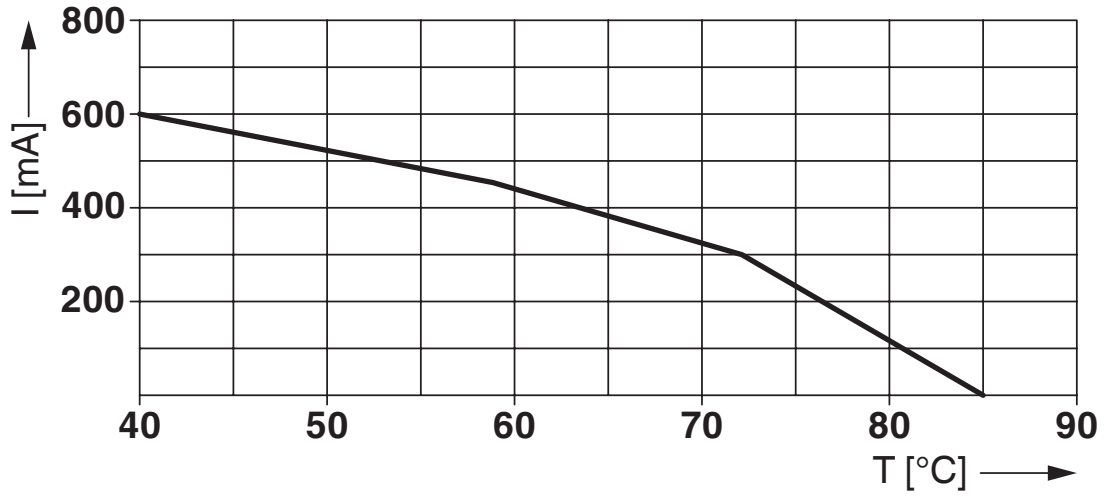

Circuit diagram

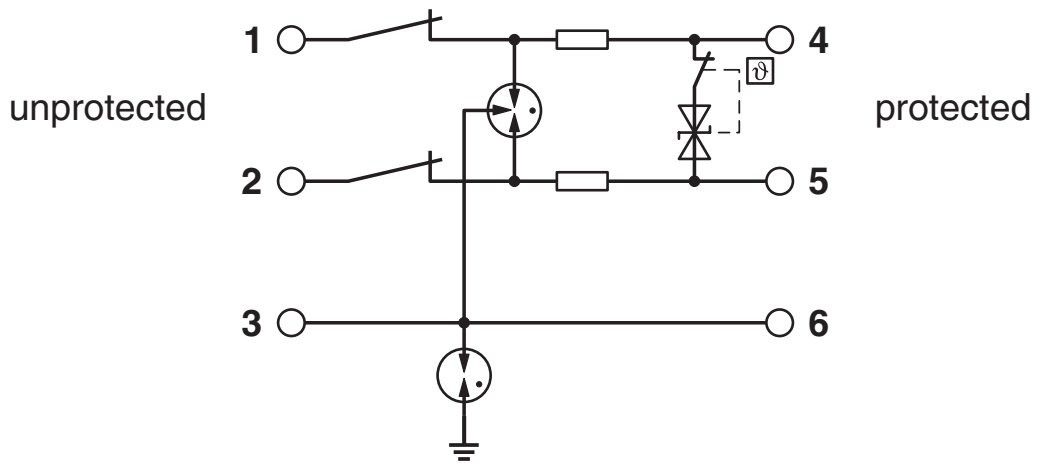

2906764

<https://www.phoenixcontact.com/us/products/2906764>

Approvals

To download certificates, visit the product detail page: <https://www.phoenixcontact.com/us/products/2906764>

 **CSA**
Approval ID: 70136717

 **DNV GL**
Approval ID: TAE000027G

 **UL Listed**
Approval ID: FILE E 138168

 **CSAus**
Approval ID: 70136717

UAE-RoHS
Approval ID: 22-06-16191

Functional Safety
Approval ID: 16-06-072 R023 V3R1

TTC-6-1X2-F-M-24DC-UT-I - Surge protection device



2906764

<https://www.phoenixcontact.com/us/products/2906764>

Classifications

ECLASS

ECLASS-13.0	27171501
ECLASS-15.0	27171501

ETIM

ETIM 10.0	EC001466
-----------	----------

UNSPSC

UNSPSC 21.0	39121600
-------------	----------

2906764

<https://www.phoenixcontact.com/us/products/2906764>

Environmental product compliance

EU RoHS

Fulfills EU RoHS substance requirements	Yes
Exemption	7(a), 7(c)-I

China RoHS

Environment friendly use period (EFUP)	EFUP-50
	An article-related China RoHS declaration table can be found in the download area for the respective article under "Manufacturer declaration". For all articles with EFUP-E, no China RoHS declaration table issued and required.

EU REACH SVHC

REACH candidate substance (CAS No.)	Lead(CAS: 7439-92-1)
SCIP	a1abaa39-8c69-47f9-9423-5d185e6c2f5d

Phoenix Contact 2026 © - all rights reserved

<https://www.phoenixcontact.com>

Phoenix Contact USA
586 Fulling Mill Road
Middletown, PA 17057, United States
(+717) 944-1300
info@phoenixcon.com