

TTC-6-3-HF-M-12DC-UT-I - Surge protection device



2906721

<https://www.phoenixcontact.com/us/products/2906721>

Please be informed that the data shown in this PDF document is generated from our online catalog. Please find the complete data in the user documentation. Our general terms of use for downloads are valid.



Surge protection with integrated status indicator and knife disconnection for three signal wires with common reference potential. For HF applications and telecommunications interfaces without supply voltage (up to 90 Mbps). Can be used in safety-related circuits up to SIL 3.

Your advantages

- Space-saving and cost-saving with a narrow overall width of just 6 mm
- Continuous monitoring of protective devices, plus mechanical status indicator with optional remote signaling
- Finding the right product for all possible requirements in MCR applications is easy, thanks to the complete range of products with customized features
- Signal circuits easily interrupted for maintenance work, thanks to vertical knife disconnection

Commercial data

Item number	2906721
Packing unit	1 pc
Minimum order quantity	1 pc
Sales key	CL23
Product key	CL2261
GTIN	4055626134529
Weight per piece (including packing)	42.7 g
Weight per piece (excluding packing)	33.07 g
Customs tariff number	85363010
Country of origin	DE

Technical data

Product properties

Product type	Surge protection for information technology
Product family	TERMITRAB complete
IEC test classification	C1
	C2
	C3
	D1
Type	DIN rail module, one-piece

Insulation characteristics

Overvoltage category	III
Pollution degree	2

Electrical properties

Nominal voltage U_N	12 V DC
-----------------------	---------

Connection data

Connection method	Screw connection
Screw thread	M3
Tightening torque	0.5 Nm ... 0.6 Nm
Conductor cross-section flexible	0.2 mm ² ... 2.5 mm ²
Conductor cross-section rigid	0.2 mm ² ... 4 mm ²
Conductor cross-section AWG	24 ... 12

Dimensions

Dimensional drawing	
Width	6.2 mm +0.1 mm
Height	105.8 mm
Depth	83.5 mm (incl. DIN rail 7.5 mm)

Material specifications

Color	gray (RAL 7042)
Flammability rating according to UL 94	V-0
Insulating material	PBT
Housing material	PBT

Mechanical properties

TTC-6-3-HF-M-12DC-UT-I - Surge protection device



2906721

<https://www.phoenixcontact.com/us/products/2906721>

Mechanical data

Open side panel	No
-----------------	----

Protective circuit

Direction of action	Line-Line & Line-Signal Ground/Shield & optional Signal Ground/Shield-Earth Ground
Nominal voltage U_N	12 V DC
Maximum continuous operating voltage U_C	15 V DC 10 V AC
Rated current	600 mA (40 °C)
Operating effective current I_C at U_C	$\leq 100 \mu\text{A}$
Protective conductor current I_{PE}	$\leq 200 \mu\text{A}$
Nominal discharge current I_n (8/20) μs (line-line)	5 kA
Nominal discharge current I_n (8/20) μs (line-ground)	5 kA
Pulse discharge current I_{imp} (10/350) μs (line-earth)	0.5 kA
Total discharge current I_{Total} (8/20) μs	10 kA
Voltage protection level U_p (line-line)	$\leq 145 \text{ V}$ (C1 - 1 kV / 500 A) $\leq 120 \text{ V}$ (C2 - 10 kV / 5 kA) $\leq 25 \text{ V}$ (C3 - 25 A) $\leq 30 \text{ V}$ (C3 - 100 A)
Voltage protection level U_p (line-earth)	$\leq 80 \text{ V}$ (C1 - 1 kV / 500 A) $\leq 80 \text{ V}$ (C2 - 10 kV / 5 kA) $\leq 25 \text{ V}$ (C3 - 25 A) $\leq 30 \text{ V}$ (C3 - 100 A)
Voltage protection level U_p static (line-line)	$\leq 40 \text{ V}$ (C1 - 1 kV / 500 A) $\leq 95 \text{ V}$ (C2 - 10 kV / 5 kA)
Voltage protection level U_p static (line-earth)	$\leq 40 \text{ V}$ (C1 - 1 kV / 500 A) $\leq 95 \text{ V}$ (C2 - 10 kV / 5 kA)
Response time t_A (line-line)	$\leq 1 \text{ ns}$
Response time t_A (line-earth)	$\leq 1 \text{ ns}$
Input attenuation aE, sym.	typ. 0.3 dB ($\leq 8.7 \text{ MHz}/150 \Omega$)
Input attenuation aE, asym.	typ. 0.3 dB ($\leq 10.5 \text{ MHz}/150 \Omega$)
Cut-off frequency f_g (3 dB), sym. in 150 Ω system	typ. 60 MHz
Cut-off frequency f_g (3 dB), asym. (PE) in 150 Ω system	typ. 60 MHz
Capacity (Core-Core)	typ. 32 pF
Capacity (Core-Earth)	typ. 32 pF
Resistance per path	1.65 $\Omega \pm 20 \%$
Surge protection fault message	optical
Max. required back-up fuse	630 mA (FF)
Impulse durability (line-line)	C1 - 1 kV / 500 A C2 - 10 kV / 5 kA C3 - 100 A
Impulse durability (line-earth)	C1 - 1 kV / 500 A C2 - 10 kV / 5 kA

TTC-6-3-HF-M-12DC-UT-I - Surge protection device



2906721

<https://www.phoenixcontact.com/us/products/2906721>

	C3 - 100 A
	D1 - 500 A
Pulse reset time (line-line)	≤ 30 ms
Pulse reset time (line-earth)	≤ 30 ms

Additional technical data

Max. total discharge current $I_{\text{total max}} (8/20) \mu\text{s}$	20 kA (1x)
--	------------

Environmental and real-life conditions

Ambient conditions

Degree of protection	IP20
Ambient temperature (operation)	-40 °C ... 85 °C
Ambient temperature (storage/transport)	-40 °C ... 85 °C
Altitude	≤ 4000 m (amsl)
Permissible humidity (operation)	5 % ... 95 %

Standards and regulations

Standards/specifications	IEC 61643-21
Note	2000 + corrigendum 2001 + A1:2008, modified + A2:2012

EN 61643-21

Standards/specifications	EN 61643-21
Note	2001 + A1:2009 + A2:2013

Mounting

Mounting type	DIN rail: TH 35 - 7.5 mm
---------------	--------------------------

TTC-6-3-HF-M-12DC-UT-I - Surge protection device



2906721

<https://www.phoenixcontact.com/us/products/2906721>

Drawings

Dimensional drawing

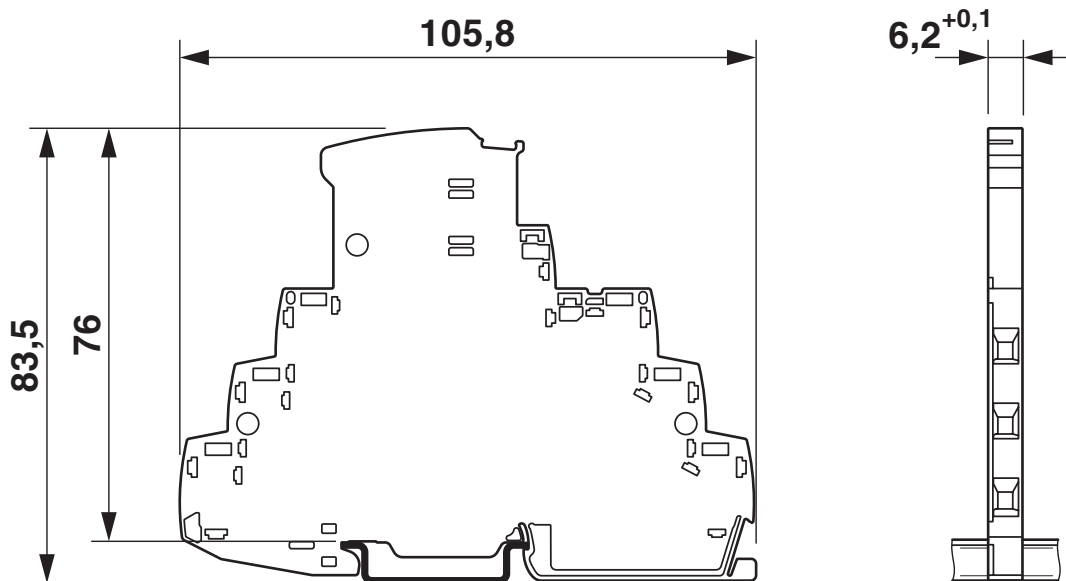

Schematic diagram

TTC-6-3-HF-M-...-I									
Category	1001 architecture, HFT=0				1002 architecture, HFT=1				
	PFD _{AVG}	PFH	Used budget of SIL 2 SIF		PFD _{AVG}	PFH	CCF	Used budget of SIL 3 SIF	
			PFD _{AVG}	PFH				PFD _{AVG}	PFH
	1.21x10 ⁻⁵	2.16x10 ⁻⁸ 1/h	1.2 %	2.2 %	6.09x10 ⁻⁶	1.08x10 ⁻⁹ 1/h	5 %	0.6 %	1.1 %
					1.22x10 ⁻⁵	2.16x10 ⁻⁹ 1/h	10 %	1.2 %	2.2 %
Calculation based on exida report, Phoenix Contact 16/06-072 R023 V3R1 exida Profile 1, FMEDA Analysis 2, T _{proof} : 1 year, MT: 10 years, MTTR: 24 hours, PTC: 99% Used standards IEC/EN 61508, edition 2010 (device specific) IEC/EN 61511, edition 2016 + COR1:2016 + A1:2017 (system specific)									

Functional safety scenarios

Diagram

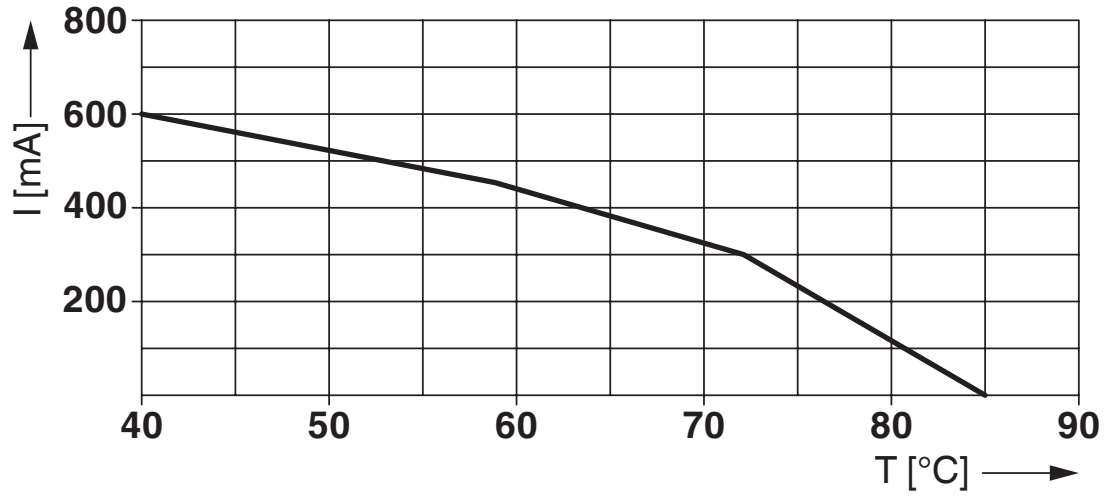

Circuit diagram

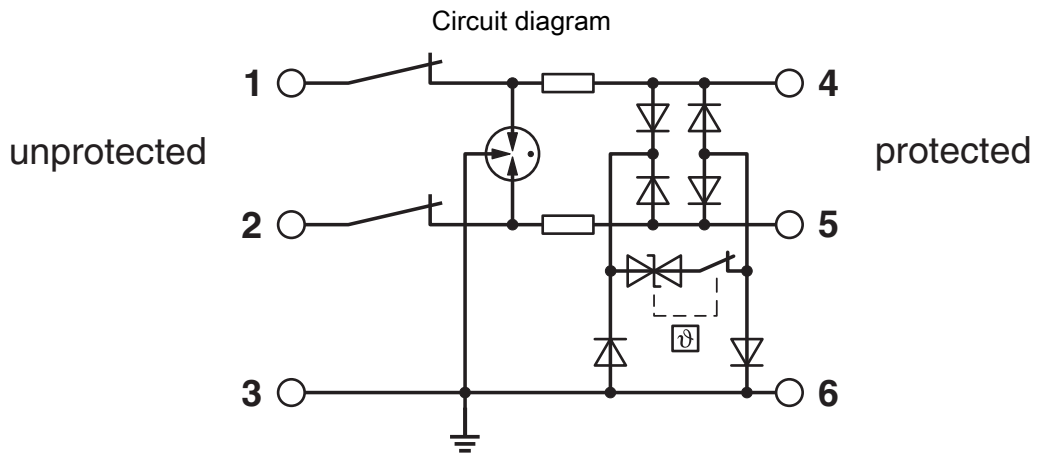

2906721

<https://www.phoenixcontact.com/us/products/2906721>

Approvals

To download certificates, visit the product detail page: <https://www.phoenixcontact.com/us/products/2906721>

 **CSA**
Approval ID: 70136717

 **DNV GL**
Approval ID: TAE000027G

 **UL Listed**
Approval ID: FILE E 138168

 **CSAus**
Approval ID: 70136717

UAE-RoHS
Approval ID: 22-06-16191

Functional Safety
Approval ID: 16-06-072 R023 V3R1

TTC-6-3-HF-M-12DC-UT-I - Surge protection device



2906721

<https://www.phoenixcontact.com/us/products/2906721>

Classifications

ECLASS

ECLASS-13.0	27171503
ECLASS-15.0	27171503

ETIM

ETIM 10.0	EC001466
-----------	----------

UNSPSC

UNSPSC 21.0	39121600
-------------	----------

2906721

<https://www.phoenixcontact.com/us/products/2906721>

Environmental product compliance

EU RoHS

Fulfills EU RoHS substance requirements	Yes
Exemption	7(a), 7(c)-I

China RoHS

Environment friendly use period (EFUP)	EFUP-50
	An article-related China RoHS declaration table can be found in the download area for the respective article under "Manufacturer declaration". For all articles with EFUP-E, no China RoHS declaration table issued and required.

EU REACH SVHC

REACH candidate substance (CAS No.)	Lead(CAS: 7439-92-1)
SCIP	f25cbcb0-8639-4251-b879-fddfbbf3555e

EF3.1 Climate Change

CO2e kg	1.28 kg CO2e
---------	--------------

Phoenix Contact 2026 © - all rights reserved
<https://www.phoenixcontact.com>

Phoenix Contact USA
 586 Fulling Mill Road
 Middletown, PA 17057, United States
 (+717) 944-1300
info@phoenixcon.com