

MACX MCR-VAC - Voltage measuring transducers



2906239

<https://www.phoenixcontact.com/us/products/2906239>

Please be informed that the data shown in this PDF document is generated from our online catalog. Please find the complete data in the user documentation. Our general terms of use for downloads are valid.



MACX MCR voltage transducer, for AC voltages from 0 V ... 20 V AC to 0 ... 660 V AC, output signal: 0 V ... 10 V/0(4) ... 20 mA

Your advantages

- Adjustable voltage ranges
- Bidirectional output signals
- 3-way isolation
- ZERO/SPAN adjustment $\pm 20\%$
- Tool-free parameterization of measured values
- Teach-in configuration of the measured value range

Commercial data

Item number	2906239
Packing unit	1 pc
Minimum order quantity	1 pc
Sales key	C445
Product key	CMMB11
GTIN	4055626051000
Weight per piece (including packing)	156.6 g
Weight per piece (excluding packing)	211 g
Customs tariff number	85437090
Country of origin	DE

Technical data

Product properties

Product type	Voltage transducer
--------------	--------------------

Electrical properties

Alignment span	± 20 %
Alignment zero	± 20 %
Protective circuit	Surge protection; 33 V suppressor diode
Step response (10-90%)	< 180 ms
Maximum temperature coefficient	< 0.015 %/K
Maximum transmission error	< 1 % (from a measuring range final value, 15 Hz ... 65 Hz)
	< 1.3 % (from a measuring range final value, 65 Hz ... 405 Hz)

Electrical isolation

Pollution degree	2
------------------	---

Electrical isolation Measuring circuit to supply circuit and output IEC 61010-2-030

Standards/regulations	IEC 61010-2-030
Test voltage	5.3 kV AC (50 Hz, 60 s)
Measuring category	II (1000 V)
	III (600 V)
	IV (300 V)
Insulation	Reinforced insulation

Electrical isolation Supply circuit to output circuit IEC 61010-1

Standards/regulations	IEC 61010-1
Test voltage	2.2 kV AC (50 Hz, 60 s)
Overvoltage category	III (300 V)
	IV (150 V)
Insulation	Basic insulation

Supply

Nominal supply voltage	24 V DC (-20 % ... +25 %)
Supply voltage range	19.2 V DC ... 30 V DC
Max. current consumption	< 45 mA

Input data

Measurement

Configurable/programmable	Yes
Input voltage range	0 V AC ... 550 V AC
Maximum input voltage	+ 660 V AC
Frequency range	15 Hz ... 405 Hz
Input resistance of voltage input	5500 kΩ
Impulse form	AC voltage

MACX MCR-VAC - Voltage measuring transducers



2906239

<https://www.phoenixcontact.com/us/products/2906239>

Measurement

Input voltage range	0 V AC ... 370 V AC
Input resistance of voltage input	3700 k Ω

Measurement

Input voltage range	0 V AC ... 250 V AC
Input resistance of voltage input	2500 k Ω

Measurement

Input voltage range	0 V AC ... 170 V AC
Input resistance of voltage input	1700 k Ω

Measurement

Input voltage range	0 V AC ... 120 V AC
Input resistance of voltage input	1200 k Ω

Measurement

Input voltage range	0 V AC ... 80 V AC
Input resistance of voltage input	800 k Ω

Measurement

Input voltage range	0 V AC ... 54 V AC
Input resistance of voltage input	800 k Ω

Measurement

Input voltage range	0 V AC ... 36 V AC
Input resistance of voltage input	800 k Ω

Measurement

Input voltage range	0 V AC ... 24 V AC
Input resistance of voltage input	240 k Ω

Output data

Signal: Voltage

Voltage output signal	0 V ... 10 V
	2 V ... 10 V
Max. voltage output signal	\leq 11 V
Load/output load voltage output	$>$ 10 k Ω
Ripple	50 mV

Signal: Current

Current output signal	0 mA ... 20 mA
	4 mA ... 20 mA
Max. current output signal	\leq 22 mA
Load/output load current output	$<$ 500 Ω
Max. capacitive load	$<$ 1000 pF
Max. inductive load	$<$ 1 mH

MACX MCR-VAC - Voltage measuring transducers



2906239

<https://www.phoenixcontact.com/us/products/2906239>

Connection data

Connection method	Screw connection
Stripping length	8 mm
Screw thread	M3
Conductor cross-section rigid	0.2 mm ² ... 2.5 mm ²
Conductor cross-section flexible	0.2 mm ² ... 2.5 mm ²
Conductor cross-section AWG	24 ... 14

Dimensions

Width	22.5 mm
Height	113 mm
Depth	114 mm

Material specifications

Color	gray (RAL 7042)
-------	-----------------

Environmental and real-life conditions

Ambient conditions

Degree of protection	IP20
Ambient temperature (operation)	-25 °C ... 60 °C
Ambient temperature (storage/transport)	-40 °C ... 85 °C (non-condensing)
Altitude	≤ 2000 m
Permissible humidity (operation)	10 % ... 95 % (non-condensing)

Approvals

CE

Certificate	CE-compliant
-------------	--------------

UL, USA/Canada

Identification	UL 61010 Listed
----------------	-----------------

EMC data

Electromagnetic compatibility	Conformance with EMC directive
Low Voltage Directive	Conformance with Low Voltage Directive
Noise immunity	EN 61000-6-2
Note	When being exposed to interference, there may be minimal deviations.

Noise emission

Standards/regulations	EN 61000-6-4
-----------------------	--------------

Mounting

Mounting type	DIN rail mounting
Assembly note	can be aligned with spacing = 10 mm

MACX MCR-VAC - Voltage measuring transducers



2906239

<https://www.phoenixcontact.com/us/products/2906239>

Mounting position	any
-------------------	-----

MACX MCR-VAC - Voltage measuring transducers



2906239

<https://www.phoenixcontact.com/us/products/2906239>

Drawings

Block diagram

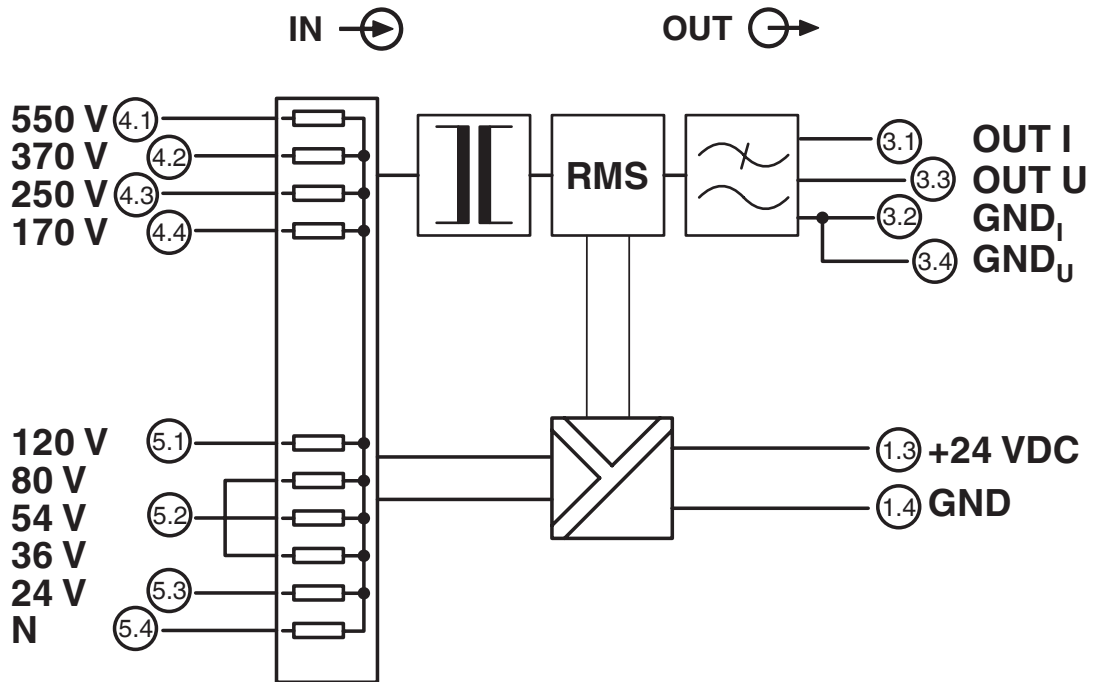

MACX MCR-VAC - Voltage measuring transducers



2906239

<https://www.phoenixcontact.com/us/products/2906239>

Approvals

To download certificates, visit the product detail page: <https://www.phoenixcontact.com/us/products/2906239>



UL Listed

Approval ID: E330267



cUL Listed

Approval ID: FILE E 330267

MACX MCR-VAC - Voltage measuring transducers



2906239

<https://www.phoenixcontact.com/us/products/2906239>

Classifications

ECLASS

ECLASS-13.0	27210125
ECLASS-15.0	27210125

ETIM

ETIM 10.0	EC002477
-----------	----------

UNSPSC

UNSPSC 21.0	39121000
-------------	----------

2906239

<https://www.phoenixcontact.com/us/products/2906239>

Environmental product compliance

EU RoHS

Fulfills EU RoHS substance requirements	Yes
Exemption	7(a), 7(c)-I

China RoHS

Environment friendly use period (EFUP)	EFUP-50
	An article-related China RoHS declaration table can be found in the download area for the respective article under "Manufacturer declaration". For all articles with EFUP-E, no China RoHS declaration table issued and required.

EU REACH SVHC

REACH candidate substance (CAS No.)	Lead(CAS: 7439-92-1)
	2,2',6,6'-tetrabromo-4,4'-isopropylidenediphenol(CAS: 79-94-7)
SCIP	6aea0446-e6e3-4321-a23f-333cd1eddf81

Phoenix Contact 2026 © - all rights reserved
<https://www.phoenixcontact.com>

Phoenix Contact USA
586 Fulling Mill Road
Middletown, PA 17057, United States
(+717) 944-1300
info@phoenixcon.com