

# PT 5-HF-24DC-ST - Surge protection device



2906002

<https://www.phoenixcontact.com/us/products/2906002>

Please be informed that the data shown in this PDF document is generated from our online catalog. Please find the complete data in the user documentation. Our general terms of use for downloads are valid.



PT protective plug with HF protective circuit for 4 signal wires. Nominal voltage: 24 V DC

## Your advantages

- Easy testing and documentation with CHECKMASTER 2 with pluggable protective modules
- Maximum ease of maintenance, thanks to the 2-piece design
- Easy selection for all possible demands in MCR applications with a complete product portfolio
- The signal is not influenced during maintenance work, thanks to the impedance-neutral insertion and removal of protective plugs

## Commercial data

Item number	2906002
Packing unit	1 pc
Minimum order quantity	1 pc
Sales key	CL03
Product key	CL3121
GTIN	4055626013398
Weight per piece (including packing)	35.5 g
Weight per piece (excluding packing)	22.05 g
Customs tariff number	85363010
Country of origin	DE

# PT 5-HF-24DC-ST - Surge protection device



2906002

<https://www.phoenixcontact.com/us/products/2906002>

## Technical data

### Product properties

Product type	Surge protection for information technology
Product family	PLUGTRAB PT
IEC test classification	C1
	C2
	C3
	D1
Type	Male
Number of positions	5
Wire pairs per module	2

### Insulation characteristics

Overvoltage category	III
Pollution degree	2

### Electrical properties

Nominal voltage $U_N$	24 V DC
-----------------------	---------

### Connection data

Connection method	Screw connection (in connection with the base element)
Screw thread	M3
Tightening torque	0.8 Nm
Conductor cross-section flexible	0.2 mm <sup>2</sup> ... 2.5 mm <sup>2</sup>
Conductor cross-section rigid	0.2 mm <sup>2</sup> ... 4 mm <sup>2</sup>
Conductor cross-section AWG	24 ... 12

### Dimensions

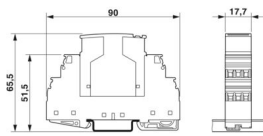
Dimensional drawing	
Width	17.7 mm
Height	45 mm
Depth	52 mm
Horizontal pitch	1 Div.

### Material specifications

Color	black (RAL 9005)
Flammability rating according to UL 94	V-0
Housing material	PA 6.6

# PT 5-HF-24DC-ST - Surge protection device



2906002

<https://www.phoenixcontact.com/us/products/2906002>

## Mechanical properties

### Mechanical data

Open side panel	No
-----------------	----

### Protective circuit

Direction of action	Line-Line & Line-Signal Ground/Shield & optional Signal Ground/Shield-Earth Ground
Nominal voltage $U_N$	24 V DC
Maximum continuous operating voltage $U_C$	28 V DC
Rated current	450 mA (45 °C)
Operating effective current $I_C$ at $U_C$	$\leq 5 \mu\text{A}$
Protective conductor current $I_{PE}$	$\leq 5 \mu\text{A}$ (with PT 2X2-BE)
	$\leq 1 \mu\text{A}$ (with PT 2X2+F-BE)
Nominal discharge current $I_n$ (8/20) $\mu\text{s}$ (line-line)	10 kA
Nominal discharge current $I_n$ (8/20) $\mu\text{s}$ (line-ground)	10 kA (with PT 2X2+F-BE)
	10 kA (with PT 2X2-BE)
Pulse discharge current $I_{imp}$ (10/350) $\mu\text{s}$	2.5 kA (with PT 2X2-BE)
	2.5 kA (with PT 2X2+F-BE)
Total discharge current $I_{Total}$ (8/20) $\mu\text{s}$	20 kA
Nominal pulse current $I_{an}$ (10/1000) $\mu\text{s}$ (line-line)	25 A
Voltage protection level $U_p$ (line-line)	$\leq 150 \text{ V}$ (C1 - 1 kV / 500 A)
	$\leq 165 \text{ V}$ (C2 - 10 kV / 5 kA)
	$\leq 450 \text{ V}$ (C2 - 10 kA)
	$\leq 50 \text{ V}$ (C3 - 25 A)
Voltage protection level $U_p$ (line-earth)	$\leq 150 \text{ V}$ (C1 - 1 kV / 500 A)
	$\leq 700 \text{ V}$ (C1 - 1 kV / 500 A with PT 2X2+F-BE)
	$\leq 165 \text{ V}$ (C2 - 10 kV / 5 kA)
	$\leq 900 \text{ V}$ (C2 - 10 kV / 5 kA with PT 2X2+F-BE)
	$\leq 450 \text{ V}$ (C2 - 10 kA)
	$\leq 1000 \text{ V}$ (C2 - 10 kA with PT 2X2+F-BE)
	$\leq 50 \text{ V}$ (C3 - 25 A)
Voltage protection level $U_p$ (line-signal ground)	$\leq 150 \text{ V}$ (C1 - 1 kV / 500 A)
	$\leq 150 \text{ V}$ (C1 - 1 kV / 500 A with PT 2X2+F-BE)
	$\leq 165 \text{ V}$ (C2 - 10 kV / 5 kA)
	$\leq 165 \text{ V}$ (C2 - 10 kV / 5 kA with PT 2X2-BE)
	$\leq 450 \text{ V}$ (C2 - 10 kA)
	$\leq 450 \text{ V}$ (C2 - 10 kV / 5 kA with PT 2X2-BE)
	$\leq 50 \text{ V}$ (C3 - 25 A)
	$\leq 50 \text{ V}$ (C3 - 25 A with PT 2X2-BE)
Response time $t_A$ (line-line)	$\leq 500 \text{ ns}$
Response time $t_A$ (line-earth)	$\leq 500 \text{ ns}$
Input attenuation aE, sym.	typ. 0.3 dB ( $\leq 13 \text{ MHz}$ / 100 $\Omega$ )

# PT 5-HF-24DC-ST - Surge protection device



2906002

<https://www.phoenixcontact.com/us/products/2906002>

Cut-off frequency $f_g$ (3 dB), sym. in 100 $\Omega$ system	typ. 70 MHz
Capacity (Core-Core)	typ. 23 pF
Resistance per path	2.2 $\Omega$ $\pm$ 10 %
Surge protection fault message	none
Max. required back-up fuse	500 mA (T)

## Environmental and real-life conditions

### Ambient conditions

Degree of protection	IP20
Ambient temperature (operation)	-40 °C ... 85 °C
Ambient temperature (storage/transport)	-40 °C ... 85 °C
Altitude	$\leq$ 2000 m (amsl)

## Standards and regulations

Standards/specifications	EN 61643-21/A2
Note	2013
Standards/specifications	IEC 61643-21/A2
Note	2012

## Mounting

Mounting type	on base element
---------------	-----------------

# PT 5-HF-24DC-ST - Surge protection device

2906002

<https://www.phoenixcontact.com/us/products/2906002>

## Drawings

Dimensional drawing



The figure shows the complete module consisting of a base element and connector

Circuit diagram

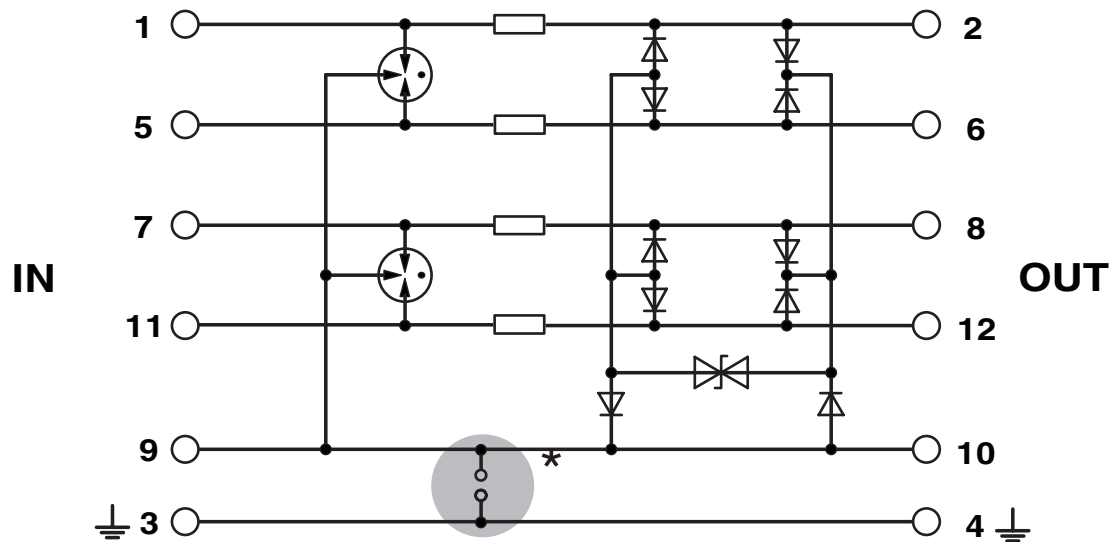

# PT 5-HF-24DC-ST - Surge protection device



2906002

<https://www.phoenixcontact.com/us/products/2906002>

## Classifications

### ECLASS

ECLASS-13.0	27171503
ECLASS-15.0	27171503

### ETIM

ETIM 10.0	EC001466
-----------	----------

### UNSPSC

UNSPSC 21.0	39121600
-------------	----------

# PT 5-HF-24DC-ST - Surge protection device



2906002

<https://www.phoenixcontact.com/us/products/2906002>

## Environmental product compliance

### EU RoHS

Fulfills EU RoHS substance requirements	Yes
Exemption	7(a), 7(c)-I

### China RoHS

Environment friendly use period (EFUP)	EFUP-50
	An article-related China RoHS declaration table can be found in the download area for the respective article under "Manufacturer declaration". For all articles with EFUP-E, no China RoHS declaration table issued and required.

### EU REACH SVHC

REACH candidate substance (CAS No.)	Lead(CAS: 7439-92-1)
SCIP	aee37143-61f4-4454-bad8-06e456adba78

### EF3.1 Climate Change

CO2e kg	42.144 kg CO2e
---------	----------------

Phoenix Contact 2026 © - all rights reserved  
<https://www.phoenixcontact.com>

Phoenix Contact USA  
586 Fulling Mill Road  
Middletown, PA 17057, United States  
(+717) 944-1300  
[info@phoenixcon.com](mailto:info@phoenixcon.com)