

# ELR H5-I-PT/500AC-3-IFS - Hybrid motor starter



2905146

<https://www.phoenixcontact.com/us/products/2905146>

Please be informed that the data shown in this PDF document is generated from our online catalog. Please find the complete data in the user documentation. Our general terms of use for downloads are valid.



Networkable hybrid motor starter for reversing 3~ AC motors up to 500 V AC, output current: 3 A, adjustable overload shutdown, and Push-in connection, DIN rail connector provided.

## Your advantages

- 22.5 mm wide
- Reduction in wiring
- Space saving
- Long service life
- 3-phase loop bridges
- Adjustable current for bimetal function
- Low-wear switching

## Commercial data

Item number	2905146
Packing unit	1 pc
Sales key	C474
Product key	DK7442
GTIN	4046356919555
Weight per piece (including packing)	298.3 g
Weight per piece (excluding packing)	285.7 g
Customs tariff number	85371098
Country of origin	DE

# ELR H5-I-PT/500AC-3-IFS - Hybrid motor starter



2905146

<https://www.phoenixcontact.com/us/products/2905146>

## Technical data

### Product properties

Product type	Hybrid motor starters
Product family	CONTACTRON
Operating mode	100% operating factor

### Electrical properties

Number of phases	3
Motor starter type	Reversing starter
Switching frequency	≤ 2 Hz (Load-dependent)
Maximum power dissipation for nominal condition	2.5 W
Switching frequency	≤ 2 Hz (Load-dependent)
Maximum power dissipation	4.1 W
Minimum power dissipation	0.88 W
Coordination type	1

### Supply

Rated control circuit supply voltage $U_S$	24 V DC
Control supply voltage range	19.2 V DC ... 30 V DC
Rated control supply current $I_S$	60 mA
Protective circuit	Surge protection Reverse polarity protection; Parallel polarity protection diode

### Insulation characteristics

Rated insulation voltage	550 V
Rated surge voltage	6 kV
Overvoltage category	III
Degree of pollution	2
Insulation characteristics between the control input and control supply voltage, and auxiliary circuit to the main circuit	Safe isolation (IEC 60947-1)
Isolation characteristics between the control input and control supply voltage to auxiliary circuit	Safe isolation (IEC 60947-1) in the auxiliary circuit ≤ 300 V AC

### Emergency tripping

Operate threshold	> 33 A
Response time	< 0.5 s

## Output data

### AC output

Rated operating voltage $U_e$	500 V AC
Operating voltage range	42 V AC ... 550 V AC
Rated operating current $I_e$	3 A (AC-51) 3 A (AC-53a)
Mains frequency	50/60 Hz

# ELR H5-I-PT/500AC-3-IFS - Hybrid motor starter



2905146

<https://www.phoenixcontact.com/us/products/2905146>

Load current range	180 mA ... 3 A (see to derating)
Trigger characteristic in acc. with IEC 60947-4-2	Class 10
Cooling time	20 min (for auto reset)
Leakage current	0 mA
Protective circuit	Surge protection; Varistor

## Connection data

### Control circuits

Connection method	Push-in connection
Stripping length	10 mm
Conductor cross-section rigid	0.2 mm <sup>2</sup> ... 2.5 mm <sup>2</sup>
Conductor cross-section flexible	0.2 mm <sup>2</sup> ... 2.5 mm <sup>2</sup>
Conductor cross-section AWG	24 ... 14

### Load circuit

Connection method	Push-in connection
Stripping length	10 mm
Conductor cross-section rigid	0.2 mm <sup>2</sup> ... 2.5 mm <sup>2</sup>
Conductor cross-section flexible	0.2 mm <sup>2</sup> ... 2.5 mm <sup>2</sup>
Conductor cross-section AWG	24 ... 14

## Signaling

Status display	LED (yellow)
Operating voltage display	Green LED
Error indication	Red LED

## Dimensions

Width	22.5 mm
Height	107.5 mm
Depth	114 mm

## Material specifications

Flammability rating according to UL 94 (Housing)	V0 (Housing)
--	--------------

## Environmental and real-life conditions

### Ambient conditions

Degree of protection	IP20
Ambient temperature (operation)	-5 °C ... 60 °C (observe derating)
Ambient temperature (storage/transport)	-40 °C ... 80 °C
Altitude	≤ 2000 m

## Approvals

### UKCA

Certificate	UKCA-compliant
-------------	----------------

# ELR H5-I-PT/500AC-3-IFS - Hybrid motor starter



2905146

<https://www.phoenixcontact.com/us/products/2905146>

## UL approval

Certificate	NLDX.E228652
	NRNT.E172140

## UL data

SCCR	100 kA (480 V AC (fuse: 30 A class CC/30 A class J (high fault)))
	5 kA (480 V AC (fuse: 20 A RK5 (standard fault)))
FLA	3 A (480 V AC)
Group installation	20 A (class RK5, SCCR 5kA (480 V AC), #24 - 14 AWG max. solid and stranded)
	30 A (class CC or J, SCCR 100kA (480 V AC), #24 - 14 AWG max, solid and stranded)
Category code	NLDX / NRNT
Horsepower ratings	0.5 hp (208 V AC)
	0.5 hp (230 V AC)
	0.5 hp (240 V AC)
	1.5 hp (480 V AC)

## Standards and regulations

### Standards/regulations

Standards/regulations	IEC 60947-1
	EN 60947-4-2

## Mounting

Mounting type	DIN rail mounting
Assembly note	alignable, for spacing see derating
Mounting position	vertical (horizontal DIN rail, motor output below)

Drawings

Diagram

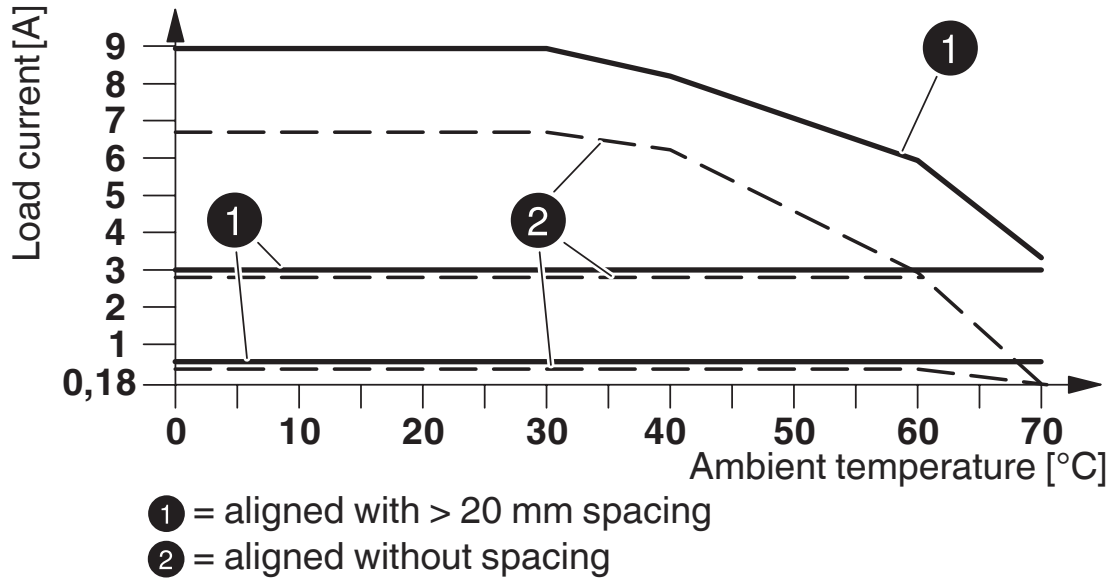

Derating diagram

Block diagram

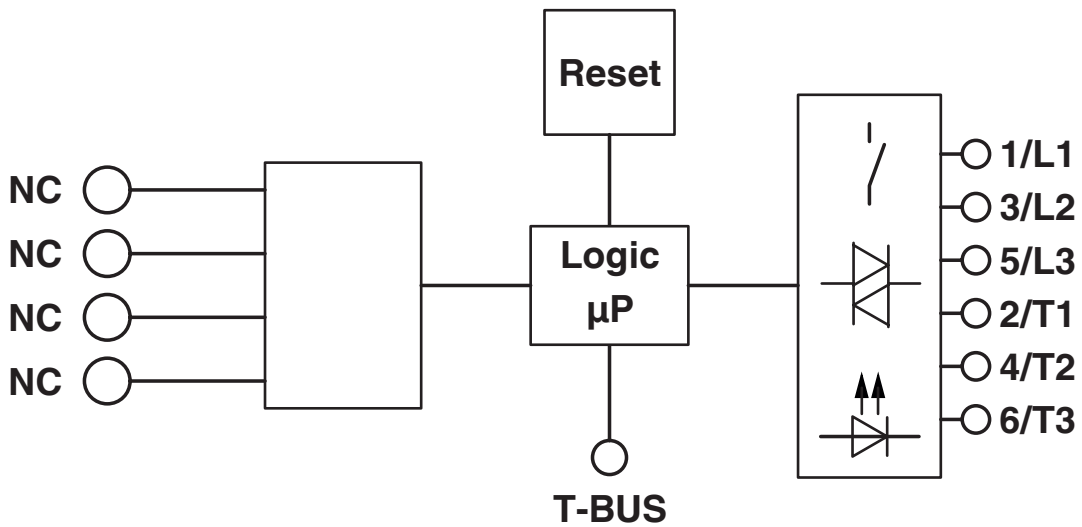

# ELR H5-I-PT/500AC-3-IFS - Hybrid motor starter



2905146

<https://www.phoenixcontact.com/us/products/2905146>

## Classifications

### ECLASS

ECLASS-13.0

27370905

### ETIM

ETIM 9.0

EC001037

### UNSPSC

UNSPSC 21.0

25173900

2905146

<https://www.phoenixcontact.com/us/products/2905146>

## Environmental product compliance

### EU RoHS

Fulfills EU RoHS substance requirements	Yes
Exemption	7(a), 7(c)-I

### China RoHS

Environment friendly use period (EFUP)	EFUP-50
	An article-related China RoHS declaration table can be found in the download area for the respective article under "Manufacturer declaration". For all articles with EFUP-E, no China RoHS declaration table issued and required.

### EU REACH SVHC

REACH candidate substance (CAS No.)	Lead(CAS: 7439-92-1)
SCIP	babcdc3d-cf1b-4996-a459-5e9e6cc6e576

Phoenix Contact 2026 © - all rights reserved

<https://www.phoenixcontact.com>

Phoenix Contact USA  
586 Fulling Mill Road  
Middletown, PA 17057, United States  
(+717) 944-1300  
[info@phoenixcon.com](mailto:info@phoenixcon.com)