

# RAD-ADP-RSMA/M-RSMA/F-90 - Adapter



2904790

<https://www.phoenixcontact.com/us/products/2904790>

Please be informed that the data shown in this PDF document is generated from our online catalog. Please find the complete data in the user documentation. Our general terms of use for downloads are valid.



Antenna adapter, frequency range: 0.3 GHz ... 6 GHz, connection: RSMA (male) -> RSMA (female), 90° angled

## Your advantages

- As an adapter between devices and cables
- Adapter for installing the antenna inside buildings

## Commercial data

Item number	2904790
Packing unit	1 pc
Minimum order quantity	1 pc
Sales key	DN23
Product key	DNC6A3
GTIN	4046356888264
Weight per piece (including packing)	5.3 g
Weight per piece (excluding packing)	5.195 g
Customs tariff number	85366910
Country of origin	US

# RAD-ADP-RSMA/M-RSMA/F-90 - Adapter

2904790

<https://www.phoenixcontact.com/us/products/2904790>

## Technical data

### Notes

#### Note on application

Note on application

Only for industrial use

### Product properties

Product type

Coaxial adapter

### Electrical properties

Frequency range

0.3 GHz ... 6 GHz

### Connection data

Connection method

RSMA (male) -> RSMA (female)

### Dimensions

Dimensional drawing

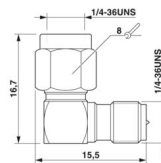

Width

15.5 mm

Height

16.7 mm

### Material specifications

Color

brass color

Housing material

Brass (CuZn)

### Environmental and real-life conditions

#### Ambient conditions

Degree of protection

IP20

Ambient temperature (operation)

-65 °C ... 165 °C

Ambient temperature (storage/transport)

-65 °C ... 165 °C

### Mounting

Assembly note

Indoor installation

# RAD-ADP-RSMA/M-RSMA/F-90 - Adapter

2904790

<https://www.phoenixcontact.com/us/products/2904790>



## Drawings

Dimensional drawing

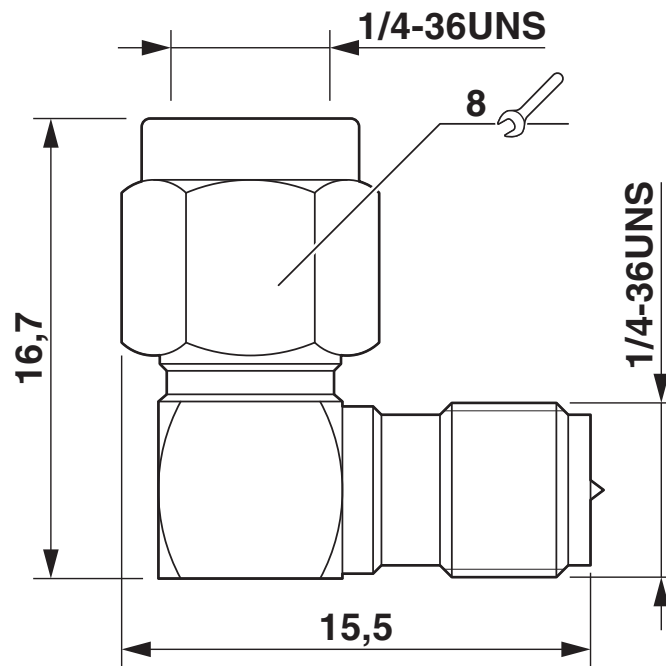

# RAD-ADP-RSMA/M-RSMA/F-90 - Adapter



2904790

<https://www.phoenixcontact.com/us/products/2904790>

## Classifications

### ECLASS

ECLASS-13.0	19070417
ECLASS-15.0	19070417

### ETIM

ETIM 10.0	EC001135
-----------	----------

### UNSPSC

UNSPSC 21.0	39121400
-------------	----------

# RAD-ADP-RSMA/M-RSMA/F-90 - Adapter



2904790

<https://www.phoenixcontact.com/us/products/2904790>

## Environmental product compliance

### China RoHS

Environment friendly use period (EFUP)	EFUP-E
	No hazardous substances above the limits

### EU REACH SVHC

REACH candidate substance (CAS No.)	No substance above 0.1 wt%
-------------------------------------	----------------------------

### EF3.1 Climate Change

CO2e kg	2.159 kg CO2e
---------	---------------

Phoenix Contact 2026 © - all rights reserved  
<https://www.phoenixcontact.com>

Phoenix Contact USA  
586 Fulling Mill Road  
Middletown, PA 17057, United States  
(+717) 944-1300  
[info@phoenixcon.com](mailto:info@phoenixcon.com)