

QUINT4-PS/1AC/48DC/10/CO - Power supply



2904626

<https://www.phoenixcontact.com/us/products/2904626>

Please be informed that the data shown in this PDF document is generated from our online catalog. Please find the complete data in the user documentation. Our general terms of use for downloads are valid.



Primary-switched QUINT POWER power supply with free choice of output characteristic curve, SFB (selective fuse breaking) technology, NFC interface, and protective coating, input: 1-phase, output: 48 V DC / 10 A

Product description

The fourth generation of the high-performance QUINT POWER power supplies ensures superior system availability by means of new functions. Signaling thresholds and characteristic curves can be individually adjusted via the NFC interface. The unique SFB technology and preventive function monitoring of the QUINT POWER power supply increase the availability of your application.

Your advantages

- SFB Technology selectively trips standard miniature circuit breakers
- Preventive function monitoring indicates critical operating states before errors occur
- Power reserves for easy system extension and starting up difficult loads
- High efficiency, long service life, and maximum immunity with integrated gas discharge tube
- Protective coating offers protection against dust, corrosive gases, and humidity

Commercial data

Item number	2904626
Packing unit	1 pc
Minimum order quantity	1 pc
Sales key	CM10
Product key	CMPI14
GTIN	4055626939216
Weight per piece (including packing)	1,658 g
Weight per piece (excluding packing)	1,302 g
Customs tariff number	85044095
Country of origin	TH

Technical data

Input data

Control input (configurable) Rem	Output power ON/OFF (SLEEP MODE)
Default	Output power ON (>40 kΩ/24 V DC/open bridge between Rem and SGnd)

AC operation

Nominal input voltage range	100 V AC ... 240 V AC
Input voltage range	100 V AC ... 240 V AC -15 % ... +10 %
Derating	< 100 V AC (1 %/V)
Electric strength, max.	300 V AC 60 s
Typical national grid voltage	120 V AC 230 V AC
Voltage type of supply voltage	AC
Inrush current	typ. 11 A (at 25 °C)
Inrush current integral (I^2t)	< 0.4 A ² s
Inrush current limitation	11 A (after 1 ms)
AC frequency range	50 Hz ... 60 Hz -10 % ... +10 %
Frequency range (f_N)	50 Hz ... 60 Hz -10 % ... +10 % 16.7 Hz (acc. to EN 50163)
Mains buffering time	typ. 32 ms (120 V AC) typ. 32 ms (230 V AC)
Current consumption	6.8 A (100 V AC) 5.5 A (120 V AC) 2.8 A (230 V AC) 2.7 A (240 V AC)
Nominal power consumption	519 VA
Protective circuit	Transient surge protection; Varistor, gas-filled surge arrester
Switch-on time	< 1 s
Typical response time	300 ms (from SLEEP MODE)
Input fuse	12 A (slow-blow, internal)
Recommended breaker for input protection	10 A ... 16 A (Characteristic B, C, D, K or comparable)
Discharge current to PE	< 3.5 mA 1.3 mA (264 V AC, 60 Hz)

DC operation

Nominal input voltage range	110 V DC ... 250 V DC
Input voltage range	110 V DC ... 250 V DC -18 % ... +40 %
Derating	< 110 V DC (1 %/V)
Voltage type of supply voltage	DC
Current consumption	6 A (110 V DC) 2.5 A (250 V DC)

Output data

Efficiency	typ. 94 % (120 V AC)
	typ. 95 % (230 V AC)
Output characteristic	U/I Advanced
	Smart HICCUP
	FUSE MODE
Nominal output voltage	48 V DC
Setting range of the output voltage (U_{Set})	48 V DC ... 56 V DC (constant capacity)
Nominal output current (I_N)	10 A
Static Boost ($I_{Stat.Boost}$)	12.5 A
Dynamic Boost ($I_{Dyn.Boost}$)	15 A (5 s)
Selective Fuse Breaking (I_{SFB})	60 A (15 ms)
Magnetic circuit breaker tripping	A1...A13 / B2...B6 / C1...C3 / Z1...Z10
Derating	> 60 °C (2.5 %/K)
Feedback voltage resistance	≤ 60 V DC
Protection against overvoltage at the output (OVP)	≤ 60 V DC
Control deviation	< 0.5 % (Static load change 10 % ... 90 %)
	< 2 % (Dynamic load change 10 % ... 90 %, (10 Hz))
	< 0.25 % (change in input voltage ±10 %)
Residual ripple	< 70 mV _{PP} (with nominal values)
Short-circuit-proof	yes
No-load proof	yes
Output power	480 W
	600 W
	720 W
Apparent power	660 VA (120 V, $U_{OUT} = 48$ V, $I_{OUT} = \text{stat. Boost}$)
	644 VA (230 V, $U_{OUT} = 48$ V, $I_{OUT} = \text{stat. Boost}$)
Maximum no-load power dissipation	< 5 W (120 V AC)
	< 5 W (230 V AC)
Power loss nominal load max.	< 36 W (120 V AC)
	< 28 W (230 V AC)
Power dissipation SLEEP MODE	< 5 W (120 V AC)
	< 5 W (230 V AC)
Crest factor	typ. 1.54 (120 V AC)
	typ. 1.56 (230 V AC)
Rise time	< 1 s ($U_{Out} = 10$ % ... 90 %)
Connection in parallel	yes, for redundancy and increased capacity
Connection in series	yes
Fuse protection (secondary side)	electronic
	thermal-magnetic
	thermal

Signal

QUINT4-PS/1AC/48DC/10/CO - Power supply



2904626

<https://www.phoenixcontact.com/us/products/2904626>

Signal ground SGnd	Reference potential for Out1, Out2, and Rem
Signal Out 1 (configurable)	
Digital	24 V DC 20 mA
Default	24 V DC 20 mA 24 V DC for $U_{Out} > 0.9 \times U_{Set}$
Signal Out 2 (configurable)	
Digital	24 V DC 20 mA
Analog	4 mA ... 20 mA $\pm 5\%$ (Load $\leq 400 \Omega$)
Default	24 V DC 20 mA 24 V DC for $P_{Out} < P_N$
Signal relay 13/14 (configurable)	
Default	closed ($U_{out} > 0.9 U_{Set}$)

Connection data

Input

Connection method	Screw connection
Conductor cross-section, rigid min.	0.2 mm ²
Conductor cross-section, rigid max.	6 mm ²
Conductor cross-section flexible min.	0.2 mm ²
Conductor cross-section flexible max.	4 mm ²
Single conductor/flexible terminal point with ferrule with plastic sleeve, min.	0.25 mm ²
Single conductor/flexible terminal point with ferrule with plastic sleeve, max.	4 mm ²
Single conductor/flexible terminal point with ferrule without plastic sleeve, min.	0.25 mm ²
Single conductor/flexible terminal point with ferrule without plastic sleeve, max.	4 mm ²
Conductor cross-section AWG min.	24
Conductor cross-section AWG max.	10
Stripping length	6.5 mm
Tightening torque, min	0.5 Nm
Tightening torque max	0.6 Nm

Output

Connection method	Screw connection
Conductor cross-section, rigid min.	0.2 mm ²
Conductor cross-section, rigid max.	6 mm ²
Conductor cross-section flexible min.	0.2 mm ²
Conductor cross-section flexible max.	4 mm ²
Single conductor/flexible terminal point with ferrule with plastic sleeve, min.	0.25 mm ²
Single conductor/flexible terminal point with ferrule with plastic sleeve, max.	4 mm ²
Single conductor/flexible terminal point with ferrule without plastic sleeve, min.	0.25 mm ²

QUINT4-PS/1AC/48DC/10/CO - Power supply



2904626

<https://www.phoenixcontact.com/us/products/2904626>

Single conductor/flexible terminal point with ferrule without plastic sleeve, max.	4 mm ²
Conductor cross-section AWG min.	24
Conductor cross-section AWG max.	10
Stripping length	6.5 mm
Tightening torque, min	0.5 Nm
Tightening torque max	0.6 Nm

Signal

Connection method	Push-in connection
Conductor cross-section, rigid min.	0.2 mm ²
Conductor cross-section, rigid max.	1 mm ²
Conductor cross-section flexible min.	0.2 mm ²
Conductor cross-section flexible max.	1.5 mm ²
Single conductor/flexible terminal point with ferrule with plastic sleeve, min.	0.2 mm ²
Single conductor/flexible terminal point with ferrule with plastic sleeve, max.	0.75 mm ²
Single conductor/flexible terminal point with ferrule without plastic sleeve, min.	0.2 mm ²
Single conductor/flexible terminal point with ferrule without plastic sleeve, max.	1.5 mm ²
Conductor cross-section AWG min.	24
Conductor cross-section AWG max.	16
Stripping length	8 mm

Signaling

Types of signaling	LED
	Floating signal contact
	Active signal output Out1 (digital, configurable)
	Active signal output Out2 (analog, configurable)
	Remote contact
	Signal ground SGnd

Signal output

Signal option	Output current
	Output voltage
	Output power
	U _{IN} input voltage OK
	Operating hours
	Early warning of high temperatures
	OVP voltage limitation active
P _{Out}	> 100 % (LED lights up yellow, output power > 480 W)
	> 75 % (LED lights up green, output power > 360 W)
	> 50 % (LED lights up green, output power > 240 W)
U _{Out}	> 0.9 x U _{Set} (LED lights up green)

QUINT4-PS/1AC/48DC/10/CO - Power supply



2904626

<https://www.phoenixcontact.com/us/products/2904626>

	< 0.9 x U _{Set} (LED flashes green)
--	--

Electrical properties

Number of phases	1
Insulation voltage input/output	4 kV AC (type test)
	2 kV AC (routine test)
Insulation voltage output / PE	0.5 kV DC (type test)
	0.5 kV DC (routine test)
Insulation voltage input / PE	3.5 kV AC (type test)
	2.4 kV AC (routine test)
Switching frequency	90.00 kHz ... 110.00 kHz (Auxiliary converter stage)
	70.00 kHz ... 330.00 kHz (Main converter stage)
	50.00 kHz ... 70.00 kHz (PFC stage)

Product properties

Product type	Power supply
Product family	QUINT POWER
MTBF (IEC 61709, SN 29500)	> 1100000 h (25 °C)
	> 676000 h (40 °C)
	> 317000 h (60 °C)
Environmental protection directive	RoHS Directive 2011/65/EU
	WEEE
	Reach

Insulation characteristics

Protection class	I
Degree of pollution	2

Life expectancy (electrolytic capacitors)

Current	5 A
Temperature	40 °C
Time	420000 h
Additional text	120 V AC

Life expectancy (electrolytic capacitors)

Current	5 A
Temperature	40 °C
Time	484000 h
Additional text	230 V AC

Life expectancy (electrolytic capacitors)

Current	10 A
Temperature	25 °C
Time	526000 h
Additional text	120 V AC

QUINT4-PS/1AC/48DC/10/CO - Power supply



2904626

<https://www.phoenixcontact.com/us/products/2904626>

Life expectancy (electrolytic capacitors)

Current	10 A
Temperature	25 °C
Time	827000 h
Additional text	230 V AC

Life expectancy (electrolytic capacitors)

Current	10 A
Temperature	40 °C
Time	186000 h
Additional text	120 V AC

Life expectancy (electrolytic capacitors)

Current	10 A
Temperature	40 °C
Time	292000 h
Additional text	230 V AC

Dimensions

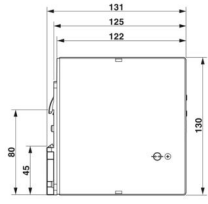
Dimensional drawing	
Width	70 mm
Height	130 mm
Depth	125 mm

Installation dimensions

Installation distance right/left	5 mm / 5 mm
Installation distance top/bottom	50 mm / 50 mm

Alternative assembly

Width	122 mm
Height	130 mm
Depth	73 mm

Mounting

Mounting type	DIN rail mounting
Assembly note	alignable: $P_N \geq 50\%$, 5 mm horizontally, 15 mm next to active components, 50 mm vertically alignable: $P_N < 50\%$, 0 mm horizontally, 40 mm vertically top, 20 mm vertically bottom
Mounting position	horizontal DIN rail NS 35, EN 60715
With protective coating	yes

Material specifications

Flammability rating according to UL 94 (housing / terminal blocks)	V0
Housing material	Metal
Hood version	Stainless steel X6Cr17
Side element version	Aluminum

Environmental and real-life conditions

Ambient conditions

Degree of protection	IP20
Ambient temperature (operation)	-25 °C ... 70 °C (> 60 °C Derating: 2,5 %/K)
Ambient temperature (storage/transport)	-40 °C ... 85 °C
Ambient temperature (start-up type tested)	-40 °C
Maximum altitude	≤ 5000 m (> 2000 m, observe derating)
Climatic class	3K3 (in acc. with EN 60721)
Max. permissible relative humidity (operation)	≤ 100 % (at 25 °C, non-condensing)
Shock	18 ms, 30g, in each space direction (according to IEC 60068-2-27)
Vibration (operation)	5 Hz ... 100 Hz resonance search 2.3g, 90 min., resonance frequency 2.3g, 90 min. (according to DNV GL Class C)
Temp code	T4 (-25 ... +70 °C; > 60 °C, Derating: 2,5 %/K)

Standards and regulations

Rail applications	EN 50121-3-2
	EN 50121-4
	EN 50121-5
	EN 50163
	IEC 62236-3-2
	IEC 62236-4
	IEC 62236-5
HART FSK Physical Layer Test Specification Compliance	Output voltage U_{Out} compliant
Standard – Limitation of mains harmonic currents	EN 61000-3-2
Standard - Electrical safety	IEC 61010-2-201 (SELV)
Standard – Safety extra-low voltage	IEC 61010-1 (SELV)
	IEC 61010-2-201 (PELV)
Standard - Safe isolation	IEC 61558-2-16
	IEC 61010-2-201
Standard - safety for equipment for measurement, control, and laboratory use	IEC 61010-1
Standard - Safety of transformers	EN 61558-2-16
Battery charging	DIN 41773-1
Approval - requirement of the semiconductor industry with regard to mains voltage dips	SEMI F47-0706, EN 61000-4-11

Approvals

CSA	CAN/CSA-C22.2 No. 60950-1-07
	CSA-C22.2 No. 107.1-01
Shipbuilding approval	DNV GL, PRS, BV, LR, ABS
SIQ	BG (type approved)
	CB-Scheme (IEC 61010-1, IEC 61010-2-201, IEC 60950-1)
UL approvals	UL Listed UL 508
	UL/C-UL Recognized UL 60950-1
	UL ANSI/ISA-12.12.01 Class I, Division 2, Groups A, B, C, D T4 (Hazardous Location)

EMC data

Electromagnetic compatibility	Conformance with EMC Directive 2014/30/EU
Low Voltage Directive	Conformance with Low Voltage Directive 2014/35/EC
EMC requirements for noise emission	EN 61000-6-3
	EN 61000-6-4
EMC requirements for noise immunity	EN 61000-6-1
	EN 61000-6-2
EMC requirements for power supply	IEC 61850-3 (G,H)
	EN 61000-6-5 (switching devices)

Conducted noise emission

Standards/regulations	EN 55016
	EN 61000-6-3 (Class B)

Noise emission

Standards/regulations	Additional basic standard EN 61000-6-5 (immunity in switching devices), IEC/EN 61850-3 (power supply)
-----------------------	---

Noise emission

Standards/regulations	EN 55016
	EN 61000-6-3 (Class B)

DNV GL conducted noise emissions

DNV	Class A
Additional text	Area power distribution

DNV GL noise radiation

DNV	Class B
Additional text	Bridge and deck area

Harmonic currents

Standards/regulations	EN 61000-3-2
	EN 61000-3-2 (Class A)
Frequency range	0 kHz ... 2 kHz

Flicker

QUINT4-PS/1AC/48DC/10/CO - Power supply



2904626

<https://www.phoenixcontact.com/us/products/2904626>

Standards/regulations	EN 61000-3-3
	EN 61000-3-3
Frequency range	0 kHz ... 2 kHz

Electrostatic discharge

Standards/regulations	EN 61000-4-2
-----------------------	--------------

Electrostatic discharge

Contact discharge	8 kV (Test Level 4)
Discharge in air	15 kV (Test Level 4)
Comments	Criterion A

Electromagnetic HF field

Standards/regulations	EN 61000-4-3
-----------------------	--------------

Electromagnetic HF field

Frequency range	80 MHz ... 1 GHz
Test field strength	20 V/m (Test Level 3)
Frequency range	1 GHz ... 6 GHz
Test field strength	10 V/m (Test Level 3)
Comments	Criterion A

Fast transients (burst)

Standards/regulations	EN 61000-4-4
-----------------------	--------------

Fast transients (burst)

Input	4 kV (Test Level 4 - asymmetrical)
Output	4 kV (Test Level 4 - asymmetrical)
Signal	4 kV (Test Level 4 - asymmetrical)
Comments	Criterion A

Surge voltage load (surge)

Standards/regulations	EN 61000-4-5
-----------------------	--------------

Surge voltage load (surge)

Input	typ. 3 kV (Test Level 4 - symmetrical)
	typ. 6 kV (Test Level 4 - asymmetrical)
Output	1 kV (Test Level 3 - symmetrical)
	2 kV (Test Level 3 - asymmetrical)
Signal	4 kV (Test Level 4 - asymmetrical)
Comments	Criterion A

Conducted interference

Standards/regulations	EN 61000-4-6
-----------------------	--------------

Conducted interference

Input/output/signal	asymmetrical
Frequency range	0.15 MHz ... 80 MHz

QUINT4-PS/1AC/48DC/10/CO - Power supply



2904626

<https://www.phoenixcontact.com/us/products/2904626>

Comments	Criterion A
Voltage	10 V (Test Level 3)

Power frequency magnetic field

Standards/regulations	EN 61000-4-8
Frequency	16.7 Hz
	50 Hz
	60 Hz
Test field strength	100 A/m
Additional text	60 s
Comments	Criterion A
Frequency	50 Hz
	60 Hz
Frequency range	50 Hz ... 60 Hz
Test field strength	1 kA/m
Additional text	3 s
Frequency	0 Hz
Test field strength	300 A/m
Additional text	DC, 60 s

Voltage dips

Standards/regulations	EN 61000-4-11
Voltage	230 V AC
Frequency	50 Hz
Voltage dip	70 %
Number of periods	0.5 / 1 / 25 / 30 periods
Additional text	Test Level 2
Comments	Criterion A: 0.5 / 1 / 25 / 30 periods
Voltage dip	40 %
Number of periods	5 / 10 / 50 periods
Additional text	Test Level 2
Comments	Criterion A
Voltage dip	0 %
Number of periods	0,5 / 1 / 5 / 50 / 250 periods
Additional text	Test Level 2
Comments	Criterion A: 0.5 / 1 period Criterion B: 5 / 50 / 250 periods

Pulse-shape magnetic field

Standards/regulations	EN 61000-4-9
Test field strength	1000 A/m
Comments	Criterion A

Attenuated sinusoidal oscillations (ring wave)

Standards/regulations	EN 61000-4-12
Input	2 kV (Test Level 4 - symmetrical)

QUINT4-PS/1AC/48DC/10/CO - Power supply



2904626

<https://www.phoenixcontact.com/us/products/2904626>

	4 kV (Test Level 4 - asymmetrical)
Comments	Criterion A

Asymmetrical conducted disturbance variables

Standards/regulations	EN 61000-4-16
Test level 1	15 Hz 150 Hz (Test Level 3)
Voltage	10 V 1 V
Test level 2	150 Hz 1.5 kHz (Test Level 3)
Voltage	1 V
Test level 3	1.5 kHz 15 kHz (Test Level 3)
Voltage	1 V 10 V
Test level 4	15 kHz 150 kHz (Test Level 3)
Voltage	10 V
Test level 5	50 Hz 60 Hz (Test Level 3)
Voltage	10 V (Permanent)
Test level 6	50 Hz 60 Hz (Test Level 3)
Voltage	100 V (1 s)
Comments	Criterion A

Attenuated oscillating wave

Standards/regulations	EN 61000-4-18
Input, output (test level 1)	1 MHz (Test Level 3 - symmetrical)
Voltage	1 kV
Input, output (test level 2)	10 MHz
Voltage	1 kV
Input, output (test level 3)	1 MHz (Test Level 3 - asymmetrical)
Voltage	2.5 kV
Comments	Criterion B

Criteria

Criterion A	Normal operating behavior within the specified limits.
Criterion B	Temporary impairment to operational behavior that is corrected by the device itself.
Criterion C	Temporary adverse effects on the operating behavior, which the device corrects automatically or which can be restored by actuating the operating elements.

QUINT4-PS/1AC/48DC/10/CO - Power supply



2904626

<https://www.phoenixcontact.com/us/products/2904626>

Drawings

Dimensional drawing

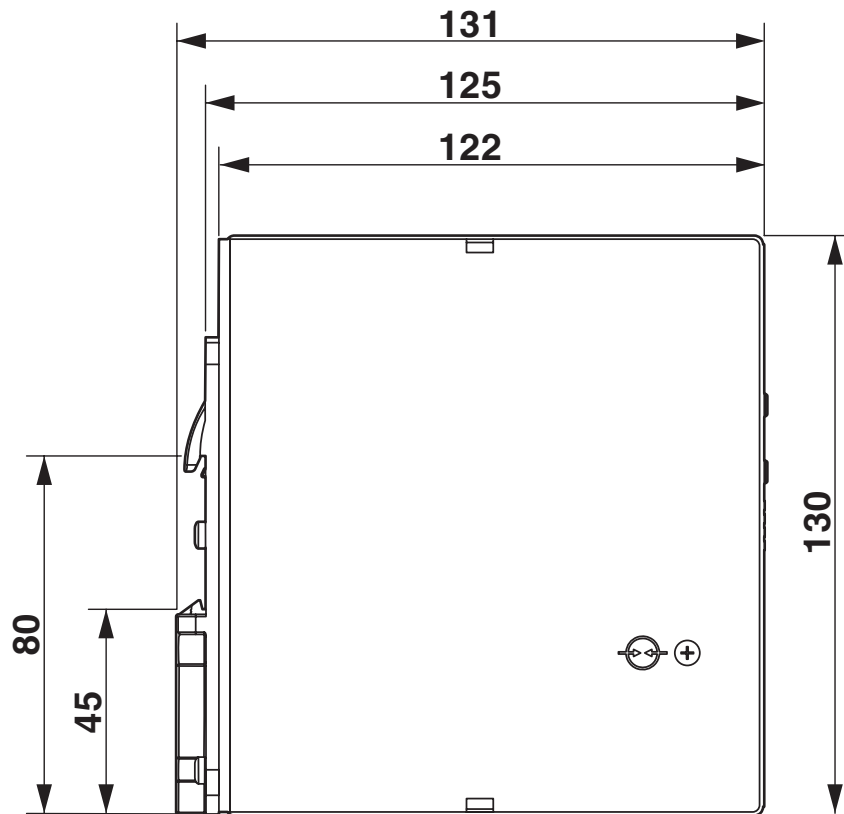

Schematic diagram

Housing

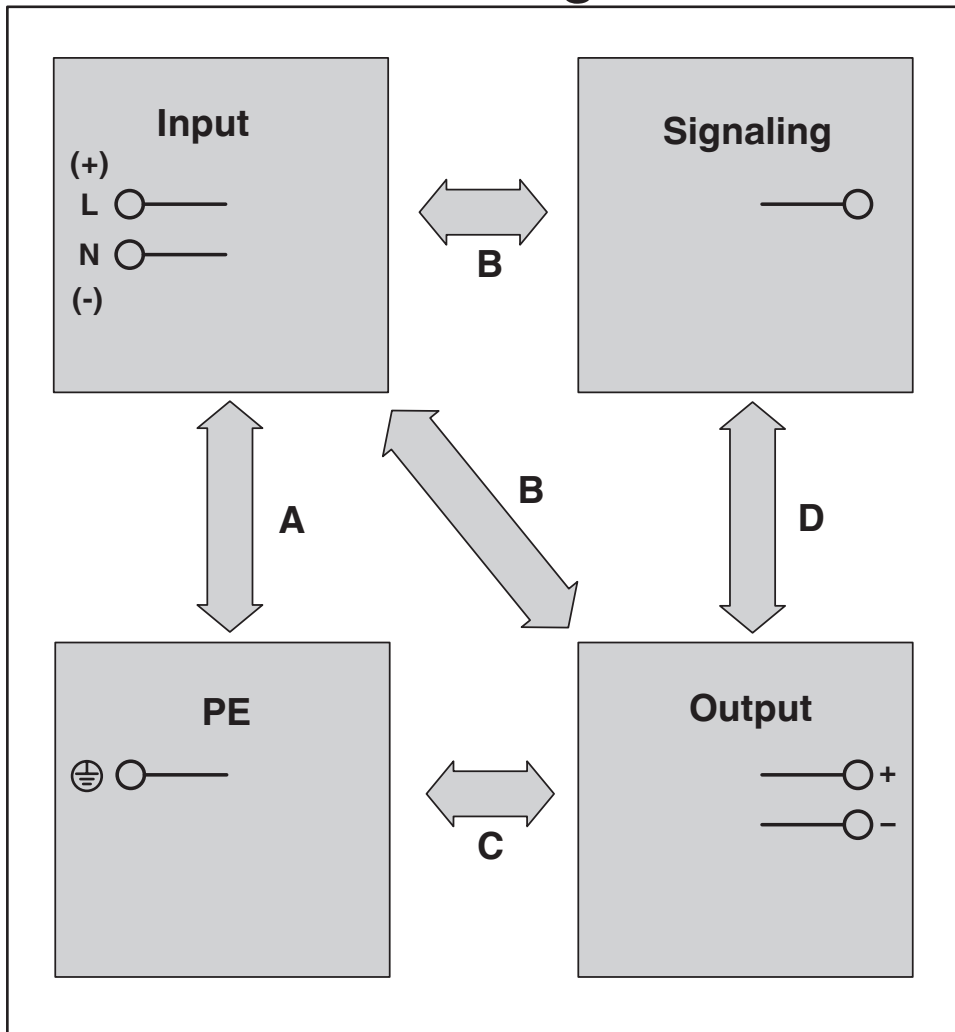

Diagram

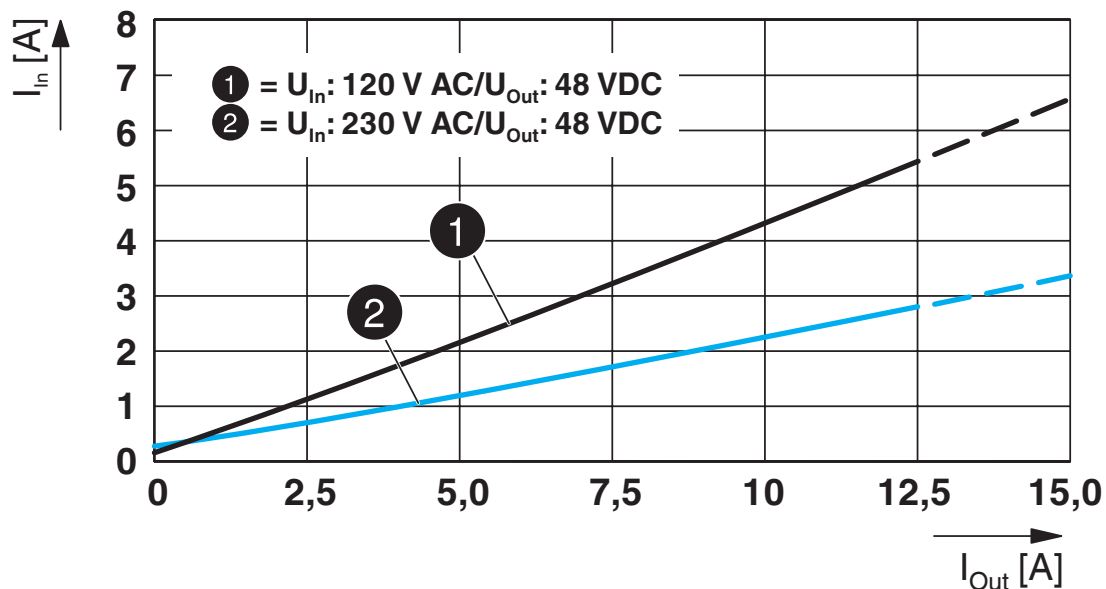

Diagram

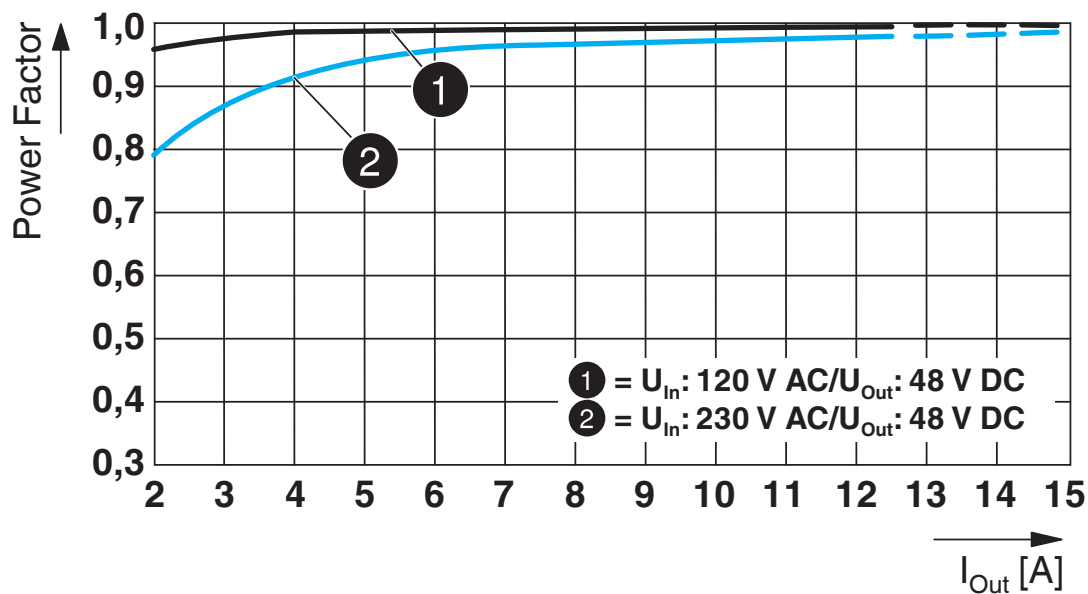

Diagram

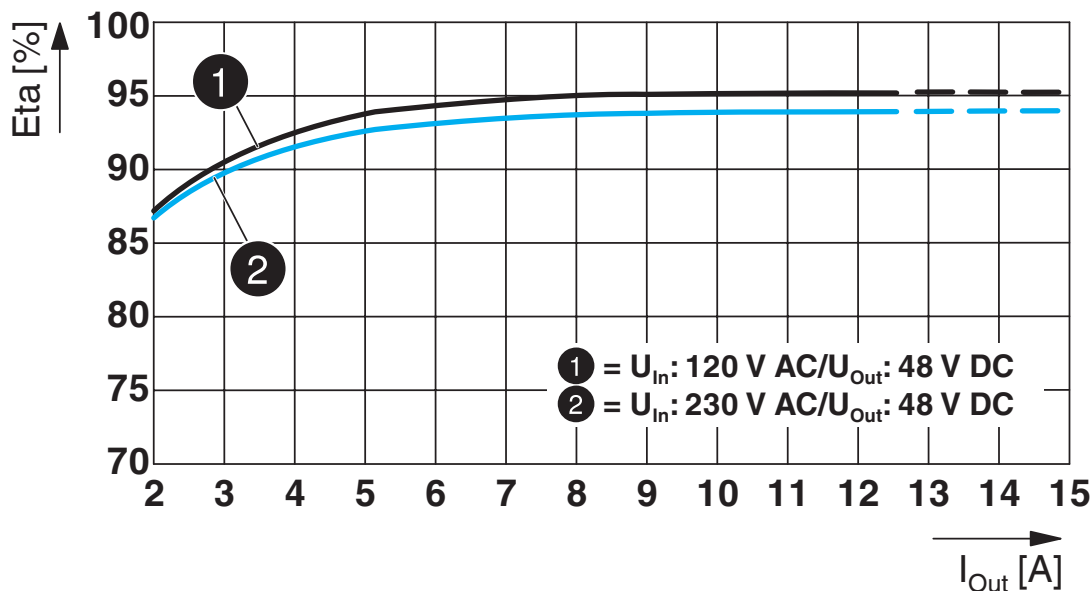

Block diagram

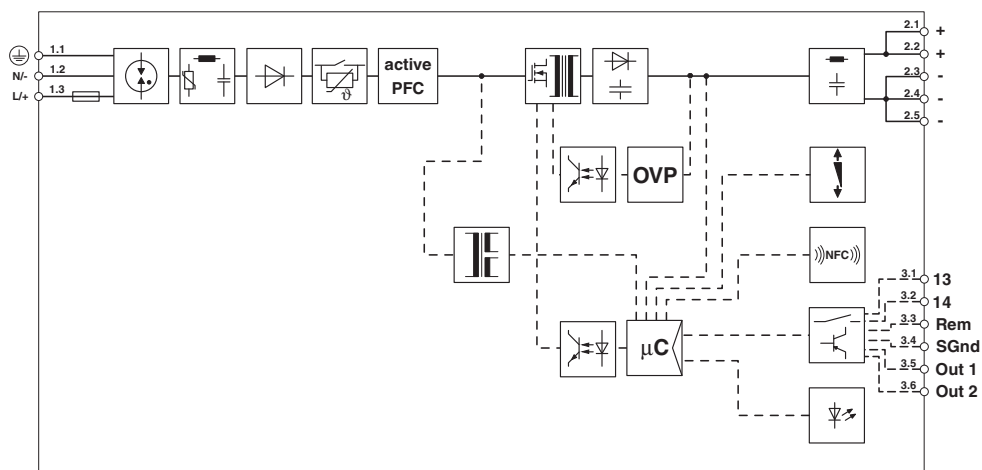

QUINT4-PS/1AC/48DC/10/CO - Power supply



2904626

<https://www.phoenixcontact.com/us/products/2904626>

Approvals

To download certificates, visit the product detail page: <https://www.phoenixcontact.com/us/products/2904626>



cUL Recognized
Approval ID: E211944



UL Recognized
Approval ID: E211944



IECEE CB Scheme
Approval ID: SI-8297



EAC
Approval ID: RU S-DE.BL08.W.00764



LR
Approval ID: LR22472797TA



NK
Approval ID: TA21182M



BV
Approval ID: 44621/B0 BV



EAC
Approval ID: RU S-DE.BL08.W.00764



UL Listed
Approval ID: E123528



cUL Listed
Approval ID: E123528

ABS

Approval ID: 26-0442641-PDA

QUINT4-PS/1AC/48DC/10/CO - Power supply



2904626

<https://www.phoenixcontact.com/us/products/2904626>

DNV

Approval ID: TAA00001YD



cCSAus

Approval ID: 70119409

SEMI F47

Approval ID: SEMI F47



cULus Listed

Approval ID: E199827

QUINT4-PS/1AC/48DC/10/CO - Power supply



2904626

<https://www.phoenixcontact.com/us/products/2904626>

Classifications

ECLASS

ECLASS-13.0	27040701
ECLASS-15.0	27040701

ETIM

ETIM 10.0	EC002540
-----------	----------

UNSPSC

UNSPSC 21.0	39121000
-------------	----------

2904626

<https://www.phoenixcontact.com/us/products/2904626>

Environmental product compliance

EU RoHS

Fulfills EU RoHS substance requirements	Yes
Exemption	6(c), 7(a), 7(c)-I

China RoHS

Environment friendly use period (EFUP)	EFUP-25
	An article-related China RoHS declaration table can be found in the download area for the respective article under "Manufacturer declaration". For all articles with EFUP-E, no China RoHS declaration table issued and required.

EU REACH SVHC

REACH candidate substance (CAS No.)	Lead(CAS: 7439-92-1)
SCIP	f10d40fb-98fa-4da6-b0a7-6e78c717f5fd

EF3.1 Climate Change

CO2e kg	32.23 kg CO2e
---------	---------------

Phoenix Contact 2026 © - all rights reserved
<https://www.phoenixcontact.com>

Phoenix Contact USA
586 Fulling Mill Road
Middletown, PA 17057, United States
(+717) 944-1300
info@phoenixcon.com