

PSR-SPP-24DC/URML4/3X1/1X2/B - Extension module



2903584

<https://www.phoenixcontact.com/us/products/2903584>

Please be informed that the data shown in this PDF document is generated from our online catalog. Please find the complete data in the user documentation. Our general terms of use for downloads are valid.



The figure shows a version with a screw connection

1- or 2-channel contact extension for OSSD signals (e.g., light grid), 3 N/O contacts, 1 N/C contact, up to Cat. 4 PL e in accordance with EN ISO 13849, SIL 3 in accordance with EN IEC 62061, pluggable Push-in terminal block, width: 22.5 mm

Product description

The contact extension device is specifically designed for use in conjunction with electrosensitive protective equipment such as light grids. These systems generally have clocked OSSD signals which enable cross circuits in the cabling to be detected. The relay is resistant to the test pulses generated by the electrosensitive protective equipment receiver. Applications up to PL e or SIL 3 can therefore be implemented without the need for additional traceability to the device on the EDM circuit.

Commercial data

Item number	2903584
Packing unit	1 pc
Minimum order quantity	1 pc
Sales key	DN01
Product key	DNA152
GTIN	4046356751704
Weight per piece (including packing)	172 g
Weight per piece (excluding packing)	147.56 g
Customs tariff number	85371098
Country of origin	DE

PSR-SPP-24DC/URML4/3X1/1X2/B - Extension module



2903584

<https://www.phoenixcontact.com/us/products/2903584>

Technical data

Notes

Note on application

Note on application	Only for industrial use
---------------------	-------------------------

Product properties

Product type	Safety relays
Product family	PSRclassic
Application	Extension module
Control	1 and 2 channel
Mechanical service life	approx. 10^7 cycles
Relay type	Electromechanical relay with force-guided contacts in accordance with IEC/EN 61810-3

Insulation characteristics

Overvoltage category	III
Degree of pollution	2

Times

Typical response time	125 ms (For U_S autostart)
Typical release time	10 ms (on demand via the sensor circuit)
Recovery time	1 s (following demand of the safety function)

Electrical properties

Maximum power dissipation for nominal condition	16.44 W ($U_S = 26.4$ V, $I_L^2 = 72$ A ² , $P_{Total\ max} = 2.04$ W + 14.4 W)
Nominal operating mode	100% operating factor
Rated insulation voltage	250 V
Rated surge voltage/insulation	4 kV / Basic isolation, (safe isolation, reinforced insulation and 6 kV between input circuit and enabling current paths.)

Input data

Digital: Logic (S12, S22)

Description of the input	safety-related
Number of inputs	2
Input voltage range "0" signal	0 V DC ... 5 V DC
Input voltage range "1" signal	20.4 V ... 26.4 V
Input current range "0" signal	0 mA ... 2 mA
Inrush current	max. 110 mA (typ. with U_S , $\Delta t = 3$ ms)
Filter time	max. 2 ms (Test pulse width low test pulses, at 100 ms test pulse rate) No brightness test pulses / high test pulses permitted.
Concurrence	∞
Max. permissible overall conductor resistance	50 Ω

PSR-SPP-24DC/URML4/3X1/1X2/B - Extension module



2903584

<https://www.phoenixcontact.com/us/products/2903584>

Protective circuit	Suppressor diode
Current consumption	38 mA (typical, at 24 V)

Output data

Relay: Enabling current paths (13/14, 23/24, 33/34)

Output description	2 N/O contacts each in series, safety-related, floating
Number of outputs	3
Contact switching type	3 enabling current paths
Contact material	AgSnO ₂
Switching voltage	min. 10 V max. 250 V AC/DC
Switching power	min. 100 mW
Inrush current	min. 10 mA max. 6 A
Switching capacity	5 A (AC15) 6 A (DC13)
Limiting continuous current	6 A (Observe derating and load limit curve)
Sq. Total current	72 A ² (observe derating)
Switching frequency	max. 0.5 Hz
Mechanical service life	10x 10 ⁶ cycles
Output fuse	10 A gL/gG 4 A gL/gG (for low-demand applications)

Relay: Signaling current path (41/42)

Output description	2 N/C contacts parallel, non-safety-related, floating
Number of outputs	1
Contact switching type	1 signaling current path
Contact material	AgSnO ₂
Switching voltage	min. 10 V AC/DC max. 250 V AC/DC
Switching power	min. 100 mW
Inrush current	min. 10 mA max. 6 A
Switching capacity	1.5 A (AC15) 2 A (DC13)
Limiting continuous current	6 A
Sq. Total current	36 A ²
Switching frequency	max. 0.5 Hz
Mechanical service life	10x 10 ⁶ cycles
Output fuse	6 A gL/gG

Connection data

Connection technology

pluggable	yes
-----------	-----

PSR-SPP-24DC/URML4/3X1/1X2/B - Extension module



2903584

<https://www.phoenixcontact.com/us/products/2903584>

Conductor connection

Connection method	Push-in connection
Conductor cross-section rigid	0.2 mm ² ... 1.5 mm ²
Conductor cross-section flexible	0.2 mm ² ... 1.5 mm ²
Conductor cross-section, flexible, with ferrule, with plastic sleeve	0.25 mm ² ... 1.5 mm ² (only together with CRIMPFOX 6)
Conductor cross-section, flexible, with ferrule, without plastic sleeve	0.25 mm ² ... 1.5 mm ² (only together with CRIMPFOX 6)
Conductor cross-section AWG	24 ... 16
Stripping length	8 mm

Signaling

Status display	2 x LED (green)
----------------	-----------------

Dimensions

Width	22.5 mm
Height	117.5 mm
Depth	114.5 mm

Material specifications

Color (Housing)	yellow (RAL 1018)
Housing material	PA

Characteristics

Safety data

Stop category (EN 60204-1)	0
----------------------------	---

Safety data: EN ISO 13849

Performance level (PL)	e (5 A DC13; 5 A AC15; 8760 switching cycles/year)
------------------------	--

Safety data: IEC 61508 - High demand

Safety Integrity Level (SIL)	3
------------------------------	---

Safety data: IEC 61508 - Low demand

Safety Integrity Level (SIL)	3
------------------------------	---

Safety data: EN IEC 62061

Safety Integrity Level (SIL)	3
------------------------------	---

Environmental and real-life conditions

Ambient conditions

Degree of protection	IP20
Min. degree of protection of inst. location	IP54
Ambient temperature (operation)	-20 °C ... 55 °C
Ambient temperature (storage/transport)	-40 °C ... 70 °C
Maximum altitude	≤ 2000 m (Above sea level)

PSR-SPP-24DC/URML4/3X1/1X2/B - Extension module



2903584

<https://www.phoenixcontact.com/us/products/2903584>

Max. permissible humidity (storage/transport)	75 % (on average, 85% infrequently, non-condensing)
Max. permissible relative humidity (operation)	75 % (on average, 85% infrequently, non-condensing)
Shock	15g
Vibration (operation)	10 Hz ... 150 Hz, amplitude 0.15 mm, 2g

Approvals

CE

Identification	CE-compliant
----------------	--------------

Mounting

Mounting type	DIN rail mounting
Mounting position	vertical or horizontal

PSR-SPP-24DC/URML4/3X1/1X2/B - Extension module



2903584

<https://www.phoenixcontact.com/us/products/2903584>

Drawings

Circuit diagram

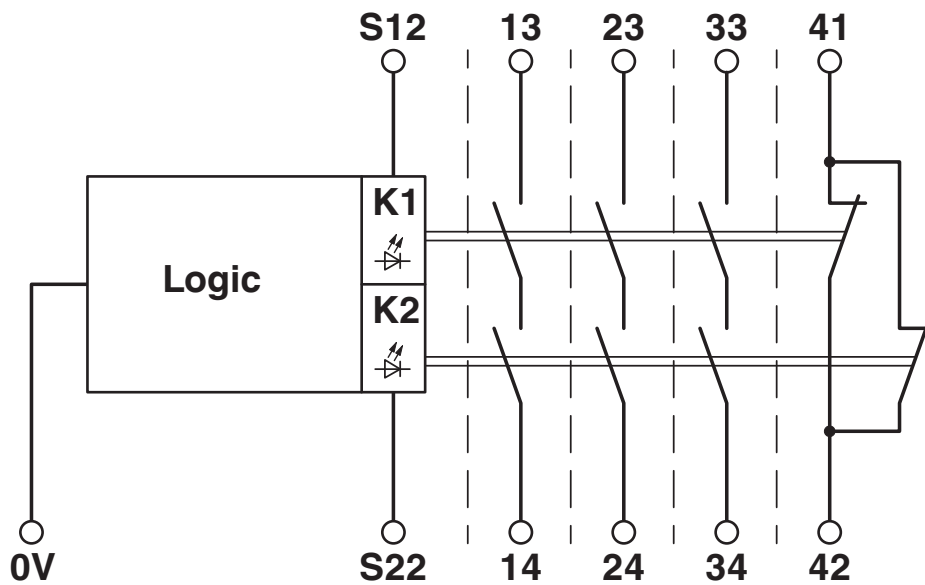

Block diagram

Circuit diagram



Two-channel light grid monitoring

PSR-SPP-24DC/URML4/3X1/1X2/B - Extension module



2903584

<https://www.phoenixcontact.com/us/products/2903584>

Approvals

To download certificates, visit the product detail page: <https://www.phoenixcontact.com/us/products/2903584>



cULus Listed

Approval ID: E140324



Functional Safety

Approval ID: 01/205/5265.04/23

PSR-SPP-24DC/URML4/3X1/1X2/B - Extension module



2903584

<https://www.phoenixcontact.com/us/products/2903584>

Classifications

ECLASS

ECLASS-13.0	27371819
ECLASS-15.0	27371819
ECLASS-15.0 ASSET	27250101

ETIM

ETIM 10.0	EC001449
-----------	----------

UNSPSC

UNSPSC 21.0	39122200
-------------	----------

PSR-SPP-24DC/URML4/3X1/1X2/B - Extension module



2903584

<https://www.phoenixcontact.com/us/products/2903584>

Environmental product compliance

EU RoHS

Fulfills EU RoHS substance requirements	Yes
Exemption	7(a), 7(c)-I

China RoHS

Environment friendly use period (EFUP)	EFUP-50
	An article-related China RoHS declaration table can be found in the download area for the respective article under "Manufacturer declaration". For all articles with EFUP-E, no China RoHS declaration table issued and required.

EU REACH SVHC

REACH candidate substance (CAS No.)	Lead(CAS: 7439-92-1)
SCIP	64277b0b-6944-4767-95cd-4099a6ed308d

EF3.1 Climate Change

CO2e kg	4.468 kg CO2e
---------	---------------

Phoenix Contact 2026 © - all rights reserved
<https://www.phoenixcontact.com>

Phoenix Contact USA
586 Fulling Mill Road
Middletown, PA 17057, United States
(+717) 944-1300
info@phoenixcon.com