

FL-PP-RJ45-SCC/SC041 - Patch panel



2903532

<https://www.phoenixcontact.com/us/products/2903532>

Please be informed that the data shown in this PDF document is generated from our online catalog. Please find the complete data in the user documentation. Our general terms of use for downloads are valid.



Cable sharing module, two RJ45 jacks with Ethernet assignment (cable outlet on the front) to 8 spring-cage connection terminal blocks, CAT5e, 10/100 Mbps, DIN rail mounting, IP20, option of shield contacting on DIN rail via jumpers

Product description

Ethernet patch panels enable quick and easy connection between the field cabling and control cabinet cabling. The passive termination panels are a convenient alternative to the on-site assembly of RJ45 connectors.

Your advantages

- Safe shield connection to ground potential
- CAT5e
- 10/100 Mbps
- Mounting on a DIN rail
- Cable sharing adapter
- Y adapter
- Easy use of one cable for various services
- Optional shield connection via jumpers



Commercial data

Item number	2903532
Packing unit	1 pc
Minimum order quantity	1 pc
Sales key	DN07
Product key	DNC331

FL-PP-RJ45-SCC/SC041 - Patch panel



2903532

<https://www.phoenixcontact.com/us/products/2903532>

GTIN	4046356746748
Weight per piece (including packing)	93.2 g
Weight per piece (excluding packing)	64.3 g
Customs tariff number	85366990
Country of origin	US

Technical data

Notes

Note on application

Note on application	Only for industrial use
---------------------	-------------------------

Product properties

Product type	Patch panel
--------------	-------------

Insulation characteristics: Air clearances and creepage distances

Insulation	Basic insulation
Overvoltage category	II
Pollution degree	2

Electrical properties

Air clearances and creepage distances

Rated insulation voltage	50 V
Rated surge voltage	0.5 kV

Interfaces

Data: Ethernet interface, 10/100/1000Base-T(X) in accordance with IEEE 802.3

Serial transmission speed	10/100 Mbps
Connection method	Spring-cage connection
No. of channels	1
Pin assignment	1, 2, 3, 6 4, 5, 7, 8
Transmission length	100 m (including patch cables)
Single conductor/terminal point, rigid	0.2 mm ² ... 1.5 mm ²
Single-wire/terminal point, flexible	0.2 mm ² ... 1 mm ²
Single-wire/terminal point, rigid AWG max.	16
Single-wire/terminal point, rigid AWG min.	24

Data: Ethernet interface, 10/100/1000Base-T(X) in accordance with IEEE 802.3

Connection method	RJ45 CAT5e
No. of channels	1
Pin assignment	1, 2, 3, 6 1, 2, 3, 6

Dimensions

Width	52 mm
Height	90 mm
Depth	51 mm

2903532

<https://www.phoenixcontact.com/us/products/2903532>

Material specifications

Color (Housing)	green (RAL 6021)
-----------------	------------------

Cable/line

External cable diameter	6 mm ... 10 mm
Cable impedance	100 Ω

Mechanical properties

Mechanical data

Insertion/withdrawal cycles	≤ 750
-----------------------------	-------

Environmental and real-life conditions

Ambient conditions

Degree of protection	IP20
Ambient temperature (operation)	-10 °C ... 50 °C

Approvals

Corrosive gas test

Identification	ISA-S71.04-1985 G3 Harsh Group A
----------------	----------------------------------

Standards and regulations

Air clearances and creepage distances

Standards/regulations	DIN EN 50178
-----------------------	--------------

Mounting

Mounting type	DIN rail mounting
Mounting position	any

FL-PP-RJ45-SCC/SC041 - Patch panel



2903532

<https://www.phoenixcontact.com/us/products/2903532>

Drawings

Connection diagram

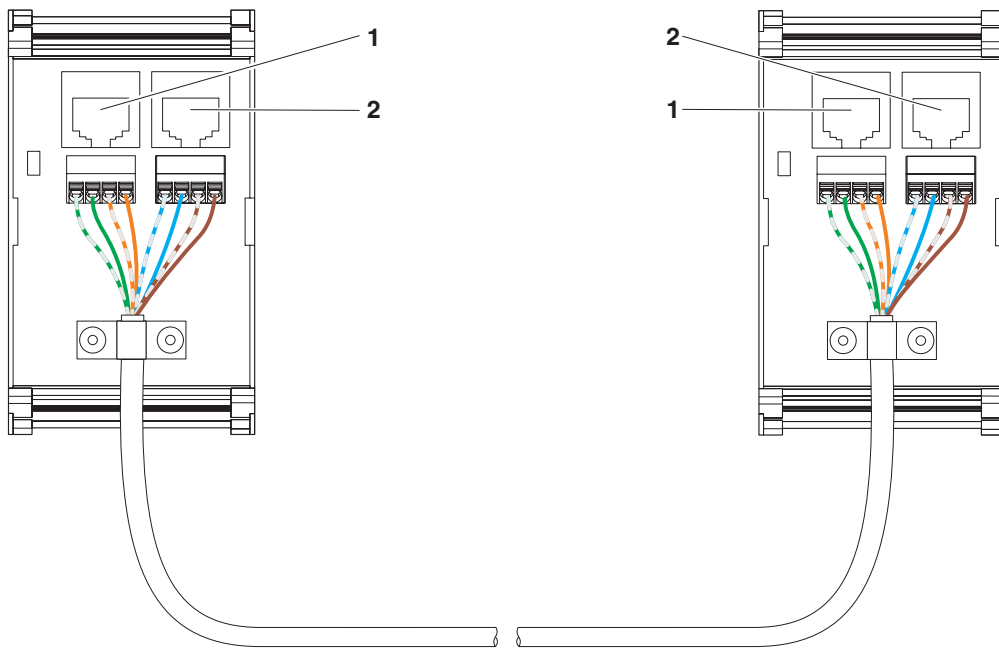

Device connections

Circuit diagram

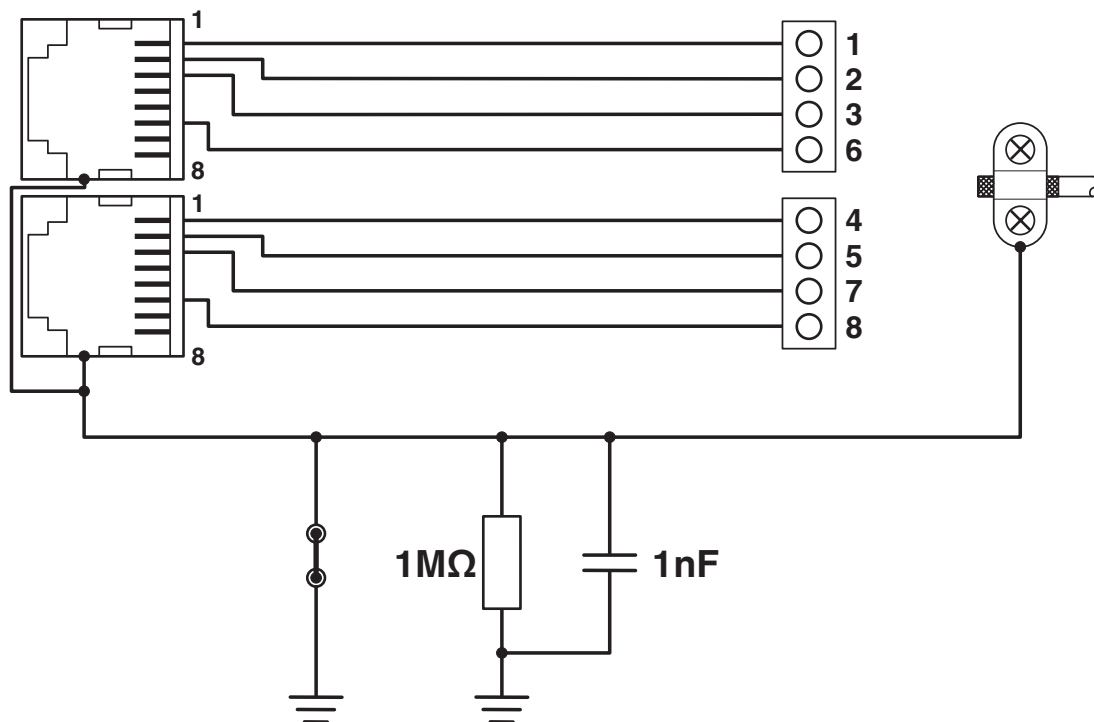

Circuit diagram

2903532

<https://www.phoenixcontact.com/us/products/2903532>

Circuit diagram

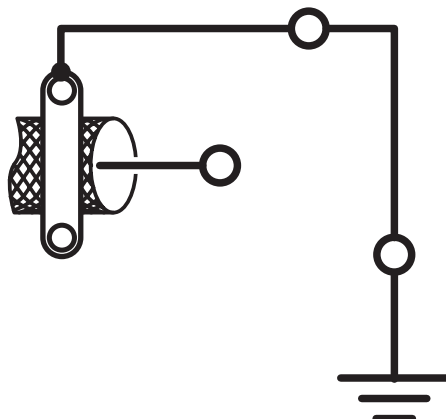

Shield connection direct to PE

Circuit diagram

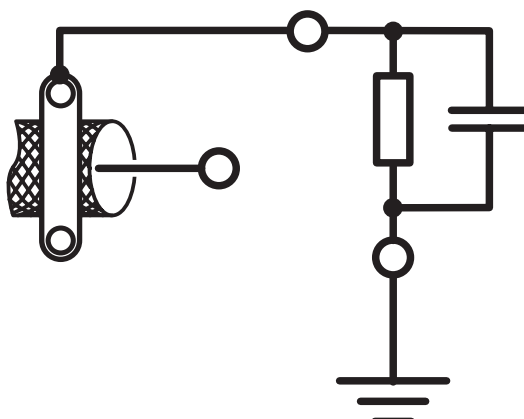

Shield connection to PE via RC element

FL-PP-RJ45-SCC/SC041 - Patch panel

2903532

<https://www.phoenixcontact.com/us/products/2903532>



Circuit diagram

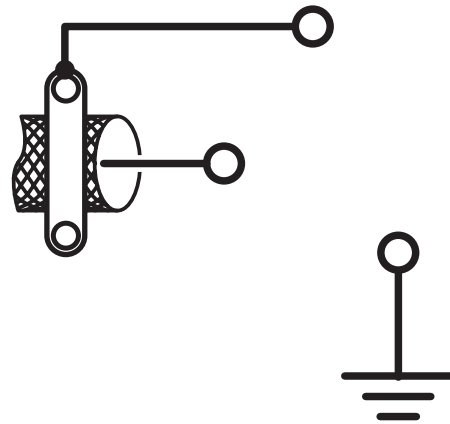

FL-PP-RJ45-SCC/SC041 - Patch panel



2903532

<https://www.phoenixcontact.com/us/products/2903532>

Classifications

ECLASS

ECLASS-13.0	19170112
ECLASS-15.0	19170112

ETIM

ETIM 10.0	EC001128
-----------	----------

UNSPSC

UNSPSC 21.0	43223300
-------------	----------

2903532

<https://www.phoenixcontact.com/us/products/2903532>

Environmental product compliance

EU RoHS

Fulfills EU RoHS substance requirements	Yes, No exemptions
---	--------------------

China RoHS

Environment friendly use period (EFUP)	EFUP-50
	An article-related China RoHS declaration table can be found in the download area for the respective article under "Manufacturer declaration". For all articles with EFUP-E, no China RoHS declaration table issued and required.

EU REACH SVHC

REACH candidate substance (CAS No.)	No substance above 0.1 wt%
-------------------------------------	----------------------------

Phoenix Contact 2026 © - all rights reserved

<https://www.phoenixcontact.com>

Phoenix Contact USA
586 Fulling Mill Road
Middletown, PA 17057, United States
(+717) 944-1300
info@phoenixcon.com