

# TRIO-PS-2G/1AC/48DC/5 - Power supply



2903159

<https://www.phoenixcontact.com/us/products/2903159>

Please be informed that the data shown in this PDF document is generated from our online catalog. Please find the complete data in the user documentation. Our general terms of use for downloads are valid.



Primary-switched TRIO power supply for DIN rail mounting, input: 1-phase, output: 48 V DC / 5 A, dynamic boost, tool-free fast connection technology for solid and stranded conductors with ferrule

## Product description

TRIO POWER power supplies with standard functionality

The TRIO POWER power supply range with push-in connection has been perfected for use in machine building. All functions and the space-saving design of the single and three-phase modules are optimally tailored to the stringent requirements. Under challenging ambient conditions, the power supply units, which feature an extremely robust electrical and mechanical design, ensure the reliable supply of all loads.

## Your advantages

- Save time and costs, thanks to the Push-in connection and narrow design
- Increase system availability, thanks to dynamic boost with 150 % of the nominal current for 5 seconds
- Maximum flexibility due to the wide temperature range from -25°C to +70°C and device startup at -40°C
- Electrically robust, thanks to high electric strength
- Mechanically robust, thanks to high vibration and shock resistance

## Commercial data

Item number	2903159
Packing unit	1 pc
Minimum order quantity	1 pc
Sales key	CM12
Product key	CMPO14
GTIN	4055626255422
Weight per piece (including packing)	1,128 g
Weight per piece (excluding packing)	1,128 g
Customs tariff number	85044095
Country of origin	CN

## Technical data

### Input data

#### AC operation

Network type	Star network
Nominal input voltage range	100 V AC ... 240 V AC
Input voltage range	100 V AC ... 240 V AC -15 % ... +10 %
Electric strength, max.	≤ 300 V AC 15 s
Typical national grid voltage	120 V AC
	230 V AC
Voltage type of supply voltage	AC
Inrush current integral ( $I^2t$ )	< 0.3 A <sup>2</sup> s
Inrush current limitation	15 A (after 1 ms)
AC frequency range	50 Hz ... 60 Hz ±10 %
Frequency range ( $f_N$ )	50 Hz ... 60 Hz ±5 Hz
Mains buffering time	typ. 15 ms (120 V AC)
	typ. 15 ms (230 V AC)
Current consumption	2.9 A (100 V AC)
	2.3 A (120 V AC)
	1.2 A (230 V AC)
	1.2 A (240 V AC)
Nominal power consumption	285.7 VA
Protective circuit	Transient surge protection; Varistor
Power factor (cos phi)	0.91
Input fuse	6.3 A (internal (device protection))
Recommended breaker for input protection	6 A ... 16 A (Characteristics B, C, D, K)
Discharge current to PE	< 3.5 mA
	< 1.7 mA (264 V AC, 60 Hz)
Power factor	> 0.9 (120 V AC)
	> 0.9 (230 V AC)

#### DC operation

Nominal input voltage range	110 V DC ... 250 V DC
Input voltage range	110 V DC ... 250 V DC ±10 %
Extended input voltage range in operation	> 88 V DC (Derating <99 V DC: 2 %/V)
Derating	< 99 V DC (2 %/V)
Switch-on voltage	90 V DC
Shut-down voltage	70 V DC
Voltage type of supply voltage	DC
Mains buffering time	> 20 ms (230 V AC)
Current consumption	2.5 A (110 V DC)
	1.1 A (250 V DC)

## Output data

Efficiency	typ. 90.5 % (120 V AC)
	typ. 91 % (230 V AC)
Output characteristic	U/I with dynamic load reserve
Nominal output voltage	48 V DC $\pm$ 1 %
Setting range of the output voltage ( $U_{Set}$ )	36 V DC ... 55 V DC (> 48 V DC, constant capacity restricted)
Nominal output current ( $I_N$ )	5 A
Dynamic Boost ( $I_{Dyn.Boost}$ )	7.5 A (5 s)
Derating	> 60 °C ... 70 °C (2.5 %/K)
Power factor	> 0.9 (120 V AC)
	> 0.9 (230 V AC)
Feedback voltage resistance	$\leq$ 60 V DC
Protection against overvoltage at the output (OVP)	$\leq$ 60 V DC
Control deviation	< 1 % (change in load, static 10 % ... 90 %)
	< 3 % (Dynamic load change 10 % ... 90 %, 10 Hz)
	< 0.1 % (change in input voltage $\pm$ 10 %)
Residual ripple	< 20 mV <sub>PP</sub> (with nominal values)
Short-circuit-proof	yes
No-load proof	yes
Output power	240 W
	360 W (5 s)
Peak switching voltages nominal load	< 15 mV <sub>PP</sub>
Maximum no-load power dissipation	typ. 4 W (120 V AC)
	typ. 4.1 W (230 V AC)
Power loss nominal load max.	typ. 24.5 W (120 V AC)
	typ. 20.1 W (230 V AC)
Short-circuit current	< 7 A DC (permanent)
Rise time	20 ms ( $U_{OUT}$ (10 % ... 90 %))
Connection in parallel	yes, for redundancy and increased capacity
Connection in series	yes

### Signal: DC OK

Continuous load current	100 mA
-------------------------	--------

### Signal relay 13/14

Default	closed
Digital	30 V AC 30 V DC 100 mA

## Connection data

### Input

Connection method	Push-in connection
Conductor cross-section, rigid min.	0.2 mm <sup>2</sup>
Conductor cross-section, rigid max.	4 mm <sup>2</sup>
Conductor cross-section flexible min.	0.2 mm <sup>2</sup>

# TRIO-PS-2G/1AC/48DC/5 - Power supply



2903159

<https://www.phoenixcontact.com/us/products/2903159>

Conductor cross-section flexible max.	2.5 mm <sup>2</sup>
Single conductor/terminal point, stranded, with ferrule, min.	0.2 mm <sup>2</sup>
Single conductor/terminal point, stranded, with ferrule, max.	2.5 mm <sup>2</sup>
Conductor cross-section AWG min.	24
Conductor cross-section AWG max.	12
Stripping length	10 mm

## Output

Connection method	Push-in connection
Conductor cross-section, rigid min.	0.2 mm <sup>2</sup>
Conductor cross-section, rigid max.	4 mm <sup>2</sup>
Conductor cross-section flexible min.	0.2 mm <sup>2</sup>
Conductor cross-section flexible max.	2.5 mm <sup>2</sup>
Single conductor/terminal point, stranded, with ferrule, min.	0.2 mm <sup>2</sup>
Single conductor/terminal point, stranded, with ferrule, max.	2.5 mm <sup>2</sup>
Conductor cross-section AWG min.	24
Conductor cross-section AWG max.	12
Stripping length	8 mm

## Signal

Connection method	Push-in connection
Conductor cross-section, rigid min.	0.2 mm <sup>2</sup>
Conductor cross-section, rigid max.	1.5 mm <sup>2</sup>
Conductor cross-section flexible min.	0.2 mm <sup>2</sup>
Conductor cross-section flexible max.	1.5 mm <sup>2</sup>
Single conductor/terminal point, stranded, with ferrule, min.	0.2 mm <sup>2</sup>
Single conductor/terminal point, stranded, with ferrule, max.	1.5 mm <sup>2</sup>
Conductor cross-section AWG min.	24
Conductor cross-section AWG max.	16
Stripping length	8 mm

## Signaling

Types of signaling	LED
	Floating signal contact

## Signal output: LED status indicator

Signalization designation	DC OK
Status display	LED
Color	green
DC OK	$U_{OUT} > 0.7 \times U_N$ ( $U_N = 48$ V DC)
13/14	$U_{OUT} > 0.7 \times U_N$ ( $U_N = 48$ V DC)

## Electrical properties

Number of phases	1
Insulation voltage input/output	3 kV AC (type test)

# TRIO-PS-2G/1AC/48DC/5 - Power supply



2903159

<https://www.phoenixcontact.com/us/products/2903159>

	1.5 kV AC (routine test)
--	--------------------------

## Product properties

Product type	Power supply
Product family	TRIO POWER
MTBF (IEC 61709, SN 29500)	> 2000000 h (25 °C)
	> 1200000 h (40 °C)
	> 620000 h (60 °C)

## Insulation characteristics

Protection class	I (in closed control cabinet)
Overvoltage category (EN 62368-1)	II ( $\leq 2000$ m)
Degree of pollution	2

## Dimensions

Width	42 mm
Height	130 mm
Depth	160 mm

## Installation dimensions

Installation distance right/left	0 mm / 0 mm
Installation distance top/bottom	50 mm / 50 mm

## Mounting

Mounting type	DIN rail mounting
Assembly note	alignable: horizontally 0 mm ( $\leq 40$ °C) 10 mm ( $\leq 70$ °C), vertically 50 mm
Mounting position	horizontal DIN rail NS 35, EN 60715
With protective coating	no

## Material specifications

Flammability rating according to UL 94 (housing / terminal blocks)	V0
Housing material	Metal
Type of housing	Aluminum (AlMg3)
Hood version	Polycarbonate

## Environmental and real-life conditions

### Ambient conditions

Degree of protection	IP20
Ambient temperature (operation)	-25 °C ... 70 °C (> 60 °C Derating: 2,5 %/K)
Ambient temperature (storage/transport)	-40 °C ... 85 °C
Ambient temperature (start-up type tested)	-40 °C
Maximum altitude	$\leq 5000$ m (> 2000 m, Derating: 10 %/1000 m)
Climatic class	3K3 (in acc. with EN 60721)
Max. permissible relative humidity (operation)	$\leq 95$ % (at 25 °C, non-condensing)

# TRIO-PS-2G/1AC/48DC/5 - Power supply



2903159

<https://www.phoenixcontact.com/us/products/2903159>

Shock	18 ms, 30g, in each space direction (according to IEC 60068-2-27)
Vibration (operation)	< 15 Hz, amplitude $\pm 2.5$ mm (according to IEC 60068-2-6)
	15 Hz ... 150 Hz, 4g, 90 min.
	DNV GL CG-0339 / Class B 2 Hz - 100 Hz resonance search, 90 min. in resonance, 2 Hz - 25 Hz, $\pm 1.6$ mm amplitude, 25 Hz - 100 Hz, 4g acceleration

## Standards and regulations

Rail applications	EN 50121-4
Standard – Limitation of mains harmonic currents	EN 61000-3-2
Standard - Electrical safety	IEC 62368-1 (SELV)
Standard – Safety extra-low voltage	IEC 62368-1 (SELV) und EN 60204-1 (PELV)
Standard - Safe isolation	DIN VDE 0100-410
Standard - Safety of power supply units up to 1100 V (insulation distances)	DIN EN 61558-2-16

## Approvals

UL approvals	UL Listed UL 508
	UL/C-UL Recognized UL 60950-1
	UL ANSI/ISA-12.12.01 Class I, Division 2, Groups A, B, C, D (Hazardous Location)

## Conformity/Approvals

SIL in accordance with IEC 61508	0
----------------------------------	---

## EMC data

Electromagnetic compatibility	Conformance with EMC Directive 2014/30/EU
Low Voltage Directive	Conformance with Low Voltage Directive 2014/35/EC
EMC requirements for noise emission	EN 61000-6-3
	EN 61000-6-4
EMC requirements for noise immunity	EN 61000-6-1
	EN 61000-6-2

## Conducted noise emission

Standards/regulations	EN 55016
	EN 61000-6-3 (Class B)

## Noise emission

Standards/regulations	EN 55011 (EN 55022)
-----------------------	---------------------

## Noise emission

Standards/regulations	EN 55016
	EN 61000-6-3 (Class B)

## Harmonic currents

Frequency range	Class A
-----------------	---------

# TRIO-PS-2G/1AC/48DC/5 - Power supply



2903159

<https://www.phoenixcontact.com/us/products/2903159>

## Flicker

Frequency range	0 kHz ... 2 kHz
-----------------	-----------------

## Electrostatic discharge

Standards/regulations	EN 61000-4-2
-----------------------	--------------

## Electrostatic discharge

Contact discharge	6 kV (Test Level 4)
Discharge in air	8 kV (Test Level 4)
Comments	Criterion A

## Electromagnetic HF field

Standards/regulations	EN 61000-4-3
-----------------------	--------------

## Electromagnetic HF field

Frequency range	80 MHz ... 1 GHz
Test field strength	10 V/m (Test Level 3)
Frequency range	1 GHz ... 2 GHz
Test field strength	10 V/m (Test Level 3)
Frequency range	2 GHz ... 6 GHz
Test field strength	10 V/m (Test Level 3)
Comments	Criterion A

## Fast transients (burst)

Standards/regulations	EN 61000-4-4
-----------------------	--------------

## Fast transients (burst)

Input	4 kV (Test Level 4 - asymmetrical)
Output	2 kV (Test Level 3 - asymmetrical)
Signal	2 kV (Test Level 4 - asymmetrical)
Comments	Criterion A

## Surge voltage load (surge)

Standards/regulations	EN 61000-4-5
-----------------------	--------------

## Surge voltage load (surge)

Input	2 kV (Test Level 4 - symmetrical)
	4 kV (Test Level 4 - asymmetrical)
Output	1 kV (Test Level 3 - symmetrical)
	2 kV (Test Level 3 - asymmetrical)
Signal	1 kV (Test Level 2 - asymmetrical)
Comments	Criterion A

## Conducted interference

Standards/regulations	EN 61000-4-6
-----------------------	--------------

## Conducted interference

Input/output/signal	asymmetrical
---------------------	--------------

# TRIO-PS-2G/1AC/48DC/5 - Power supply



2903159

<https://www.phoenixcontact.com/us/products/2903159>

Frequency range	0.15 MHz ... 80 MHz
Comments	Criterion A
Voltage	10 V (Test Level 3)

## Voltage dips

Standards/regulations	EN 61000-4-11
Voltage	230 V AC
Frequency	50 Hz
Voltage dip	70 %
Number of periods	25 periods
Additional text	Test Level 2
Comments	Criterion A
Voltage dip	40 %
Number of periods	10 periods
Additional text	Test Level 2
Comments	Criterion A
Voltage dip	0 %
Number of periods	1 period
Additional text	Test Level 2
Comments	Criterion A

## Emitted interference

Standards/regulations	EN 61000-6-3
Radio interference voltage in acc. with EN 55011	EN 55011 (EN 55022) Class B, area of application: Industry and residential
Emitted radio interference in acc. with EN 55011	EN 55011 (EN 55022) Class B, area of application: Industry and residential

## Criteria

Criterion A	Normal operating behavior within the specified limits.
Criterion B	Temporary impairment to operational behavior that is corrected by the device itself.
Criterion C	Temporary adverse effects on the operating behavior, which the device corrects automatically or which can be restored by actuating the operating elements.

# TRIO-PS-2G/1AC/48DC/5 - Power supply



2903159

<https://www.phoenixcontact.com/us/products/2903159>

## Drawings

Block diagram

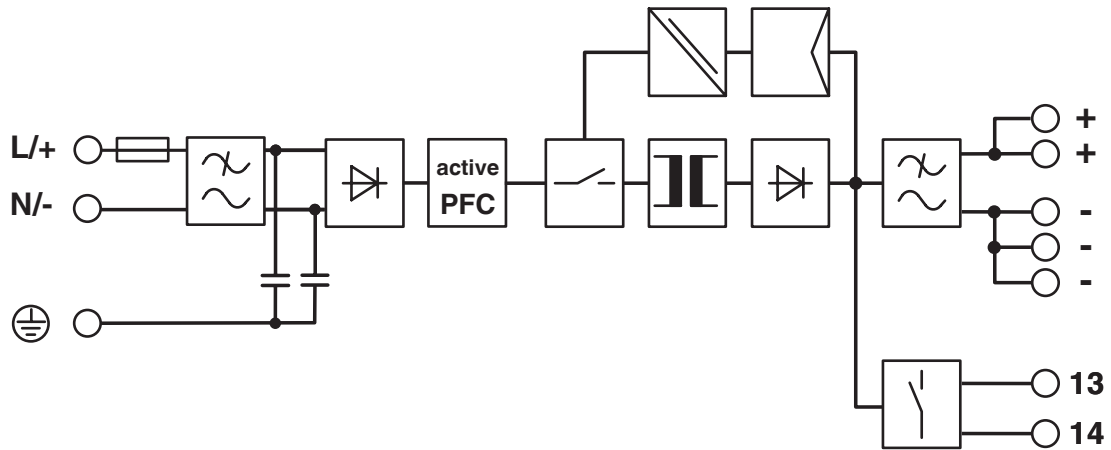

# TRIO-PS-2G/1AC/48DC/5 - Power supply



2903159

<https://www.phoenixcontact.com/us/products/2903159>

## Approvals

To download certificates, visit the product detail page: <https://www.phoenixcontact.com/us/products/2903159>



**cUL Recognized**  
Approval ID: E211944



**UL Recognized**  
Approval ID: E211944



**EAC**  
Approval ID: RU S-DE.BL08.W.00764



**UL Listed**  
Approval ID: E123528



**cUL Listed**  
Approval ID: E123528



**EAC**  
Approval ID: RU S-DE.BL08.W.00764



**IECEE CB Scheme**  
Approval ID: DE/PTZ/0036/A1



**UL Recognized**  
Approval ID: E211944



**IECEE CB Scheme**  
Approval ID: DE/PTZ/0036/A1



**cUL Recognized**  
Approval ID: E211944



**cUL Listed**  
Approval ID: E123528

# TRIO-PS-2G/1AC/48DC/5 - Power supply



2903159

<https://www.phoenixcontact.com/us/products/2903159>



**UL Listed**

Approval ID: E123528



**EAC**

Approval ID: RU S-DE.BL08.W.00764



**EAC**

Approval ID: RU S-DE.BL08.W.00764



**cUL Listed**

Approval ID: E199827



**UL Listed**

Approval ID: E199827



**UL Listed**

Approval ID: E199827



**cUL Listed**

Approval ID: E199827

# TRIO-PS-2G/1AC/48DC/5 - Power supply



2903159

<https://www.phoenixcontact.com/us/products/2903159>

## Classifications

### ECLASS

ECLASS-13.0	27040701
ECLASS-15.0	27040701

### ETIM

ETIM 10.0	EC002540
-----------	----------

### UNSPSC

UNSPSC 21.0	39121000
-------------	----------

# TRIO-PS-2G/1AC/48DC/5 - Power supply



2903159

<https://www.phoenixcontact.com/us/products/2903159>

## Environmental product compliance

### EU RoHS

Fulfills EU RoHS substance requirements	Yes
Exemption	7(a), 7(c)-I

### China RoHS

Environment friendly use period (EFUP)	EFUP-25
	An article-related China RoHS declaration table can be found in the download area for the respective article under "Manufacturer declaration". For all articles with EFUP-E, no China RoHS declaration table issued and required.

### EU REACH SVHC

REACH candidate substance (CAS No.)	Diboron trioxide(CAS: 1303-86-2)
	Lead monoxide (lead oxide)(CAS: 1317-36-8)
	Lead(CAS: 7439-92-1)
	6,6'-di-tert-butyl-2,2'-methylenedi-p-cresol(CAS: 119-47-1)
SCIP	70efb65d-8433-4e60-ae61-bedfb7825cfc

### EF3.1 Climate Change

CO2e kg	14.62 kg CO2e
---------	---------------

Phoenix Contact 2026 © - all rights reserved

<https://www.phoenixcontact.com>

Phoenix Contact USA

586 Fulling Mill Road

Middletown, PA 17057, United States

(+717) 944-1300

[info@phoenixcon.com](mailto:info@phoenixcon.com)