

TRIO-PS-2G/1AC/12DC/10 - Power supply



2903158

<https://www.phoenixcontact.com/us/products/2903158>

Please be informed that the data shown in this PDF document is generated from our online catalog. Please find the complete data in the user documentation. Our general terms of use for downloads are valid.



Primary-switched TRIO POWER power supply with push-in connection for DIN rail mounting, input: 1-phase, output: 12 V DC/10 A

Product description

TRIO POWER power supplies with standard functionality

The TRIO POWER power supply range with push-in connection has been perfected for use in machine building. All functions and the space-saving design of the single and three-phase modules are optimally tailored to the stringent requirements. Under challenging ambient conditions, the power supply units, which feature an extremely robust electrical and mechanical design, ensure the reliable supply of all loads.

Your advantages

- Save time and costs, thanks to the Push-in connection and narrow design
- Increase system availability, thanks to dynamic boost with 150 % of the nominal current for 5 seconds
- Maximum flexibility due to the wide temperature range from -25°C to +70°C and device startup at -40°C
- Electrically robust, thanks to high electric strength
- Mechanically robust, thanks to high vibration and shock resistance

Commercial data

Item number	2903158
Packing unit	1 pc
Minimum order quantity	1 pc
Sales key	CM12
Product key	CMPO12
GTIN	4055626255460
Weight per piece (including packing)	480 g
Weight per piece (excluding packing)	434.01 g
Customs tariff number	85044095
Country of origin	CN

Technical data

Input data

AC operation

Network type	Star network
Nominal input voltage range	100 V AC ... 240 V AC
Input voltage range	100 V AC ... 240 V AC -15 % ... +10 %
Input voltage range AC	85 V AC ... 264 V AC
Electric strength, max.	≤ 300 V AC 15 s
Typical national grid voltage	120 V AC
	230 V AC
Voltage type of supply voltage	AC
Inrush current	≤ 30 A (typical)
Inrush current integral (I ² t)	< 1.5 A ² s
Inrush current limitation	typ. 30 A (after 1 ms)
AC frequency range	50 Hz ... 60 Hz ±10 %
Mains buffering time	typ. 20 ms (120 V AC)
	typ. 20 ms (230 V AC)
Current consumption	2.2 A (100 V AC)
	1.9 A (120 V AC)
	1.1 A (230 V AC)
	1.1 A (240 V AC)
Nominal power consumption	254.7 VA
Protective circuit	Transient surge protection; Varistor
Power factor (cos phi)	0.53
Typical response time	< 1 s
Input fuse	6.3 A Fast blow (internal (device protection))
Recommended breaker for input protection	6 A ... 16 A (Characteristics B, C, D, K)
Discharge current to PE	< 0.25 mA

DC operation

Nominal input voltage range	122 V DC ... 250 V DC
Input voltage range	122 V DC ... 275 V DC
Extended input voltage range in operation	> 106 V AC
Derating	< 99 V DC (2 %/V)
Shut-down voltage	105 V DC
Voltage type of supply voltage	DC
Mains buffering time	> 100 ms (230 V AC)
Current consumption	1.4 A (122 V DC)
	0.6 A (250 V DC)

Output data

Efficiency	typ. 87.5 % (120 V AC)
------------	------------------------

TRIO-PS-2G/1AC/12DC/10 - Power supply



2903158

<https://www.phoenixcontact.com/us/products/2903158>

	typ. 88.7 % (230 V AC)
Output characteristic	U/I with dynamic load reserve
Nominal output voltage	12 V DC \pm 1 %
Setting range of the output voltage (U_{Set})	12 V DC ... 18 V DC (> 12 V DC, constant capacity restricted)
Nominal output current (I_N)	10 A
Dynamic Boost ($I_{Dyn.Boost}$)	15 A (5 s)
Derating	> 60 °C ... 70 °C (2.5 %/K)
Feedback voltage resistance	< 25 V
Protection against overvoltage at the output (OVP)	\leq 22 V DC
Control deviation	< 1 % (change in load, static 10 % ... 90 %)
	< 3 % (Dynamic load change 10 % ... 90 %, 10 Hz)
	< 0.1 % (change in input voltage \pm 10 %)
Residual ripple	< 50 mV _{PP} (with nominal values)
Output power	120 W
	180 W (5 s)
Maximum no-load power dissipation	< 1 W (230 V)
Power loss nominal load max.	< 15 W (230 V)
Rise time	\leq 10 ms (U_{OUT} (10 % ... 90 %))
Connection in parallel	yes, for redundancy and increased capacity
Connection in series	yes

Signal: DC OK

Maximum switching voltage	30 V AC/DC
Continuous load current	100 mA

Connection data

Input

Connection method	Push-in connection
Conductor cross-section, rigid min.	0.2 mm ²
Conductor cross-section, rigid max.	4 mm ²
Conductor cross-section flexible min.	0.2 mm ²
Conductor cross-section flexible max.	2.5 mm ²
Conductor cross-section AWG min.	24
Conductor cross-section AWG max.	12
Stripping length	10 mm

Output

Connection method	Push-in connection
Conductor cross-section, rigid min.	0.2 mm ²
Conductor cross-section, rigid max.	4 mm ²
Conductor cross-section flexible min.	0.2 mm ²
Conductor cross-section flexible max.	2.5 mm ²
Conductor cross-section AWG min.	24
Conductor cross-section AWG max.	12

TRIO-PS-2G/1AC/12DC/10 - Power supply



2903158

<https://www.phoenixcontact.com/us/products/2903158>

Stripping length	8 mm
------------------	------

Signal

Connection method	Push-in connection
Conductor cross-section, rigid min.	0.2 mm ²
Conductor cross-section, rigid max.	1.5 mm ²
Conductor cross-section flexible min.	0.2 mm ²
Conductor cross-section flexible max.	1.5 mm ²
Conductor cross-section AWG min.	24
Conductor cross-section AWG max.	16
Stripping length	8 mm

Signaling

Types of signaling	LED
	Floating signal contact

Signal output: LED status indicator

Signalization designation	DC OK
Status display	"DC OK" LED
Color	green

Electrical properties

Number of phases	1
Insulation voltage input/output	3 kV AC (type test)
	1.5 kV AC (routine test)

Product properties

Product type	Power supply
Product family	TRIO POWER
MTBF (IEC 61709, SN 29500)	> (25 °C)
	> 1700000 h (40 °C)
	60 °C

Insulation characteristics

Protection class	II (in closed control cabinet)
Overvoltage category (EN 62368-1)	II (≤ 2000 m)
Degree of pollution	2

Dimensions

Width	35 mm
Height	130 mm
Depth	115 mm

Installation dimensions

Installation distance right/left	0 mm / 0 mm
Installation distance top/bottom	50 mm / 50 mm

TRIO-PS-2G/1AC/12DC/10 - Power supply



2903158

<https://www.phoenixcontact.com/us/products/2903158>

Mounting

Mounting type	DIN rail mounting
Assembly note	alignable: horizontally 0 mm ($\leq 40\text{ }^{\circ}\text{C}$) 10 mm ($\leq 70\text{ }^{\circ}\text{C}$), vertically 50 mm
Mounting position	horizontal DIN rail NS 35, EN 60715
With protective coating	no

Material specifications

Flammability rating according to UL 94 (housing / terminal blocks)	V0
Housing material	Plastic
Housing material	PC
Type of housing	Polycarbonate
Hood version	Polycarbonate

Environmental and real-life conditions

Ambient conditions

Degree of protection	IP20
Ambient temperature (operation)	-25 °C ... 70 °C (> 60 °C Derating: 2,5 %/K)
Ambient temperature (storage/transport)	-40 °C ... 85 °C
Ambient temperature (start-up type tested)	-40 °C
Maximum altitude	$\leq 5000\text{ m}$ (> 2000 m, Derating: 10 %/1000 m)
Climatic class	3K3 (in acc. with EN 60721)
Max. permissible relative humidity (operation)	$\leq 95\text{ }%$ (at 25 °C, non-condensing)
Shock	18 ms, 30g, in each space direction (according to IEC 60068-2-27)
Vibration (operation)	< 15 Hz, amplitude $\pm 2.5\text{ mm}$ (according to IEC 60068-2-6) 15 Hz ... 150 Hz, 4g, 90 min.

Standards and regulations

Rail applications	EN 50121-4
Standard – Limitation of mains harmonic currents	EN 61000-3-2
Standard - Electrical safety	IEC 62368-1 (SELV)
Standard – Safety extra-low voltage	IEC 62368-1 (SELV) und EN 60204-1 (PELV)
Standard - Safe isolation	DIN VDE 0100-410
Standard - Safety of transformers	EN 61558-2-16 (air clearances and creepage distances only)

Approvals

UL approvals	UL Listed UL 508 UL/C-UL Recognized UL 60950-1
--------------	---

Conformity/Approvals

SIL in accordance with IEC 61508	0
----------------------------------	---

EMC data

TRIO-PS-2G/1AC/12DC/10 - Power supply



2903158

<https://www.phoenixcontact.com/us/products/2903158>

Electromagnetic compatibility	Conformance with EMC Directive 2014/30/EU
Low Voltage Directive	Conformance with Low Voltage Directive 2014/35/EC
EMC requirements for noise emission	EN 61000-6-3
	EN 61000-6-4
EMC requirements for noise immunity	EN 61000-6-1
	EN 61000-6-2

Noise emission

Standards/regulations	EN 55011 (EN 55022)
-----------------------	---------------------

Electrostatic discharge

Standards/regulations	EN 61000-4-2
-----------------------	--------------

Electrostatic discharge

Contact discharge	6 kV (Test Level 3)
Discharge in air	8 kV (Test Level 3)
Comments	Criterion A

Electromagnetic HF field

Standards/regulations	EN 61000-4-3
-----------------------	--------------

Electromagnetic HF field

Frequency range	80 MHz ... 6 GHz
Test field strength	10 V/m (Test Level 3)
Frequency range	80 MHz ... 6 GHz
Test field strength	10 V/m (Test Level 3)
Frequency range	80 MHz ... 6 GHz
Test field strength	10 V/m (Test Level 3)
Comments	Criterion A

Fast transients (burst)

Standards/regulations	EN 61000-4-4
-----------------------	--------------

Fast transients (burst)

Input	4 kV (Test Level 3 - asymmetrical)
Output	2 kV (Test Level 3 - asymmetrical)
Signal	2 kV (Test Level 3 - asymmetrical)
Comments	Criterion A

Surge voltage load (surge)

Standards/regulations	EN 61000-4-5
-----------------------	--------------

Surge voltage load (surge)

Input	3 kV (Test Level 4 - symmetrical)
	6 kV (Test Level 4 - asymmetrical)
Output	1 kV (Test Level 3 - symmetrical)
	2 kV (Test Level 3 - asymmetrical)
Signal	1 kV (Test Level 2 - asymmetrical)

TRIO-PS-2G/1AC/12DC/10 - Power supply



2903158

<https://www.phoenixcontact.com/us/products/2903158>

Comments	Criterion A
Conducted interference	
Standards/regulations	EN 61000-4-6
Conducted interference	
Input/Output	asymmetrical
Frequency range	0.15 MHz ... 80 MHz
Comments	Criterion A
Voltage	10 V (Test Level 3)
Voltage dips	
Standards/regulations	EN 61000-4-11
Voltage	230 V AC
Frequency	50 Hz
Emitted interference	
Standards/regulations	EN 61000-6-3
Radio interference voltage in acc. with EN 55011	EN 55011 (EN 55022) Class B, area of application: Industry and residential
Emitted radio interference in acc. with EN 55011	EN 55011 (EN 55022) Class B, area of application: Industry and residential
Criteria	
Criterion A	Normal operating behavior within the specified limits.
Criterion B	Temporary impairment to operational behavior that is corrected by the device itself.

TRIO-PS-2G/1AC/12DC/10 - Power supply



2903158

<https://www.phoenixcontact.com/us/products/2903158>

Drawings

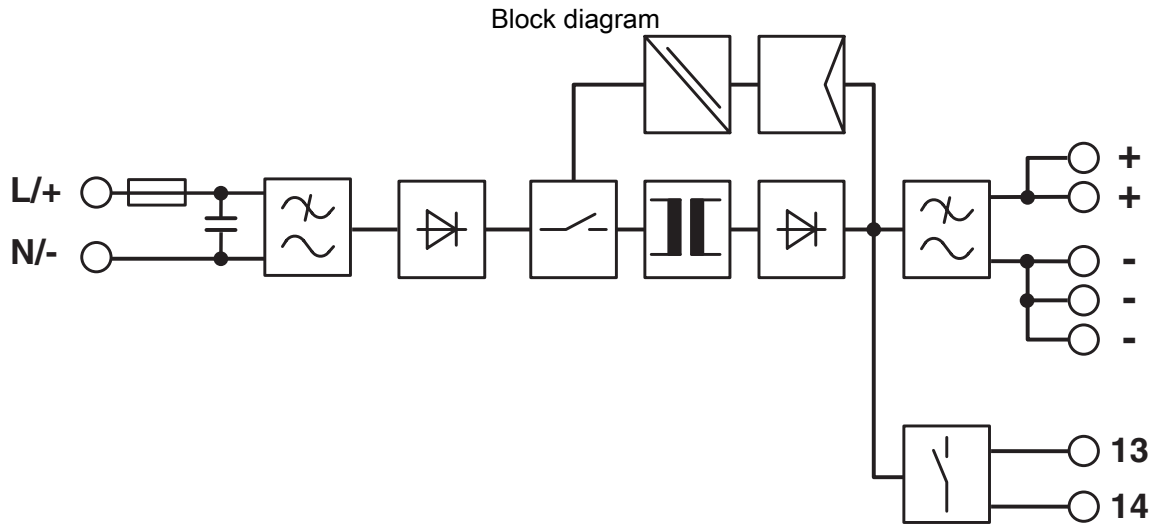

TRIO-PS-2G/1AC/12DC/10 - Power supply



2903158

<https://www.phoenixcontact.com/us/products/2903158>

Approvals

To download certificates, visit the product detail page: <https://www.phoenixcontact.com/us/products/2903158>



cUL Recognized
Approval ID: E211944



UL Recognized
Approval ID: E211944



EAC
Approval ID: RU S-DE.BL08.W.00764



UL Listed
Approval ID: E123528



cUL Listed
Approval ID: E123528



EAC
Approval ID: RU S-DE.BL08.W.00764



IECEE CB Scheme
Approval ID: DE/PTZ/0036/A1



cUL Listed
Approval ID: E199827



UL Listed
Approval ID: FILE E 199827

TRIO-PS-2G/1AC/12DC/10 - Power supply



2903158

<https://www.phoenixcontact.com/us/products/2903158>

Classifications

ECLASS

ECLASS-13.0	27040701
ECLASS-15.0	27040701

ETIM

ETIM 10.0	EC002540
-----------	----------

UNSPSC

UNSPSC 21.0	39121000
-------------	----------

TRIO-PS-2G/1AC/12DC/10 - Power supply



2903158

<https://www.phoenixcontact.com/us/products/2903158>

Environmental product compliance

EU RoHS

Fulfills EU RoHS substance requirements	Yes
Exemption	7(a), 7(c)-I

China RoHS

Environment friendly use period (EFUP)	EFUP-25
	An article-related China RoHS declaration table can be found in the download area for the respective article under "Manufacturer declaration". For all articles with EFUP-E, no China RoHS declaration table issued and required.

EU REACH SVHC

REACH candidate substance (CAS No.)	Diboron trioxide(CAS: 1303-86-2)
	Lead monoxide (lead oxide)(CAS: 1317-36-8)
	Lead(CAS: 7439-92-1)
SCIP	bd51fa7a-c91a-4203-bbef-726a9746cdb7

EF3.1 Climate Change

CO2e kg	10.68 kg CO2e
---------	---------------

Phoenix Contact 2026 © - all rights reserved

<https://www.phoenixcontact.com>

Phoenix Contact USA
586 Fulling Mill Road
Middletown, PA 17057, United States
(+717) 944-1300
info@phoenixcon.com