

# TRIO-PS-2G/1AC/12DC/5/C2LPS - Power supply



2903157

<https://www.phoenixcontact.com/us/products/2903157>

Please be informed that the data shown in this PDF document is generated from our online catalog. Please find the complete data in the user documentation. Our general terms of use for downloads are valid.



Primary-switched TRIO POWER power supply with push-in connection for DIN rail mounting, input: 1-phase, output: 12 V DC/5 A C2LPS

## Product description

TRIO POWER power supplies with standard functionality

The TRIO POWER power supply range with push-in connection has been perfected for use in machine building. All functions and the space-saving design of the single and three-phase modules are optimally tailored to the stringent requirements. Under challenging ambient conditions, the power supply units, which feature an extremely robust electrical and mechanical design, ensure the reliable supply of all loads.

## Your advantages

- Save time and costs, thanks to the Push-in connection and narrow design
- Increase system availability, thanks to dynamic boost with 150 % of the nominal current for 5 seconds
- Maximum flexibility due to the wide temperature range from -25°C to +70°C and device startup at -40°C
- Electrically robust, thanks to high electric strength
- Mechanically robust, thanks to high vibration and shock resistance

## Commercial data

Item number	2903157
Packing unit	1 pc
Minimum order quantity	1 pc
Sales key	CM12
Product key	CMPO12
GTIN	4055626248486
Weight per piece (including packing)	376.1 g
Weight per piece (excluding packing)	325 g
Customs tariff number	85044095
Country of origin	CN

# TRIO-PS-2G/1AC/12DC/5/C2LPS - Power supply



2903157

<https://www.phoenixcontact.com/us/products/2903157>

## Technical data

### Input data

#### AC operation

Network type	Star network
Nominal input voltage range	100 V AC ... 240 V AC
Input voltage range	100 V AC ... 240 V AC -15 % ... +10 %
Input voltage range AC	85 V AC ... 264 V AC
Electric strength, max.	≤ 300 V AC 15 s
Typical national grid voltage	120 V AC 230 V AC
Voltage type of supply voltage	AC
Inrush current	≤ 25 A (typical)
Inrush current integral ( $I^2t$ )	< 0.6 A <sup>2</sup> s
Inrush current limitation	typ. 25 A (after 1 ms)
AC frequency range	50 Hz ... 60 Hz ±10 %
Mains buffering time	typ. 20 ms (120 V AC) typ. 110 ms (230 V AC)
Current consumption	1.1 A (100 V AC) 1 A (120 V AC) 0.6 A (230 V AC) 0.6 A (240 V AC)
Nominal power consumption	137.3 VA
Protective circuit	Transient surge protection; Varistor
Power factor (cos phi)	0.51
Typical response time	< 1 s
Input fuse	6.3 A Slow-blow
Recommended breaker for input protection	6 A ... 16 A (Characteristics B, C, D, K)
Discharge current to PE	< 0.25 mA

#### DC operation

Nominal input voltage range	110 V DC ... 250 V DC
Input voltage range	99 V DC ... 275 V DC
Switch-on voltage	≥ 85 V DC
Shut-down voltage	< 80 V DC
Voltage type of supply voltage	DC
Current consumption	0.7 A (110 V DC) 0.3 A (250 V DC)

### Output data

Efficiency	> 86 % (for 230 V AC and nominal values)
Output characteristic	U/I with dynamic load reserve
Nominal output voltage	12 V DC ±1 %

# TRIO-PS-2G/1AC/12DC/5/C2LPS - Power supply



2903157

<https://www.phoenixcontact.com/us/products/2903157>

Setting range of the output voltage ( $U_{Set}$ )	12 V DC ... 18 V DC (> 12 V DC, constant capacity restricted)
Nominal output current ( $I_N$ )	5 A
Derating	> 60 °C ... 70 °C (2.5 %/K)
Feedback voltage resistance	< 25 V
Protection against overvoltage at the output (OVP)	≤ 22 V DC
Control deviation	< 1 % (change in load, static 10 % ... 90 %)
	< 3 % (Dynamic load change 10 % ... 90 %, 10 Hz)
	< 0.1 % (change in input voltage ±10 %)
Residual ripple	< 50 mV <sub>PP</sub> (with nominal values)
Output power	60 W
Maximum no-load power dissipation	< 1 W (230 V)
Power loss nominal load max.	< 10 W (230 V)
Rise time	≤ 10 ms ( $U_{OUT}$ (10 % ... 90 %))
Connection in parallel	yes, for redundancy and increased capacity
Connection in series	yes

Signal: DC OK

Maximum switching voltage	30 V AC/DC
Continuous load current	100 mA

## Connection data

### Input

Connection method	Push-in connection
Conductor cross-section, rigid min.	0.2 mm <sup>2</sup>
Conductor cross-section, rigid max.	4 mm <sup>2</sup>
Conductor cross-section flexible min.	0.2 mm <sup>2</sup>
Conductor cross-section flexible max.	2.5 mm <sup>2</sup>
Conductor cross-section AWG min.	24
Conductor cross-section AWG max.	12
Stripping length	10 mm

### Output

Connection method	Push-in connection
Conductor cross-section, rigid min.	0.2 mm <sup>2</sup>
Conductor cross-section, rigid max.	4 mm <sup>2</sup>
Conductor cross-section flexible min.	0.2 mm <sup>2</sup>
Conductor cross-section flexible max.	2.5 mm <sup>2</sup>
Conductor cross-section AWG min.	24
Conductor cross-section AWG max.	12
Stripping length	8 mm

### Signal

Connection method	Push-in connection
Conductor cross-section, rigid min.	0.2 mm <sup>2</sup>
Conductor cross-section, rigid max.	1.5 mm <sup>2</sup>

# TRIO-PS-2G/1AC/12DC/5/C2LPS - Power supply



2903157

<https://www.phoenixcontact.com/us/products/2903157>

Conductor cross-section flexible min.	0.2 mm <sup>2</sup>
Conductor cross-section flexible max.	1.5 mm <sup>2</sup>
Conductor cross-section AWG min.	24
Conductor cross-section AWG max.	16
Stripping length	8 mm

## Signaling

Types of signaling	LED
	Floating signal contact

Signal output: LED status indicator

Signalization designation	DC OK
Status display	"DC OK" LED
Color	green

## Electrical properties

Number of phases	1
Insulation voltage input/output	3 kV AC (type test)
	1.5 kV AC (routine test)

## Product properties

Product type	Power supply
Product family	TRIO POWER
MTBF (IEC 61709, SN 29500)	25 °C
	> 2900000 h (40 °C)
	60 °C

Insulation characteristics

Protection class	II (in closed control cabinet)
Overvoltage category (EN 62368-1)	II (≤ 2000 m)
Degree of pollution	2

## Dimensions

Width	30 mm
Height	130 mm
Depth	115 mm

Installation dimensions

Installation distance right/left	0 mm / 0 mm
Installation distance top/bottom	50 mm / 50 mm

## Mounting

Mounting type	DIN rail mounting
Assembly note	alignable: horizontally 0 mm (≤ 40 °C) 10 mm (≤ 70 °C), vertically 50 mm
Mounting position	horizontal DIN rail NS 35, EN 60715

# TRIO-PS-2G/1AC/12DC/5/C2LPS - Power supply



2903157

<https://www.phoenixcontact.com/us/products/2903157>

With protective coating	no
-------------------------	----

## Material specifications

Flammability rating according to UL 94 (housing / terminal blocks)	V0
Housing material	Plastic
Housing material	PC
Type of housing	Polycarbonate
Hood version	Polycarbonate

## Environmental and real-life conditions

### Ambient conditions

Degree of protection	IP20
Ambient temperature (operation)	-25 °C ... 70 °C (> 60 °C Derating: 2,5 %/K)
Ambient temperature (storage/transport)	-40 °C ... 85 °C
Ambient temperature (start-up type tested)	-40 °C
Maximum altitude	≤ 5000 m (> 2000 m, Derating: 10 %/1000 m)
Climatic class	3K3 (in acc. with EN 60721)
Max. permissible relative humidity (operation)	≤ 95 % (at 25 °C, non-condensing)
Shock	18 ms, 30g, in each space direction (according to IEC 60068-2-27)
Vibration (operation)	< 15 Hz, amplitude ±2.5 mm (according to IEC 60068-2-6) 15 Hz ... 150 Hz, 4g, 90 min.

## Standards and regulations

Rail applications	EN 50121-4
Standard – Limitation of mains harmonic currents	EN 61000-3-2
Standard - Electrical safety	IEC 62368-1 (SELV)
Standard – Safety extra-low voltage	IEC 62368-1 (SELV) und EN 60204-1 (PELV)
Standard - Safe isolation	DIN VDE 0100-410
Standard - Safety of transformers	EN 61558-2-16 (air clearances and creepage distances only)

## Approvals

UL approvals	UL Listed UL 508
	UL/C-UL Recognized UL 60950-1
	NEC Class 2 as per UL 1310

### Conformity/Approvals

SIL in accordance with IEC 61508	0
----------------------------------	---

## EMC data

Electromagnetic compatibility	Conformance with EMC Directive 2014/30/EU
Low Voltage Directive	Conformance with Low Voltage Directive 2014/35/EC
EMC requirements for noise emission	EN 61000-6-3
	EN 61000-6-4

# TRIO-PS-2G/1AC/12DC/5/C2LPS - Power supply



2903157

<https://www.phoenixcontact.com/us/products/2903157>

EMC requirements for noise immunity	EN 61000-6-1
	EN 61000-6-2
Noise emission	
Standards/regulations	EN 55011 (EN 55022)
Electrostatic discharge	
Standards/regulations	EN 61000-4-2
Electrostatic discharge	
Contact discharge	6 kV (Test Level 3)
Discharge in air	8 kV (Test Level 3)
Comments	Criterion A
Electromagnetic HF field	
Standards/regulations	EN 61000-4-3
Electromagnetic HF field	
Frequency range	80 MHz ... 3 GHz
Test field strength	10 V/m (Test Level 3)
Frequency range	80 MHz ... 3 GHz
Test field strength	10 V/m (Test Level 3)
Frequency range	80 MHz ... 3 GHz
Test field strength	10 V/m (Test Level 3)
Comments	Criterion A
Fast transients (burst)	
Standards/regulations	EN 61000-4-4
Fast transients (burst)	
Input	4 kV (Test Level 3 - asymmetrical)
Output	2 kV (Test Level 3 - asymmetrical)
Signal	2 kV (Test Level 3 - asymmetrical)
Comments	Criterion A
Surge voltage load (surge)	
Standards/regulations	EN 61000-4-5
Surge voltage load (surge)	
Input	3 kV (Test Level 4 - symmetrical)
	6 kV (Test Level 4 - asymmetrical)
Output	1 kV (Test Level 3 - symmetrical)
	2 kV (Test Level 3 - asymmetrical)
Signal	1 kV (Test Level 2 - asymmetrical)
Comments	Criterion A
Conducted interference	
Standards/regulations	EN 61000-4-6

# TRIO-PS-2G/1AC/12DC/5/C2LPS - Power supply



2903157

<https://www.phoenixcontact.com/us/products/2903157>

## Conducted interference

Input/Output	asymmetrical
Frequency range	0.15 MHz ... 80 MHz
Comments	Criterion A
Voltage	10 V (Test Level 3)

## Voltage dips

Standards/regulations	EN 61000-4-11
Voltage	230 V AC
Frequency	50 Hz

## Emitted interference

Standards/regulations	EN 61000-6-3
Radio interference voltage in acc. with EN 55011	EN 55011 (EN 55022) Class B, area of application: Industry and residential
Emitted radio interference in acc. with EN 55011	EN 55011 (EN 55022) Class B, area of application: Industry and residential

## Criteria

Criterion A	Normal operating behavior within the specified limits.
Criterion B	Temporary impairment to operational behavior that is corrected by the device itself.

# TRIO-PS-2G/1AC/12DC/5/C2LPS - Power supply



2903157

<https://www.phoenixcontact.com/us/products/2903157>

## Drawings

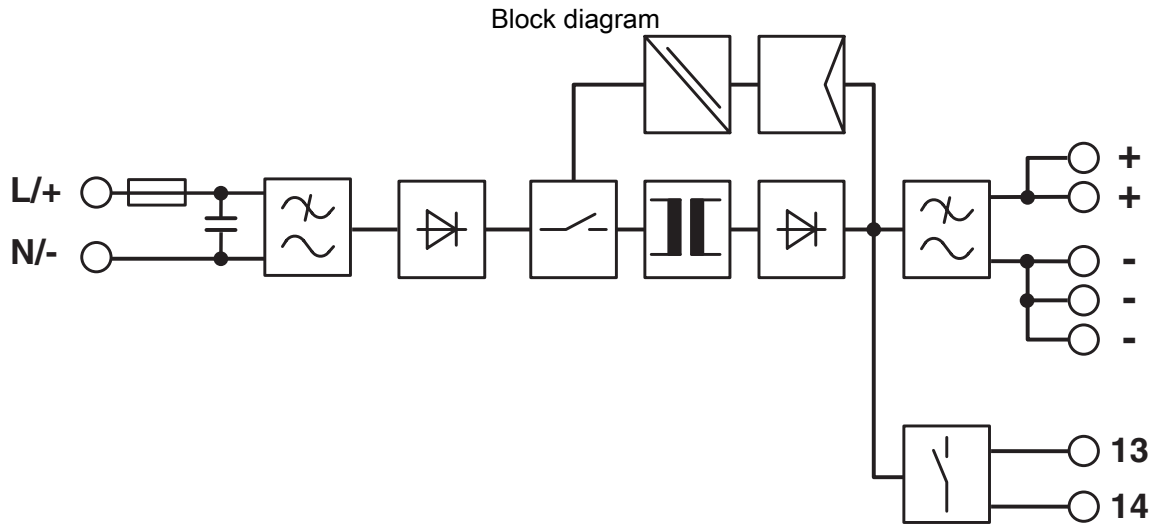

# TRIO-PS-2G/1AC/12DC/5/C2LPS - Power supply



2903157

<https://www.phoenixcontact.com/us/products/2903157>

## Approvals

To download certificates, visit the product detail page: <https://www.phoenixcontact.com/us/products/2903157>



**cUL Recognized**  
Approval ID: E211944



**UL Recognized**  
Approval ID: E211944



**IECEE CB Scheme**  
Approval ID: DK-50730-UL



**EAC**  
Approval ID: RU S-DE.BL08.W.00764



**UL Listed**  
Approval ID: E123528



**cUL Listed**  
Approval ID: E123528



**EAC**  
Approval ID: RU S-DE.BL08.W.00764



**IECEE CB Scheme**  
Approval ID: DE/PTZ/0036/A1



**cUL Listed**  
Approval ID: E199827



**UL Listed**  
Approval ID: E199827

# TRIO-PS-2G/1AC/12DC/5/C2LPS - Power supply



2903157

<https://www.phoenixcontact.com/us/products/2903157>

## Classifications

### ECLASS

ECLASS-13.0	27040701
ECLASS-15.0	27040701

### ETIM

ETIM 10.0	EC002540
-----------	----------

### UNSPSC

UNSPSC 21.0	39121000
-------------	----------

2903157

<https://www.phoenixcontact.com/us/products/2903157>

## Environmental product compliance

### EU RoHS

Fulfills EU RoHS substance requirements	Yes
Exemption	7(a), 7(c)-I

### China RoHS

Environment friendly use period (EFUP)	EFUP-25
	An article-related China RoHS declaration table can be found in the download area for the respective article under "Manufacturer declaration". For all articles with EFUP-E, no China RoHS declaration table issued and required.

### EU REACH SVHC

REACH candidate substance (CAS No.)	Lead(CAS: 7439-92-1)
SCIP	3ee3194c-ae2a-4d3a-84d6-8021c08fc8e1

### EF3.1 Climate Change

CO2e kg	11 kg CO2e
---------	------------

Phoenix Contact 2026 © - all rights reserved  
<https://www.phoenixcontact.com>

Phoenix Contact USA  
586 Fulling Mill Road  
Middletown, PA 17057, United States  
(+717) 944-1300  
[info@phoenixcon.com](mailto:info@phoenixcon.com)