

DFLK 14/FKCT - Termination board



2903035

<https://www.phoenixcontact.com/us/products/2903035>

Please be informed that the data shown in this PDF document is generated from our online catalog. Please find the complete data in the user documentation. Our general terms of use for downloads are valid.



The VARIOFACE feed-through module implements a 1:1 connection between a push-in spring-cage connection and an IDC/FLK pin strip (2.54 mm, number of positions: 14).

Commercial data

Item number	2903035
Packing unit	1 pc
Note	Made to order (non-returnable)
Sales key	C422
Product key	DK21C1
GTIN	4046356709385
Weight per piece (including packing)	72.2 g
Weight per piece (excluding packing)	72.2 g
Customs tariff number	85369010
Country of origin	DE

Technical data

Product properties

Product type	Interface module
Product family	VARIOFACE
Number of positions	14

Insulation characteristics

Overvoltage category	II
Pollution degree	2

Electrical properties

Nominal voltage U_N	< 50 V AC
	60 V DC
Max. current carrying capacity per branch	1 A
Rated insulation voltage	63 V
Rated surge voltage	0.6 kV (Functional insulation)

Connection data

Field level

Connection method	Push-in spring connection
Stripping length	10 mm
Conductor cross-section rigid	0.2 mm ² ... 2.5 mm ²
Conductor cross-section flexible	0.2 mm ² ... 2.5 mm ²
Conductor cross-section AWG	24 ... 12

Controller level

Connection method	IDC/FLK pin strip
Number of connections	1
Number of positions	14
Pitch	2.54 mm

Signaling

Status display	no
Status display present	no

Dimensions

Item dimensions

Width	36.5 mm
Height	58.4 mm
Depth	60 mm

Material specifications

Color	green (RAL 6021)
-------	------------------

DFLK 14/FKCT - Termination board



2903035

<https://www.phoenixcontact.com/us/products/2903035>

Environmental and real-life conditions

Ambient conditions

Degree of protection	IP20
Ambient temperature (operation)	-20 °C ... 50 °C
Ambient temperature (storage/transport)	-20 °C ... 70 °C

Standards and regulations

Standards/regulations	DIN EN 50178
	IEC 60664

Mounting

Mounting type	Rear mounting
Mounting position	any

Notes

Notes on operation	For proper use, the specifications of the installation directive (see Downloads) must be observed. For applications or use with third-party products, the specifications, and the safety and warning instructions of the respective third-party manufacturer must also be met.
--------------------	--

DFLK 14/FKCT - Termination board



2903035

<https://www.phoenixcontact.com/us/products/2903035>

Drawings

Dimensional drawing

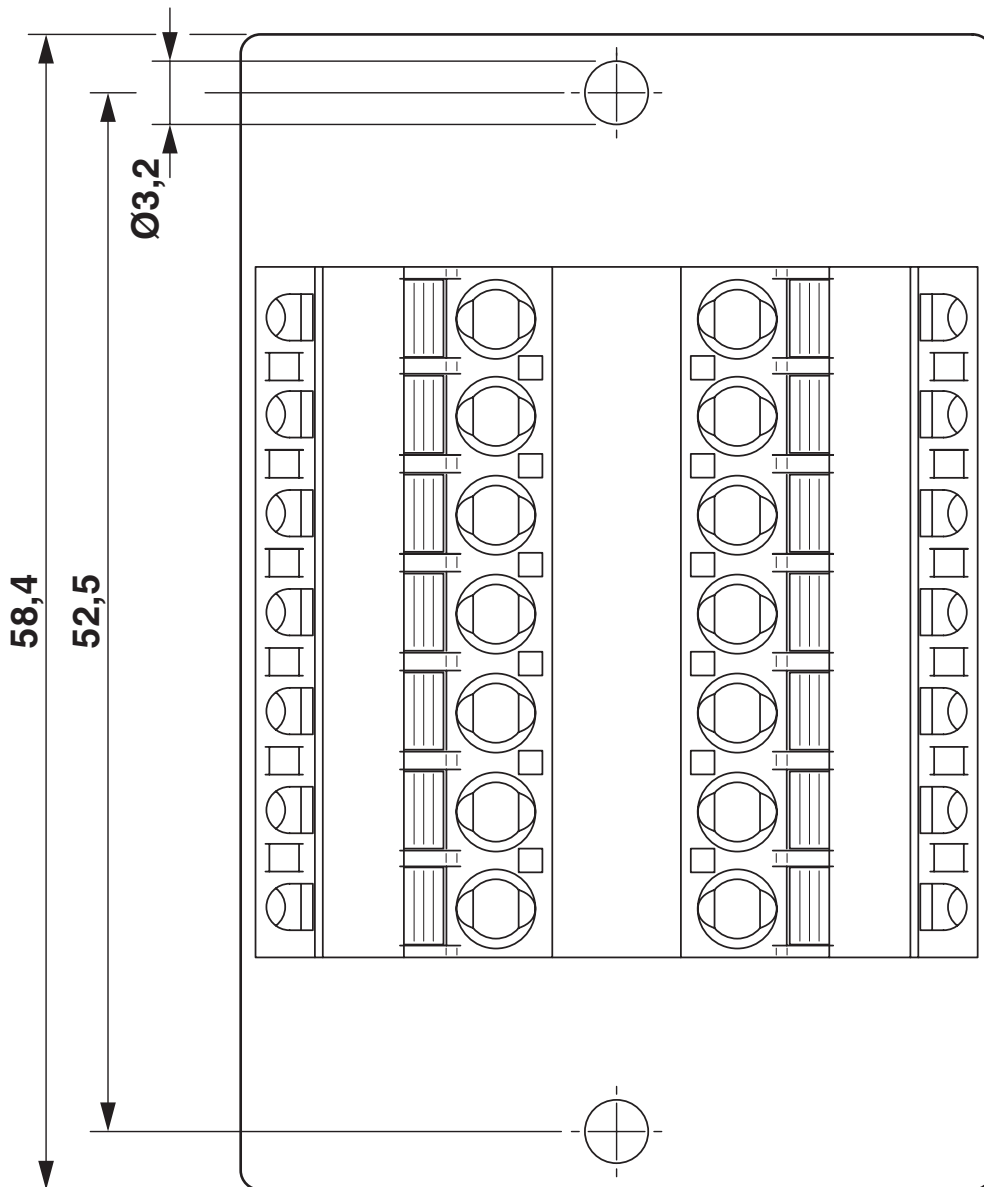

DFLK 14/FKCT - Termination board

2903035

<https://www.phoenixcontact.com/us/products/2903035>

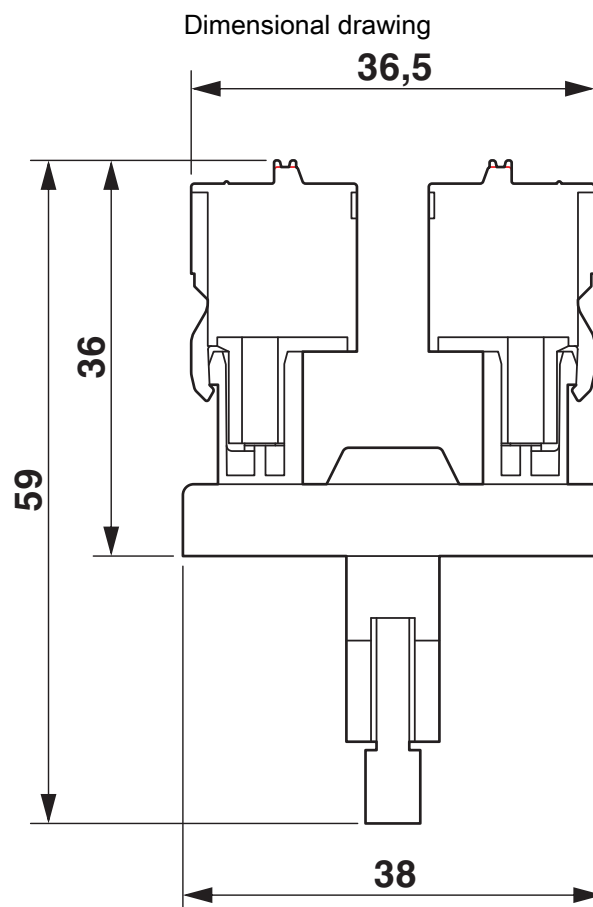
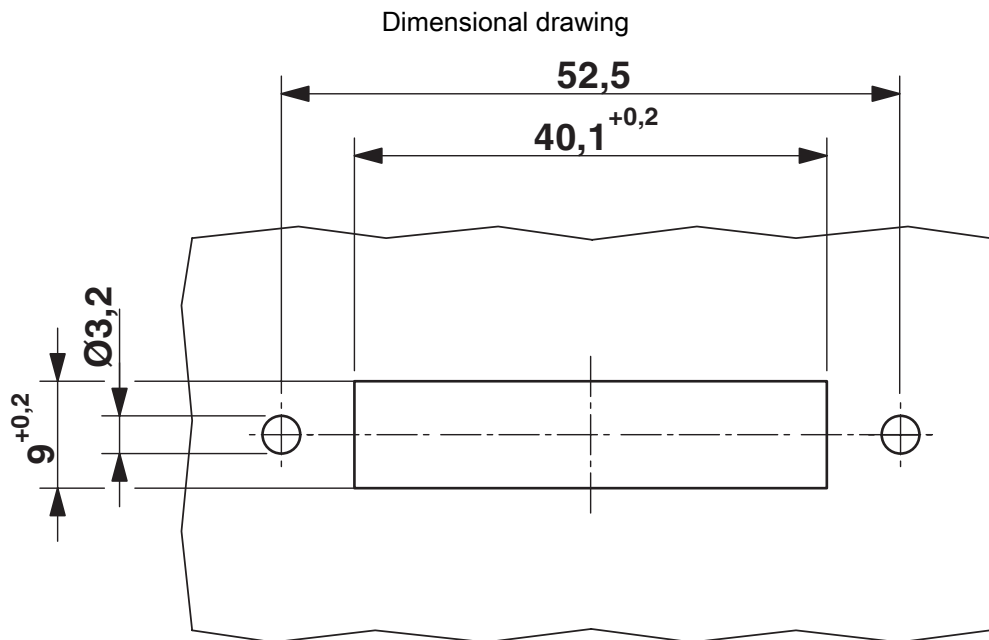

2903035

<https://www.phoenixcontact.com/us/products/2903035>

Environmental product compliance

EU RoHS

Fulfills EU RoHS substance requirements	Yes, No exemptions
---	--------------------

China RoHS

Environment friendly use period (EFUP)	EFUP-50
	An article-related China RoHS declaration table can be found in the download area for the respective article under "Manufacturer declaration". For all articles with EFUP-E, no China RoHS declaration table issued and required.

EU REACH SVHC

REACH candidate substance (CAS No.)	No substance above 0.1 wt%
-------------------------------------	----------------------------

Phoenix Contact 2026 © - all rights reserved

<https://www.phoenixcontact.com>

Phoenix Contact USA
586 Fulling Mill Road
Middletown, PA 17057, United States
(+717) 944-1300
info@phoenixcon.com