

ELR H3-ES-SC-230AC/500AC-0,6 - Hybrid motor starter



2900686

<https://www.phoenixcontact.com/us/products/2900686>

Please be informed that the data shown in this PDF document is generated from our online catalog. Please find the complete data in the user documentation. Our general terms of use for downloads are valid.



Hybrid motor starter for starting 3~ AC motors up to 550 V AC, with 230 V AC input, 0.6 A output current, and emergency stop function.

The figure shows the 9 A version

Your advantages

- 22.5 mm wide
- Safety level in accordance with IEC 61508-1: SIL 3, ISO 13849: PL e
- Reduction in wiring
- Long service life
- Space saving
- 3-phase loop bridges
- Low-wear switching

Commercial data

Item number	2900686
Packing unit	1 pc
Note	Made to order (non-returnable)
Sales key	NULL
Product key	DK7411
GTIN	4046356527750
Weight per piece (including packing)	282.6 g
Weight per piece (excluding packing)	223.15 g
Customs tariff number	85371099
Country of origin	DE

ELR H3-ES-SC-230AC/500AC-0,6 - Hybrid motor starter



2900686

<https://www.phoenixcontact.com/us/products/2900686>

Technical data

Product properties

Product type	Hybrid motor starters
Product family	CONTACTRON
Operating mode	100% operating factor

Insulation characteristics: Air clearances and creepage distances between the power circuits

Insulation	safe isolation
Overvoltage category	III
Degree of pollution	2

Electrical properties

Number of phases	3
Service life electrical	3×10^7 cycles
Reversing frequency	≤ 2 Hz
Maximum power dissipation	2.9 W
Minimum power dissipation	2.6 W
Coordination type	1

Air clearances and creepage distances between the power circuits

Rated insulation voltage	500 V
Rated surge voltage	6 kV

Supply

Rated control circuit supply voltage U_S	230 V AC
Control supply voltage range	92 V AC ... 253 V AC
Rated control supply current I_S	4 mA
Mains frequency	50/60 Hz
Protective circuit	Surge protection

Input data

Control

Rated actuating voltage U_C	230 V AC
Triggering voltage range	92 V AC ... 253 V AC
Mains frequency	50 Hz 60 Hz 50/60 Hz
Switching threshold	44 V AC ("0" signal) 85 V AC ("1" signal)
Switching level	< 5 V AC (For EMERGENCY STOP)
Typical turn-off time	< 70 ms

Output data

AC output

Rated operating voltage U_e	500 V AC
-------------------------------	----------

ELR H3-ES-SC-230AC/500AC-0,6 - Hybrid motor starter



2900686

<https://www.phoenixcontact.com/us/products/2900686>

Operating voltage range	42 V AC ... 550 V AC
Rated operating current I_e	0.6 A (AC-51)
	0.6 A (AC-53a)
Mains frequency	50/60 Hz
Load current range	75 mA ... 600 mA (see to derating)
Trigger characteristic in acc. with IEC 60947-4-2	Class 10A
Cooling time	20 min (for auto reset)
Leakage current	0 mA
Residual voltage	< 0.2 V
Protective circuit	Surge protection

Acknowledge output

Note	Confirmation 01: floating changeover contact
------	--

Connection data

Control circuits

Connection method	Screw connection
Stripping length	8 mm
Screw thread	M3
Conductor cross-section rigid	0.2 mm ² ... 2.5 mm ²
Conductor cross-section flexible	0.2 mm ² ... 2.5 mm ²
Conductor cross-section AWG	24 ... 14

Load circuit

Connection method	Screw connection
Stripping length	8 mm
Screw thread	M3
Conductor cross-section rigid	0.2 mm ² ... 2.5 mm ²
Conductor cross-section flexible	0.2 mm ² ... 2.5 mm ²
Conductor cross-section AWG	24 ... 14

Signaling

Status display	LED (yellow)
Operating voltage display	Green LED
Error indication	Red LED

Dimensions

Width	22.5 mm
Height	107 mm
Depth	114 mm

Material specifications

Flammability rating according to UL 94 (Housing)	V0 (Housing)
--	--------------

Environmental and real-life conditions

ELR H3-ES-SC-230AC/500AC-0,6 - Hybrid motor starter



2900686

<https://www.phoenixcontact.com/us/products/2900686>

Ambient conditions

Degree of protection	IP20
Ambient temperature (operation)	-25 °C ... 70 °C
Ambient temperature (storage/transport)	-40 °C ... 80 °C

Approvals

UL data

SCCR	100 kA (480 V AC (fuse: 30 A class CC/30 A class J (high fault)))
	5 kA (480 V AC (fuse: 20 A RK5 (standard fault)))
FLA	0.6 A (480 V)

Standards and regulations

Standards/regulations

Standards/regulations	DIN EN 50178
	EN 60947

Power station requirements

Standards/regulations	DWR 1300/ZXX01/DD/7080.8d
-----------------------	---------------------------

Air clearances and creepage distances between the power circuits

Standards/regulations	DIN EN 50178
-----------------------	--------------

Mounting

Assembly note	can be aligned with spacing = 20 mm
Mounting position	Vertical (horizontal DIN rail)

ELR H3-ES-SC-230AC/500AC-0,6 - Hybrid motor starter

2900686

<https://www.phoenixcontact.com/us/products/2900686>

Drawings

Circuit diagram

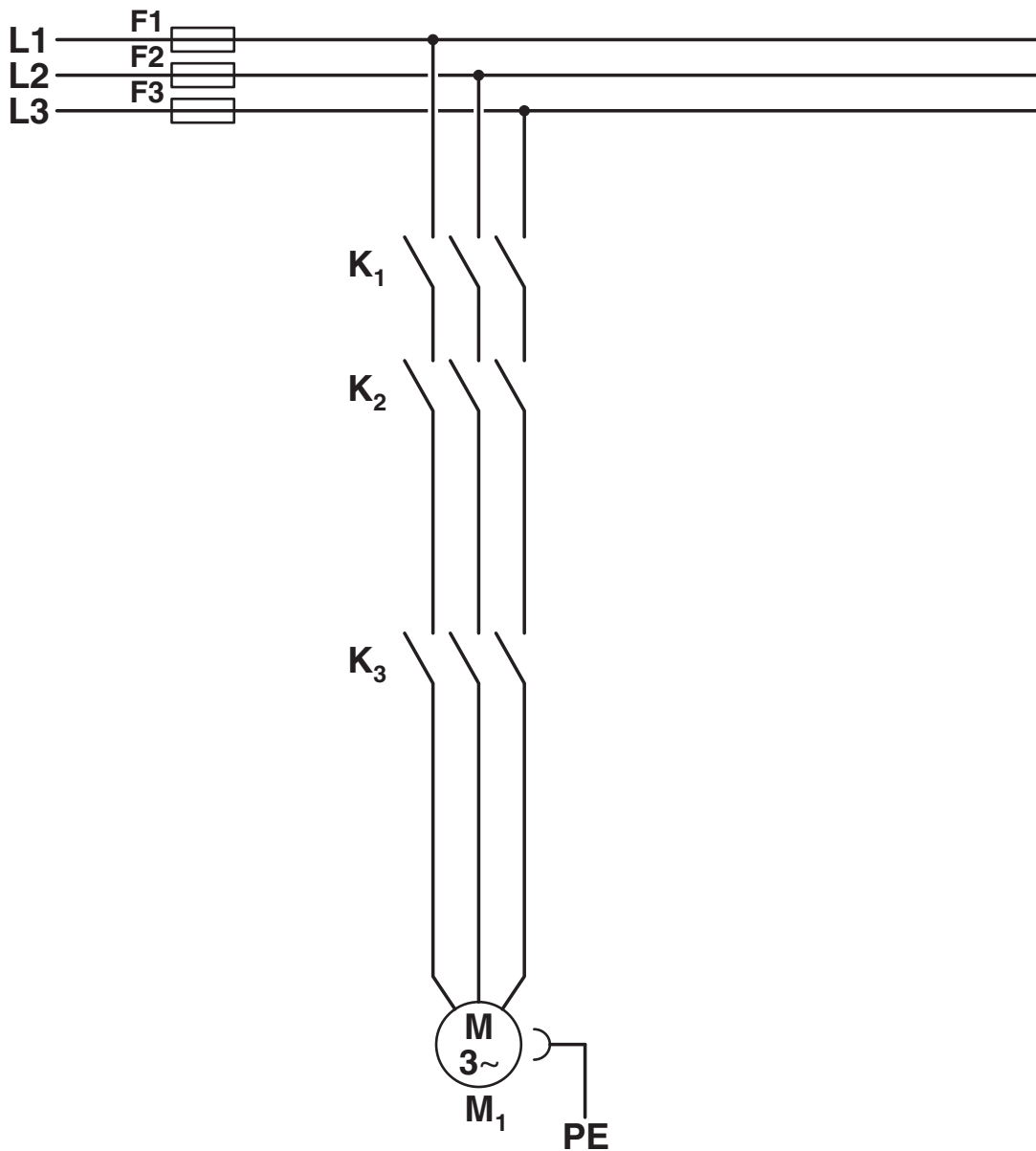

Conventional structure

Main current path for contactor according to category 3

K1 + K2 = Emergency stop contactor

K3 = Right contactor

ELR H3-ES-SC-230AC/500AC-0,6 - Hybrid motor starter

2900686

<https://www.phoenixcontact.com/us/products/2900686>

Circuit diagram

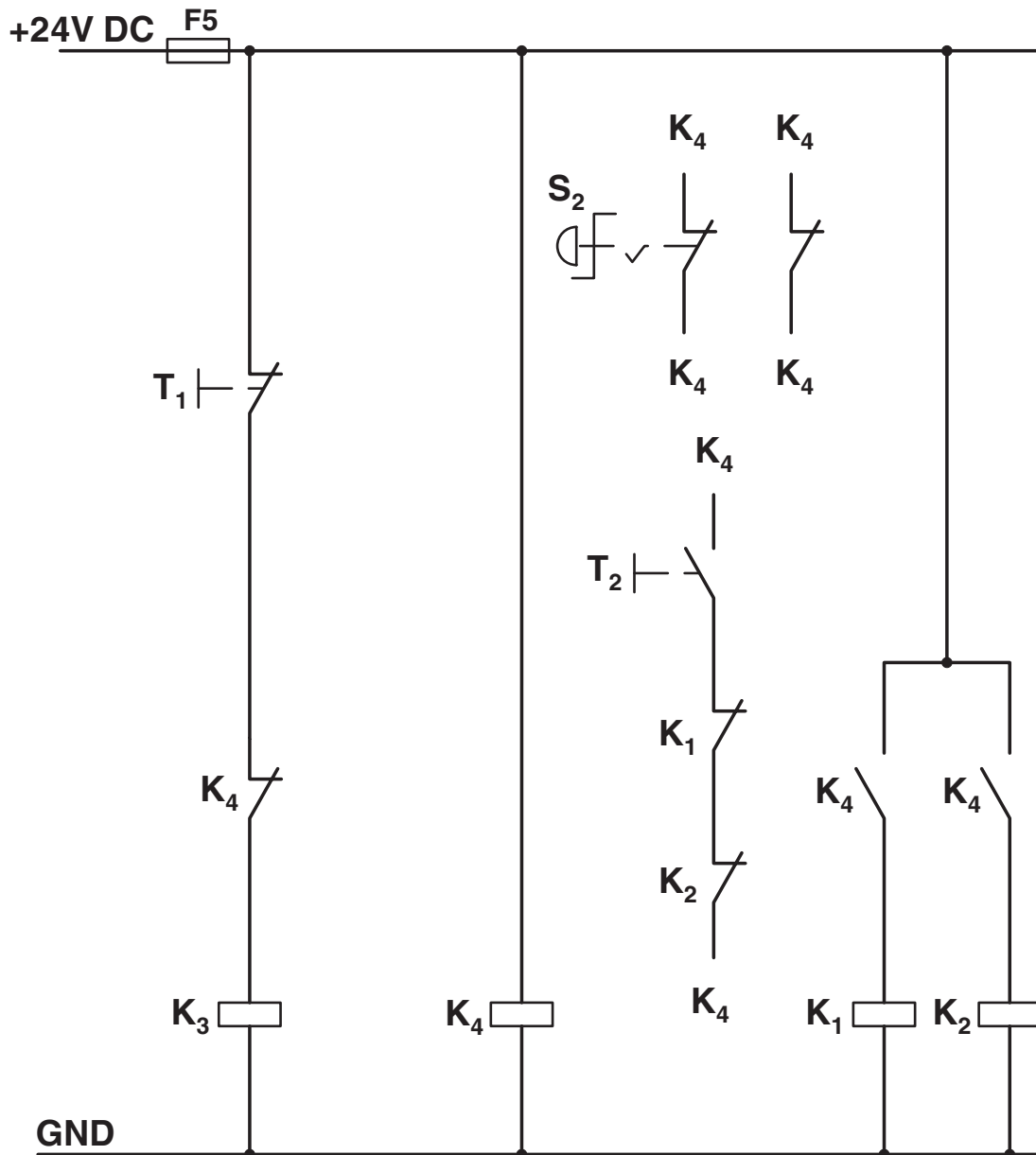

Conventional structure

Control current path for contactor according to category 3

- K1 + K2 = Emergency stop contactor
- K3 = Right contactor
- K4 = PSR SCP-24DC.../safety relay
- T1 = Right, T3 = Reset
- S2 = Emergency stop

ELR H3-ES-SC-230AC/500AC-0,6 - Hybrid motor starter

2900686

<https://www.phoenixcontact.com/us/products/2900686>

Circuit diagram

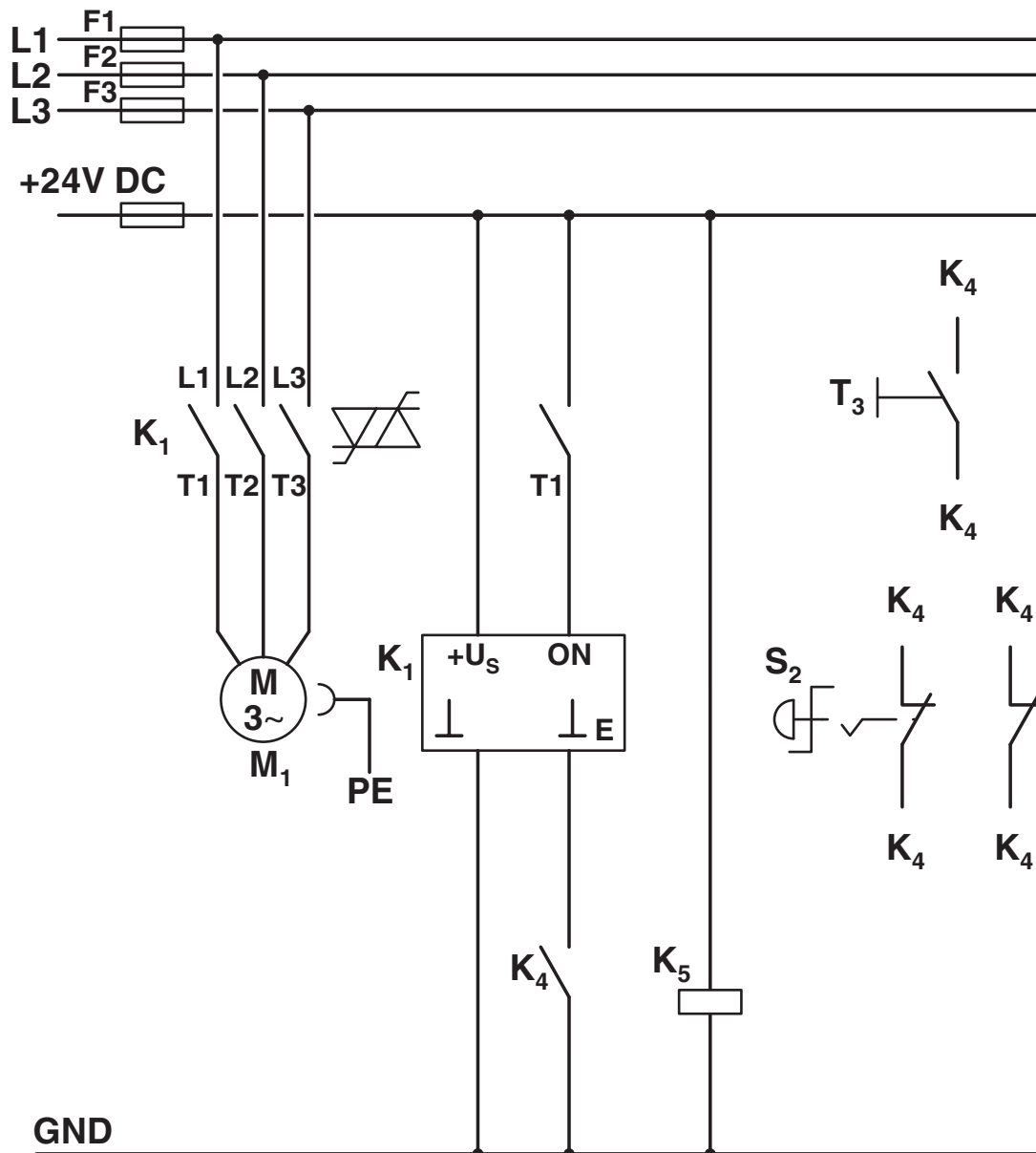

Structure with CONTACTRON

Main and control current path for '2 in 1' hybrid motor starter according to category 3

K1 = '2 in 1' hybrid motor starter

K4 = PSR SCP-24DC.../safety relay

T1 = Right, T3 = Reset

S2 = Emergency stop

ELR H3-ES-SC-230AC/500AC-0,6 - Hybrid motor starter

2900686

<https://www.phoenixcontact.com/us/products/2900686>

Block diagram

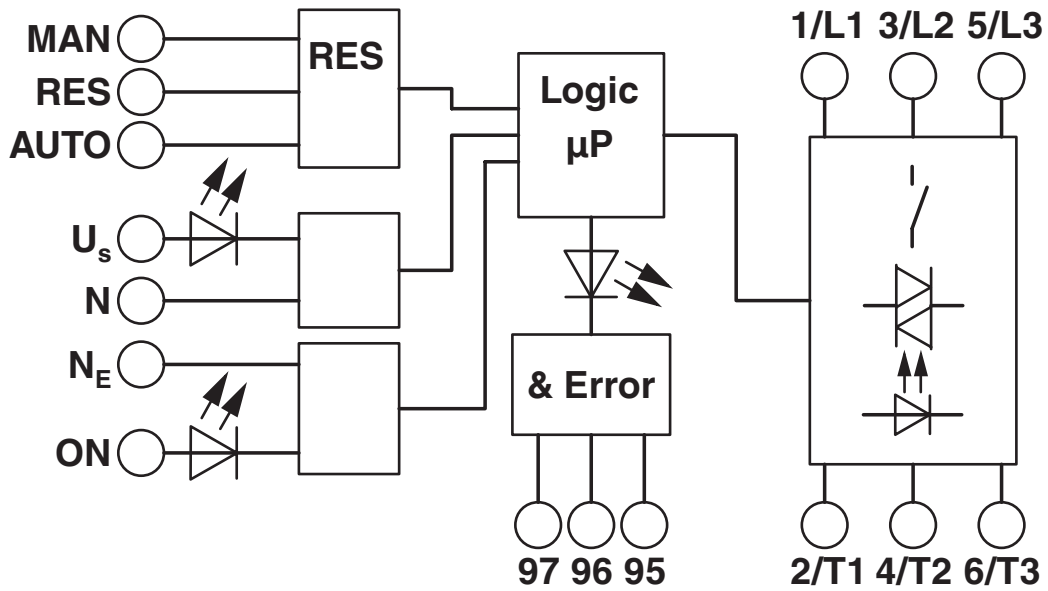

ELR H3-ES-SC-230AC/500AC-0,6 - Hybrid motor starter



2900686

<https://www.phoenixcontact.com/us/products/2900686>

Environmental product compliance

China RoHS

Environment friendly use period (EFUP)	EFUP-50
	An article-related China RoHS declaration table can be found in the download area for the respective article under "Manufacturer declaration". For all articles with EFUP-E, no China RoHS declaration table issued and required.

EU REACH SVHC

REACH candidate substance (CAS No.)	No substance above 0.1 wt%
-------------------------------------	----------------------------

Phoenix Contact 2026 © - all rights reserved
<https://www.phoenixcontact.com>

Phoenix Contact USA
586 Fulling Mill Road
Middletown, PA 17057, United States
(+717) 944-1300
info@phoenixcon.com