

# ELR H3-IES-SC- 24DC/500AC-0,6 - Hybrid motor starter



2900566

<https://www.phoenixcontact.com/us/products/2900566>

Please be informed that the data shown in this PDF document is generated from our online catalog. Please find the complete data in the user documentation. Our general terms of use for downloads are valid.



Hybrid motor starter for starting 3~ AC motors up to 500 V AC and 0.6 A output current, with 24 V DC control voltage, adjustable overload shutdown and emergency stop function to SIL3 /PL e, and screw connection.

## Your advantages

- 22.5 mm wide
- Safety level in accordance with IEC 61508-1: SIL 3, ISO 13849: PL e
- Reduction in wiring
- Long service life
- Space saving
- 3-phase loop bridges
- Adjustable current for bimetal function
- Low-wear switching

## Commercial data

Item number	2900566
Packing unit	1 pc
Minimum order quantity	1 pc
Sales key	C470
Product key	DK7411
GTIN	4046356526128
Weight per piece (including packing)	293.4 g
Weight per piece (excluding packing)	289 g
Customs tariff number	85371098
Country of origin	DE

# ELR H3-IES-SC- 24DC/500AC-0,6 - Hybrid motor starter



2900566

<https://www.phoenixcontact.com/us/products/2900566>

## Technical data

### Product properties

Product type	Hybrid motor starters
Product family	CONTACTRON
Operating mode	100% operating factor

### Electrical properties

Number of phases	3
Motor starter type	Direct starter
Switching frequency	≤ 2 Hz (Load-dependent)
Maximum power dissipation for nominal condition	0.4 W
Switching frequency	≤ 2 Hz (Load-dependent)
Maximum power dissipation	1.5 W
Minimum power dissipation	1.1 W
Coordination type	1

### Supply

Rated control circuit supply voltage $U_S$	24 V DC
Control supply voltage range	19.2 V DC ... 30 V DC
Rated control supply current $I_S$	40 mA
Protective circuit	Surge protection Reverse polarity protection

### Insulation characteristics

Rated insulation voltage	500 V
Rated surge voltage	6 kV
Overvoltage category	III
Degree of pollution	2
Insulation characteristics between the control input and control supply voltage, and auxiliary circuit to the main circuit	Safe isolation (IEC 60947-1) at operating voltage ≤ 300 V AC Basic insulation (IEC 60947-1) at operating voltage 300 V AC ... 500 V AC
Isolation characteristics between the control input and control supply voltage to auxiliary circuit	Safe isolation (IEC 60947-1) in the auxiliary circuit ≤ 300 V AC

## Input data

### Control

Input name	Control input
Rated actuating voltage $U_C$	24 V DC
Triggering voltage range	19.2 V DC ... 30 V DC
Rated actuating current $I_C$	5 mA (Input type 1)
Switching threshold	9.6 V ("0" signal) 19.2 V ("1" signal)
Switching level	< 5 V DC (For EMERGENCY STOP)

# ELR H3-IES-SC- 24DC/500AC-0,6 - Hybrid motor starter



2900566

<https://www.phoenixcontact.com/us/products/2900566>

Typical turn-off time	< 30 ms
Protective circuit	Reverse polarity protection

## Output data

### AC output

Rated operating voltage $U_e$	500 V AC
Operating voltage range	42 V AC ... 550 V AC
Rated operating current $I_e$	0.6 A (AC-51) 0.6 A (AC-53a)
Mains frequency	50/60 Hz
Load current range	75 mA ... 600 mA (see to derating)
Trigger characteristic in acc. with IEC 60947-4-2	Class 10A
Cooling time	20 min (for auto reset)
Leakage current	0 mA
Protective circuit	Surge protection

### Acknowledge output

Note	Confirmation: floating change-over contact, signal contact
Contact switching type	1 changeover contact
Switching capacity in accordance with IEC 60947-5-1	3 A (230 V, AC15) 2 A (24 V (DC13))

## Connection data

### Control circuits

Connection method	Screw connection
Stripping length	8 mm
Screw thread	M3
Conductor cross-section rigid	0.2 mm <sup>2</sup> ... 2.5 mm <sup>2</sup>
Conductor cross-section flexible	0.2 mm <sup>2</sup> ... 2.5 mm <sup>2</sup>
Conductor cross-section AWG	24 ... 14
Tightening torque	0.5 Nm ... 0.6 Nm 5 lb <sub>f</sub> -in. ... 7 lb <sub>f</sub> -in.

### Load circuit

Connection method	Screw connection
Stripping length	8 mm
Screw thread	M3
Conductor cross-section rigid	0.2 mm <sup>2</sup> ... 2.5 mm <sup>2</sup>
Conductor cross-section flexible	0.2 mm <sup>2</sup> ... 2.5 mm <sup>2</sup>
Conductor cross-section AWG	24 ... 14
Tightening torque	0.5 Nm ... 0.6 Nm 5 lb <sub>f</sub> -in. ... 7 lb <sub>f</sub> -in.

## Signaling

# ELR H3-IES-SC- 24DC/500AC-0,6 - Hybrid motor starter



2900566

<https://www.phoenixcontact.com/us/products/2900566>

Status display	LED (yellow)
Operating voltage display	Green LED
Error indication	Red LED

## Dimensions

Width	22.5 mm
Height	107 mm
Depth	114 mm

## Material specifications

Flammability rating according to UL 94 (Housing)	V0 (Housing)
--	--------------

## Environmental and real-life conditions

### Ambient conditions

Degree of protection	IP20
Ambient temperature (operation)	-25 °C ... 70 °C (observe derating)
Ambient temperature (storage/transport)	-40 °C ... 80 °C
Altitude	≤ 2000 m

## Approvals

### ATEX

Identification	⊕ II (2) G [Ex e] [Ex d] [Ex px]
	⊕ II (2) D [Ex t] [Ex p]
Certificate	PTB 07 ATEX 3145

### UL approval

Certificate	NLDX.E228652
-------------	--------------

### Safety Integrity Level (SIL, IEC 61508)

Identification	≤ 3
Note	Safe shutdown

### Safety Integrity Level (SIL, IEC 61508)

Identification	2
Note	Motor protection

### Performance Level (ISO 13849)

Identification	≤ e
Note	Safe shutdown

### Category (ISO 13849)

Identification	≤ 3
Note	Safe shutdown

### UL data

SCCR	100 kA (500 V AC (fuse: 30 A class CC/30 A class J (high fault)))
------	---

# ELR H3-IES-SC- 24DC/500AC-0,6 - Hybrid motor starter



2900566

<https://www.phoenixcontact.com/us/products/2900566>

	5 kA (500 V AC (fuse: 20 A RK5 (standard fault)))
FLA	0.6 A (500 V AC)
Group installation	20 A (class RK5, SCCR 5kA, #24 - 14 AWG max. solid and stranded)
	30 A (class CC or J, SCCR 100kA, #24 - 14 AWG max, solid and stranded)
Category code	NLDX

## Standards and regulations

### Standards/regulations

Standards/regulations	IEC 60947-1
	IEC 60947-4-2
	IEC 61508
	ISO 13849

## Mounting

Mounting type	DIN rail mounting
Assembly note	alignable, for spacing see derating
Mounting position	vertical (horizontal DIN rail, motor output below)

2900566

<https://www.phoenixcontact.com/us/products/2900566>

Drawings

Diagram



Derating diagram

# ELR H3-IES-SC- 24DC/500AC-0,6 - Hybrid motor starter

2900566

<https://www.phoenixcontact.com/us/products/2900566>

Circuit diagram



## Conventional structure

Main current path for contactor according to category 3

K1 + K2 = Emergency stop contactor

K3 = Right contactor

F4 = Motor protection relay

2900566

<https://www.phoenixcontact.com/us/products/2900566>

Circuit diagram

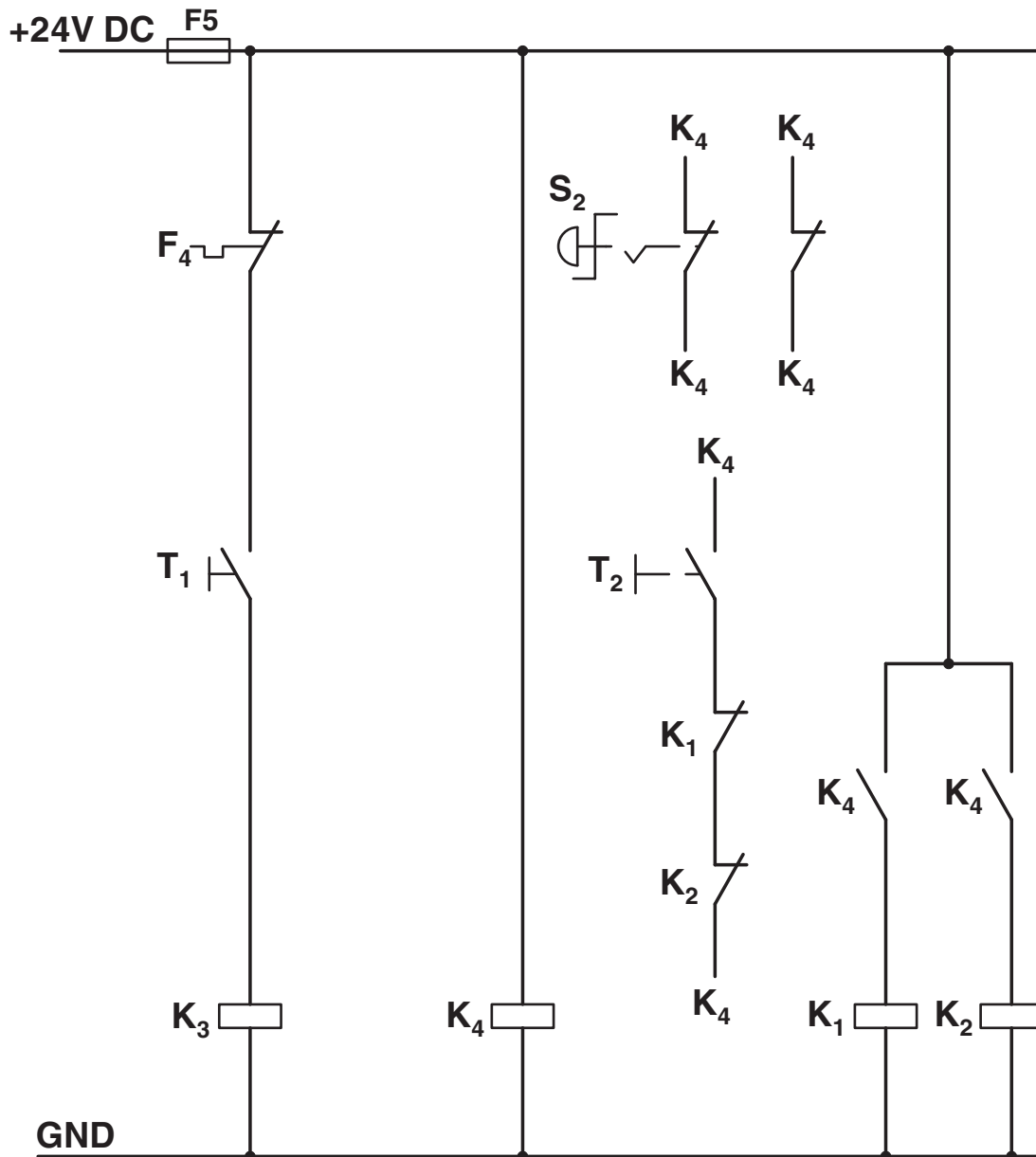

### Conventional structure

Control current path for contactor according to category 3

K1 + K2 = Emergency stop contactor

K3 = Right contactor

K4 = PSR SCP-24DC.../safety relay

T1 = Right, T3 = Reset

S2 = Emergency stop

F4 = Motor protection relay

# ELR H3-IES-SC- 24DC/500AC-0,6 - Hybrid motor starter

2900566

<https://www.phoenixcontact.com/us/products/2900566>

Circuit diagram



## Structure with CONTACTRON

Main and control current path for '3 in 1' hybrid motor starter according to category 3

K1 = '3 in 1' hybrid motor starter

K4 = PSR SCP-24DC.../safety relay

T1 = Right, T3 = Reset

S2 = Emergency stop

# ELR H3-IES-SC- 24DC/500AC-0,6 - Hybrid motor starter



2900566

<https://www.phoenixcontact.com/us/products/2900566>



# ELR H3-IES-SC- 24DC/500AC-0,6 - Hybrid motor starter



2900566

<https://www.phoenixcontact.com/us/products/2900566>

## Approvals

To download certificates, visit the product detail page: <https://www.phoenixcontact.com/us/products/2900566>



**IECEE CB Scheme**  
Approval ID: DE1-55728



**EAC**  
Approval ID: RU\*C-DE.\*08.B.00520\*



**UL Listed**  
Approval ID: FILE E 323771



**CCC**  
Approval ID: 2016010304871315



**cUL Listed**  
Approval ID: FILE E 323771



**cUL Listed**  
Approval ID: E228652



**UL Listed**  
Approval ID: E228652



**CCC**  
Approval ID: 2024010304672817



**ATEX**  
Approval ID: PTB 07 ATEX 3145

# ELR H3-IES-SC- 24DC/500AC-0,6 - Hybrid motor starter



2900566

<https://www.phoenixcontact.com/us/products/2900566>

## Classifications

### ECLASS

ECLASS-13.0	27370905
ECLASS-15.0	27370905
ECLASS-15.0 ASSET	27250101

### ETIM

ETIM 10.0	EC001037
-----------	----------

### UNSPSC

UNSPSC 21.0	25173900
-------------	----------

# ELR H3-IES-SC- 24DC/500AC-0,6 - Hybrid motor starter



2900566

<https://www.phoenixcontact.com/us/products/2900566>

## Environmental product compliance

### EU RoHS

Fulfills EU RoHS substance requirements	Yes
Exemption	7(a), 7(c)-I

### China RoHS

Environment friendly use period (EFUP)	EFUP-50
	An article-related China RoHS declaration table can be found in the download area for the respective article under "Manufacturer declaration". For all articles with EFUP-E, no China RoHS declaration table issued and required.

### EU REACH SVHC

REACH candidate substance (CAS No.)	1-Methyl-2-pyrrolidone (NMP)(CAS: 872-50-4)
	Lead(CAS: 7439-92-1)
	2,2',6,6'-tetrabromo-4,4'-isopropylidenediphenol(CAS: 79-94-7)
SCIP	7efcee12-9b75-46bf-aaa7-a2f4d5612b0e

Phoenix Contact 2026 © - all rights reserved  
<https://www.phoenixcontact.com>

Phoenix Contact USA  
586 Fulling Mill Road  
Middletown, PA 17057, United States  
(+717) 944-1300  
[info@phoenixcon.com](mailto:info@phoenixcon.com)