

# ELR H3-ES-SC- 24DC/500AC-9 - Hybrid motor starter



2900554

<https://www.phoenixcontact.com/us/products/2900554>

Please be informed that the data shown in this PDF document is generated from our online catalog. Please find the complete data in the user documentation. Our general terms of use for downloads are valid.



Hybrid motor starter for starting 3~ AC motors up to 550 V AC, with 24 V DC input, 9 A output current, and emergency stop function.

## Your advantages

- 22.5 mm wide
- Low-wear switching
- Safety level in accordance with IEC 61508-1: SIL 3, ISO 13849: PL e
- Reduction in wiring up to 9 A
- Space saving
- Long service life
- 3-phase loop bridges

## Commercial data

Item number	2900554
Packing unit	1 pc
Note	Made to order (non-returnable)
Sales key	NULL
Product key	DK7413
GTIN	4046356527767
Weight per piece (including packing)	287.1 g
Weight per piece (excluding packing)	204.54 g
Customs tariff number	85371099
Country of origin	DE

## Technical data

### Product properties

Product type	Hybrid motor starters
Product family	CONTACTRON
Operating mode	100% operating factor

Insulation characteristics: Air clearances and creepage distances between the power circuits

Insulation	safe isolation
Overvoltage category	III
Degree of pollution	2

### Electrical properties

Number of phases	3
Service life electrical	$3 \times 10^7$ cycles
Reversing frequency	$\leq 2$ Hz
Maximum power dissipation	14.6 W
Minimum power dissipation	1.1 W
Coordination type	1

Air clearances and creepage distances between the power circuits

Rated insulation voltage	500 V
Rated surge voltage	6 kV

### Supply

Rated control circuit supply voltage $U_S$	24 V DC
Control supply voltage range	19.2 V DC ... 30 V DC
Rated control supply current $I_S$	40 mA
Protective circuit	Surge protection
	Reverse polarity protection; Parallel polarity protection diode

### Emergency tripping

Operate threshold	$> 45$ A
Response time	$< 2$ s

## Input data

### Control

Rated actuating voltage $U_C$	24 V DC
Triggering voltage range	19.2 V DC ... 30 V DC
Switching threshold	9.6 V ("0" signal)
	19.2 V ("1" signal)
Switching level	$< 5$ V DC (For EMERGENCY STOP)
Typical turn-off time	$< 30$ ms

## Output data

# ELR H3-ES-SC- 24DC/500AC-9 - Hybrid motor starter



2900554

<https://www.phoenixcontact.com/us/products/2900554>

## AC output

Rated operating voltage $U_e$	500 V AC
Operating voltage range	42 V AC ... 550 V AC
Rated operating current $I_e$	9 A (AC-51)
	6.5 A (AC-53a)
Mains frequency	50/60 Hz
Load current range	1.5 A ... 9 A (see to derating)
Trigger characteristic in acc. with IEC 60947-4-2	Class 10A
Cooling time	20 min (for auto reset)
Leakage current	0 mA
Residual voltage	< 0.5 V
Protective circuit	Surge protection

## Acknowledge output

Note	Confirmation 01: floating changeover contact
------	----------------------------------------------

## Connection data

### Control circuits

Connection method	Screw connection
Stripping length	8 mm
Screw thread	M3
Conductor cross-section rigid	0.2 mm <sup>2</sup> ... 2.5 mm <sup>2</sup>
Conductor cross-section flexible	0.2 mm <sup>2</sup> ... 2.5 mm <sup>2</sup>
Conductor cross-section AWG	24 ... 14

### Load circuit

Connection method	Screw connection
Stripping length	8 mm
Screw thread	M3
Conductor cross-section rigid	0.2 mm <sup>2</sup> ... 2.5 mm <sup>2</sup>
Conductor cross-section flexible	0.2 mm <sup>2</sup> ... 2.5 mm <sup>2</sup>
Conductor cross-section AWG	24 ... 14

## Signaling

Status display	LED (yellow)
Operating voltage display	Green LED
Error indication	Red LED

## Dimensions

Width	22.5 mm
Height	107 mm
Depth	114 mm

## Material specifications

# ELR H3-ES-SC- 24DC/500AC-9 - Hybrid motor starter



2900554

<https://www.phoenixcontact.com/us/products/2900554>

Flammability rating according to UL 94 (Housing)	V0 (Housing)
--------------------------------------------------	--------------

## Environmental and real-life conditions

### Ambient conditions

Degree of protection	IP20
Ambient temperature (operation)	-25 °C ... 70 °C
Ambient temperature (storage/transport)	-40 °C ... 80 °C

## Approvals

### Safety Integrity Level (SIL, IEC 61508)

Identification	≤ 3
Note	Safe shutdown

### Performance Level (ISO 13849)

Identification	e
Note	Safe shutdown

### Category (ISO 13849)

Identification	≤ 3
Note	Safe shutdown

### UL data

SCCR	100 kA (480 V AC (fuse: 30 A class CC/30 A class J (high fault)))
	5 kA (480 V AC (fuse: 20 A RK5 (standard fault)))
FLA	6.5 A (480 V)

## Standards and regulations

### Standards/regulations

Standards/regulations	DIN EN 50178
	EN 60947

### Power station requirements

Standards/regulations	DWR 1300/ZXX01/DD/7080.8d
-----------------------	---------------------------

### Air clearances and creepage distances between the power circuits

Standards/regulations	DIN EN 50178
-----------------------	--------------

## Mounting

Assembly note	can be aligned with spacing = 20 mm
Mounting position	Vertical (horizontal DIN rail)

## Drawings

Circuit diagram

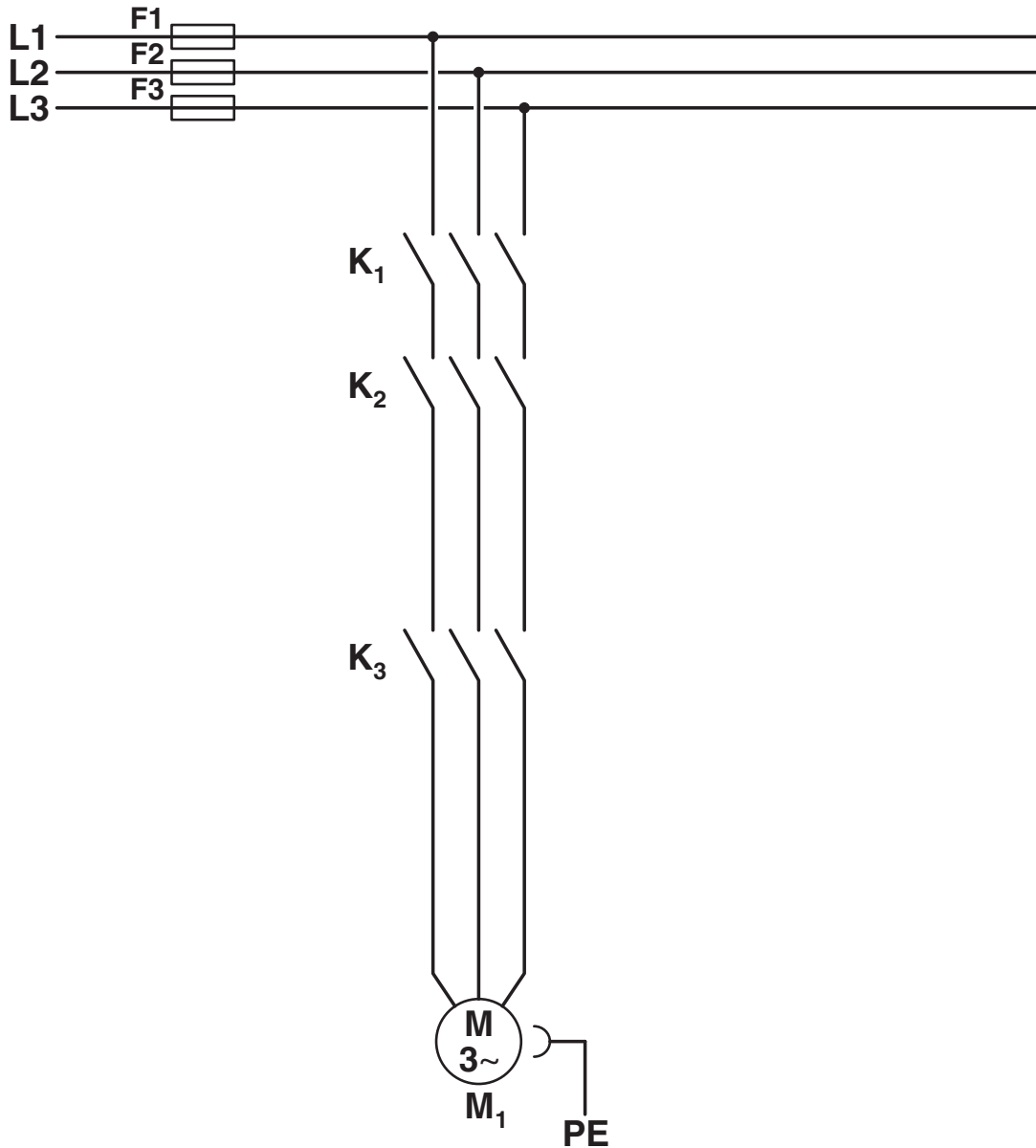

### Conventional structure

Main current path for contactor according to category 3

K1 + K2 = Emergency stop contactor

K3 = Right contactor

Circuit diagram

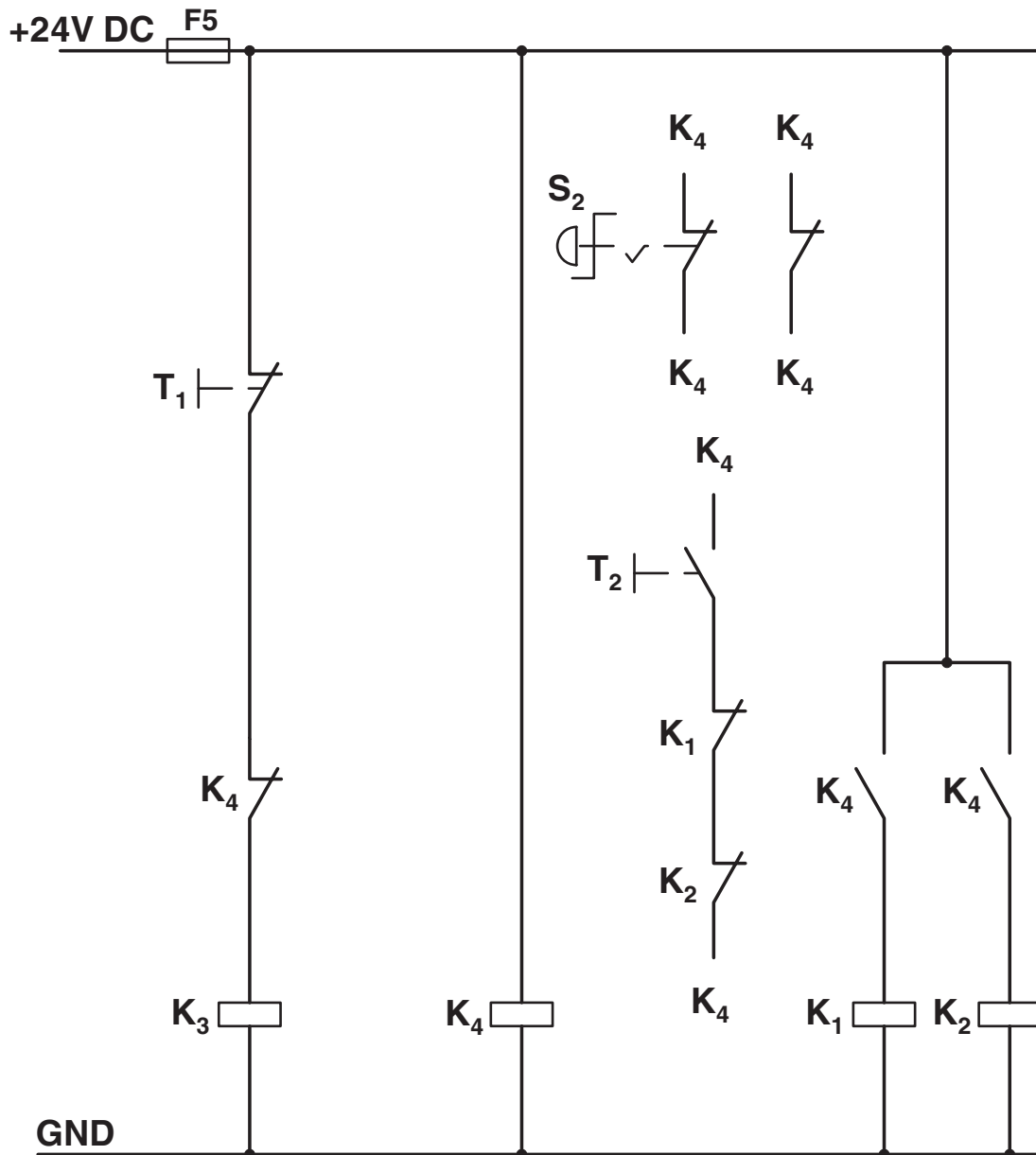

### Conventional structure

Control current path for contactor according to category 3

K1 + K2 = Emergency stop contactor

K3 = Right contactor

K4 = PSR SCP-24DC.../safety relay

T1 = Right, T3 = Reset

S2 = Emergency stop

Circuit diagram

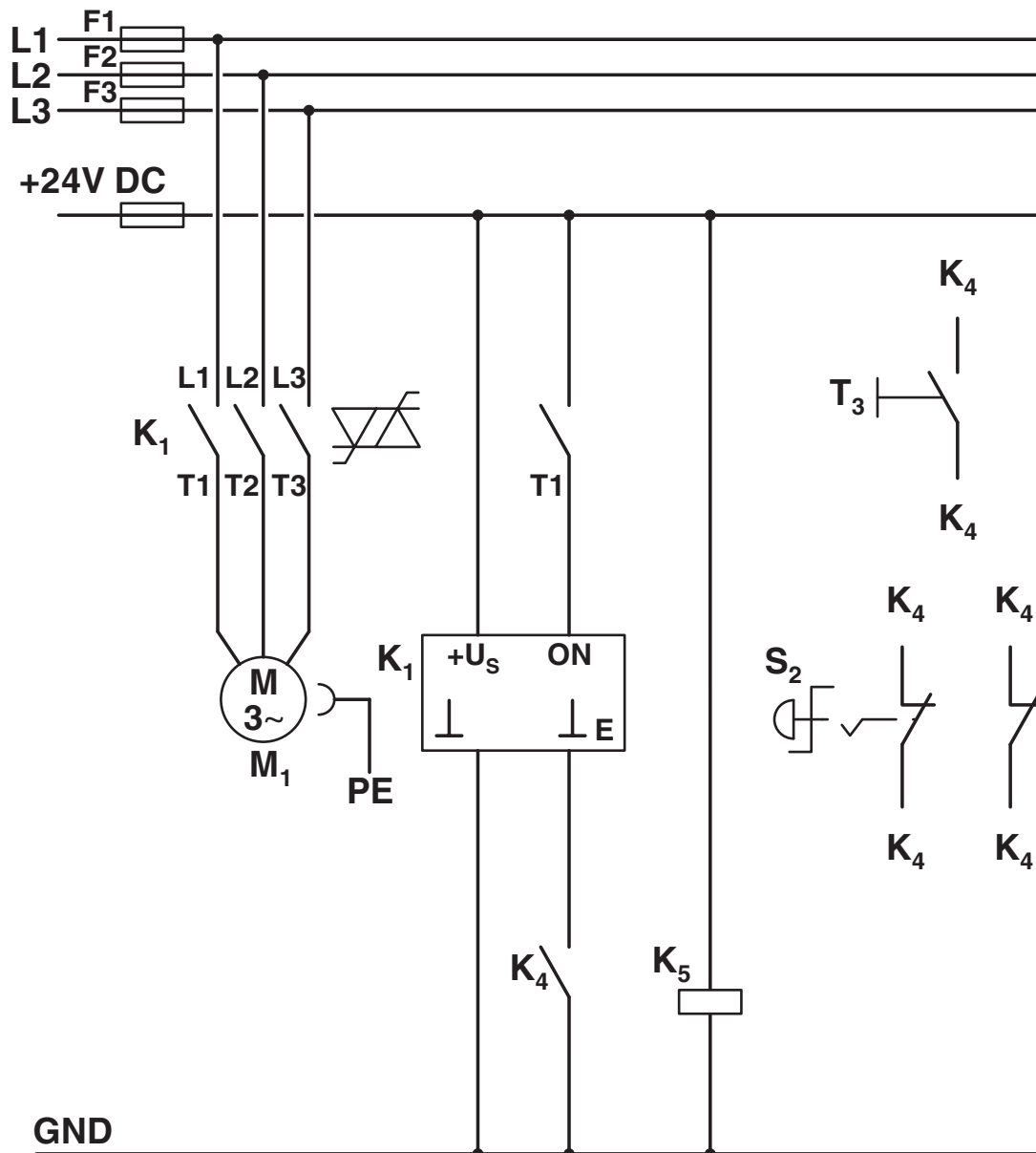

### Structure with CONTACTRON

Main and control current path for '2 in 1' hybrid motor starter according to category 3

K1 = '2 in 1' hybrid motor starter

K4 = PSR SCP-24DC.../safety relay

T1 = Right, T3 = Reset

S2 = Emergency stop

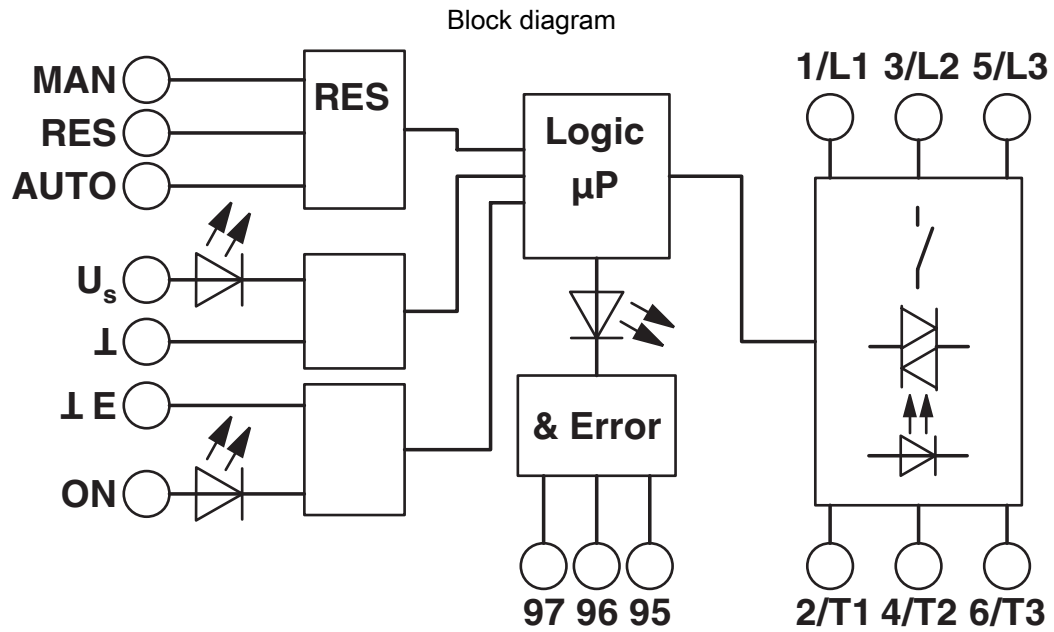

2900554

<https://www.phoenixcontact.com/us/products/2900554>

## Environmental product compliance

### China RoHS

Environment friendly use period (EFUP)	EFUP-50
	An article-related China RoHS declaration table can be found in the download area for the respective article under "Manufacturer declaration". For all articles with EFUP-E, no China RoHS declaration table issued and required.

### EU REACH SVHC

REACH candidate substance (CAS No.)	No substance above 0.1 wt%
-------------------------------------	----------------------------

Phoenix Contact 2026 © - all rights reserved  
<https://www.phoenixcontact.com>

Phoenix Contact USA  
586 Fulling Mill Road  
Middletown, PA 17057, United States  
(+717) 944-1300  
[info@phoenixcon.com](mailto:info@phoenixcon.com)