

FL SWITCH SFNT 5GT - Industrial Ethernet Switch



2891390

<https://www.phoenixcontact.com/us/products/2891390>

Please be informed that the data shown in this PDF document is generated from our online catalog. Please find the complete data in the user documentation. Our general terms of use for downloads are valid.



Wide-temperature Ethernet switch, five TP RJ45 ports, automatic detection of data transmission speed of 10/100/1000 Mbps (RJ45), autocrossing function, reads QoS priority messages, accepts security frames.

Product description

The FL SWITCH SFN 5GT supports the auto negotiation function at the twisted-pair ports and offers transmission speeds of 10/100/1000 Mbps. Mixed operation for the connection of segments with different data transmission speeds is also supported.

Switching properties

-Multi-address function

The switch can store up to 8192 MAC addresses in its address table.

-Quality of service

In case of heavy traffic, packets tagged with higher priority 802.1Q or Differentiated Services values will be given preference. The switch has four internal priority queues.

-Multicast filtering

The multicast filter will block PROFINET PTCP-Delay traffic. This is accomplished by filtering frames with the destination MAC address in the range 01-80-C2-00-00-02 through 01-80-C2-00-00-0F. Note that the filter blocks LLDP traffic because PTCP-Delay uses the same MAC address, 01-80-C2-00-00-0E.

-Alarm contact

The switch provides contacts (R1, R2) for remote alarms if a failure is detected. Alarms are triggered if one or both power supplies fail. An alarm can be triggered if a port link is lost. Individual port alarms can be enabled via a DIP switch located on the bottom of the switch. The alarm relay is a normally closed type. When there are no faults, the contact is held open. When a fault occurs, the relay is de-energized to close the contact.

-Link monitor DIP switch

To enable an alarm for a port, move the appropriate slider to the ON position. To disable an alarm, move the appropriate slider to the OFF position.

Power connection is via a removable COMBICON connector. US1 and US2 are 24 V DC and GND is 0 V DC. FE symbol is functional earth.

Your advantages

- All ports offer transmission speeds of 1000 Mbps
- Wide operating temperature range of -40 °C ... 75 °C
- Jumbo frame support (frame size up to 10,240 bytes/frame)
- QoS-prioritized (Quality of Service) messages
- Alarm contact for power supply and link status diagnostics
- The switch also offers cable locking and port blocking

Commercial data

FL SWITCH SFNT 5GT - Industrial Ethernet Switch



2891390

<https://www.phoenixcontact.com/us/products/2891390>

Item number	2891390
Packing unit	1 pc
Minimum order quantity	1 pc
Sales key	DN19
Product key	DNN113
GTIN	4055626000893
Weight per piece (including packing)	520 g
Weight per piece (excluding packing)	380 g
Customs tariff number	85176200
Country of origin	TW

FL SWITCH SFNT 5GT - Industrial Ethernet Switch



2891390

<https://www.phoenixcontact.com/us/products/2891390>

Technical data

Dimensions

Width	30 mm
Height	130 mm
Depth	100 mm

Notes

Note on application

Note on application	Only for industrial use
---------------------	-------------------------

Utilization restriction

CCCex note	Use in potentially explosive areas is not permitted in China.
------------	---

Material specifications

Housing material	Aluminum
------------------	----------

Mounting

Mounting type	DIN rail mounting
---------------	-------------------

Interfaces

Ethernet (RJ45)

Connection method	RJ45
Note on the connection method	Auto negotiation and autocrossing
Transmission speed	10/100/1000 Mbps
Transmission physics	Ethernet in RJ45 twisted pair
No. of channels	5 (RJ45 ports)

Product properties

Product type	Switch
Product family	Unmanaged Switch SFNT
Type	Block design
MTTF	121.4 Years (MIL-HDBK-217F standard, temperature 25°C, operating cycle 100%)

Switch functions

Basic functions	Unmanaged switch / autonegotiation, complies with IEEE 802.3, store and forward switching mode, includes QoS and alarm contact
PROFINET conformance class	Conformance Class A
Status and diagnostic indicators	LEDs: U _{S1} , U _{S2} (redundant voltage supply), link and activity per port
Additional functions	Autonegotiation
	Jumbo frames (max. 10240 bytes)

FL SWITCH SFNT 5GT - Industrial Ethernet Switch



2891390

<https://www.phoenixcontact.com/us/products/2891390>

Security functions

Basic functions	Unmanaged switch / autonegotiation, complies with IEEE 802.3, store and forward switching mode, includes QoS and alarm contact
-----------------	--

Electrical properties

Maximum power dissipation for nominal condition	5.35 W
Transmission medium	Copper

Supply

Supply voltage (DC)	24 V DC (redundant)
Supply voltage range	10 V DC ... 60 V DC
Power supply connection	Via COMBICON, max. conductor cross-section 2.5 mm ²
Inrush current	7.2 A (400 µs)
Residual ripple	3.6 V _{PP} (within the permitted voltage range)
Max. current consumption	547 mA (10 V DC)
Typical current consumption	223 mA (at U _S = 24 V DC)

Connection data

Connection method	Screw connection
Conductor cross-section, rigid	0.2 mm ² ... 2.5 mm ²
Conductor cross-section, flexible	0.2 mm ² ... 2.5 mm ²
Conductor cross-section AWG	24 ... 12
Stripping length	7 mm

Environmental and real-life conditions

Ambient conditions

Degree of protection	IP20
Ambient temperature (operation)	-40 °C ... 75 °C
Ambient temperature (storage/transport)	-40 °C ... 85 °C
Permissible humidity (operation)	5 % ... 95 % (non-condensing)
Air pressure (operation)	62 kPa ... 108 kPa (up to 4850 m above mean sea level)
Air pressure (storage/transport)	62 kPa ... 108 kPa (up to 4850 m above mean sea level)

Approvals

Conformity/Approvals

UL, USA / Canada	Class I, Div. 2, Groups A, B, C, D
------------------	------------------------------------

EMC data

Electromagnetic compatibility	Conformance with EMC Directive 2004/108/EC
Noise immunity	EN 61000-6-2:2005

Noise emission

Standards/regulations	EN 61000-6-4
-----------------------	--------------

FL SWITCH SFNT 5GT - Industrial Ethernet Switch



2891390

<https://www.phoenixcontact.com/us/products/2891390>

System properties

Functionality

Basic functions

Unmanaged switch / autonegotiation, complies with IEEE 802.3, store and forward switching mode, includes QoS and alarm contact

Signaling

Status display

LEDs: U_{S1} , U_{S2} (redundant voltage supply), link and activity per port

FL SWITCH SFNT 5GT - Industrial Ethernet Switch



2891390

<https://www.phoenixcontact.com/us/products/2891390>

Drawings

Connection diagram

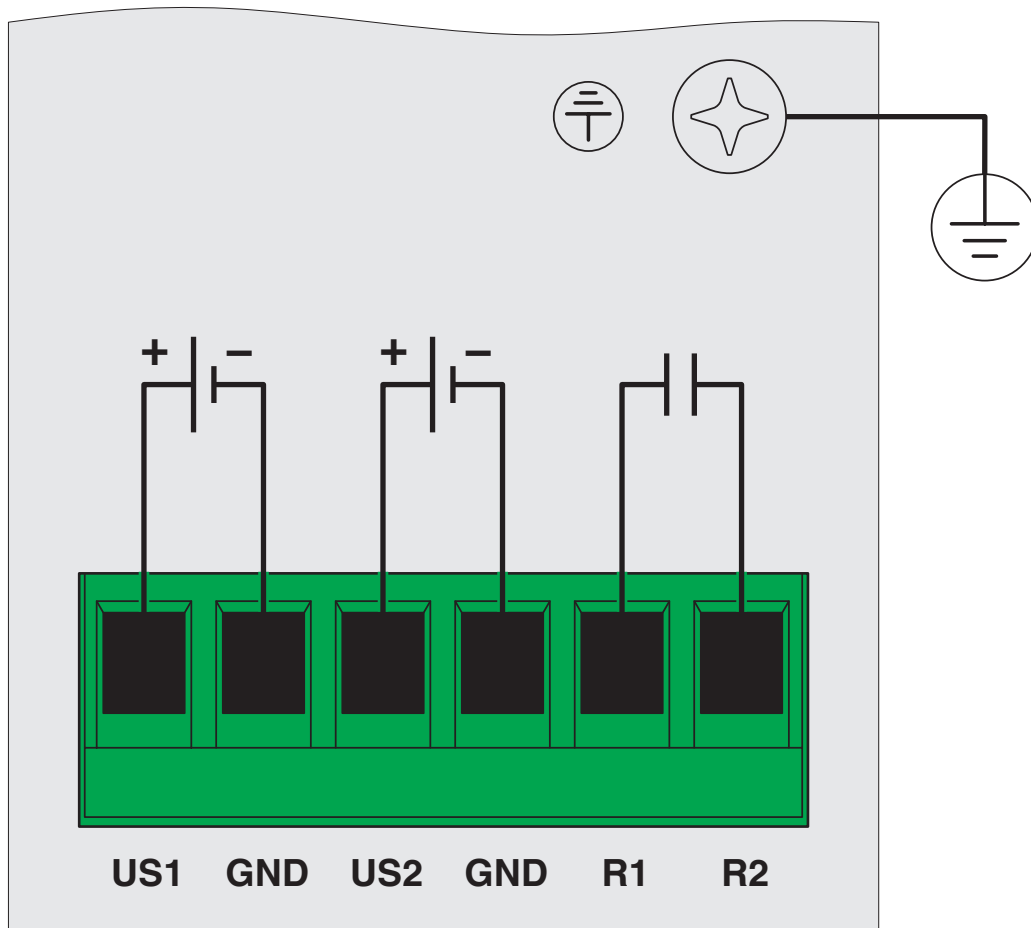

Redundant power supply connection

FL SWITCH SFNT 5GT - Industrial Ethernet Switch



2891390

<https://www.phoenixcontact.com/us/products/2891390>

Connection diagram

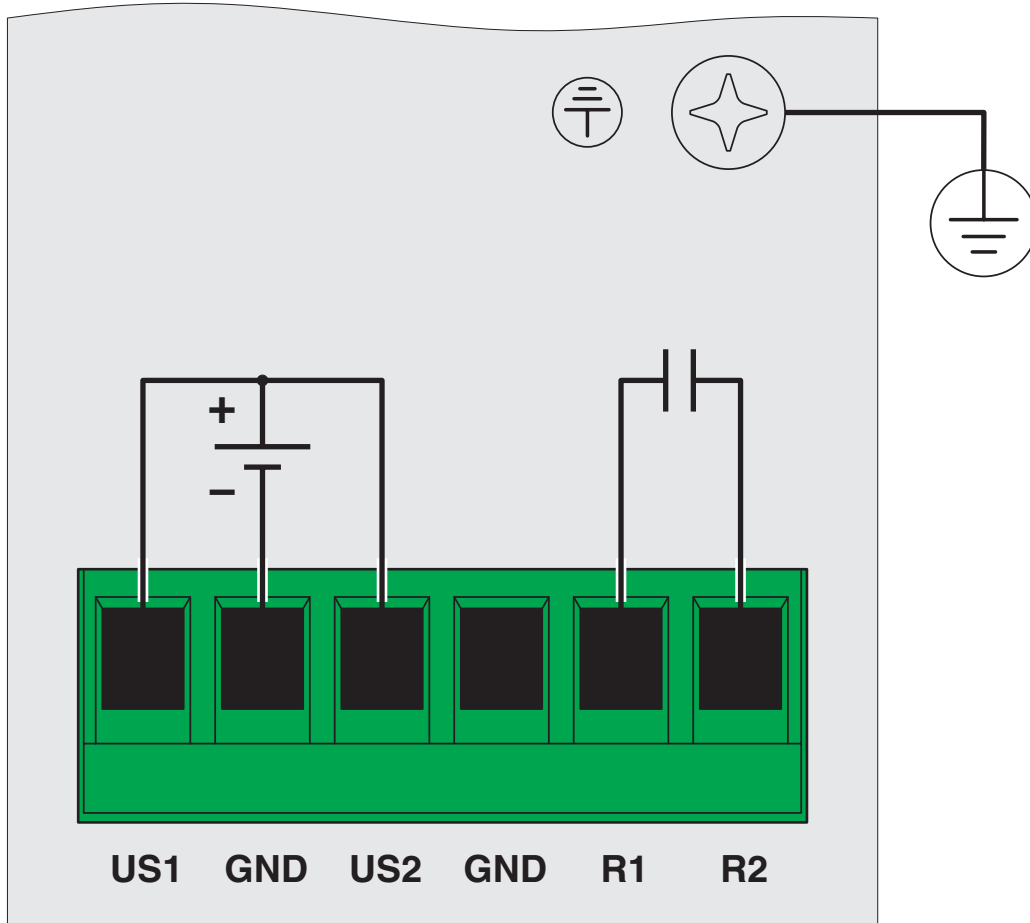

Single power supply connection

FL SWITCH SFNT 5GT - Industrial Ethernet Switch



2891390

<https://www.phoenixcontact.com/us/products/2891390>

Classifications

ECLASS

ECLASS-13.0

19170402

ETIM

ETIM 9.0

EC000734

UNSPSC

UNSPSC 21.0

43222600

2891390

<https://www.phoenixcontact.com/us/products/2891390>

Environmental product compliance

EU RoHS

Fulfills EU RoHS substance requirements	Yes
Exemption	6(c), 7(a), 7(c)-I

China RoHS

Environment friendly use period (EFUP)	EFUP-10
	An article-related China RoHS declaration table can be found in the download area for the respective article under "Manufacturer declaration". For all articles with EFUP-E, no China RoHS declaration table issued and required.

EU REACH SVHC

REACH candidate substance (CAS No.)	Lead(CAS: 7439-92-1)
SCIP	b88a4616-3010-4ce1-be40-2e098fcbd532

Phoenix Contact 2026 © - all rights reserved

<https://www.phoenixcontact.com>

Phoenix Contact USA
586 Fulling Mill Road
Middletown, PA 17057, United States
(+717) 944-1300
info@phoenixcon.com