

FL PA SFNT 5-8 - Mounting panel

2891012

<https://www.phoenixcontact.com/us/products/2891012>

Please be informed that the data shown in this PDF document is generated from our online catalog. Please find the complete data in the user documentation. Our general terms of use for downloads are valid.

Mounting plate for SFNT switches



Product description

Mounting plate for 5- and 8-port SFNT switches

Commercial data

Item number	2891012
Packing unit	1 pc
Minimum order quantity	1 pc
Sales key	DN22
Product key	DNN1ZZ
GTIN	4046356587075
Weight per piece (including packing)	238 g
Weight per piece (excluding packing)	224 g
Customs tariff number	76169990
Country of origin	TW

FL PA SFNT 5-8 - Mounting panel



2891012

<https://www.phoenixcontact.com/us/products/2891012>

Technical data

Notes

Note on application

Note on application	Only for industrial use
---------------------	-------------------------

Product properties

Product type	Assembly adapter
--------------	------------------

Dimensions

Dimensional drawing	
Width	140 mm
Height	130 mm

FL PA SFNT 5-8 - Mounting panel

2891012

<https://www.phoenixcontact.com/us/products/2891012>



Drawings

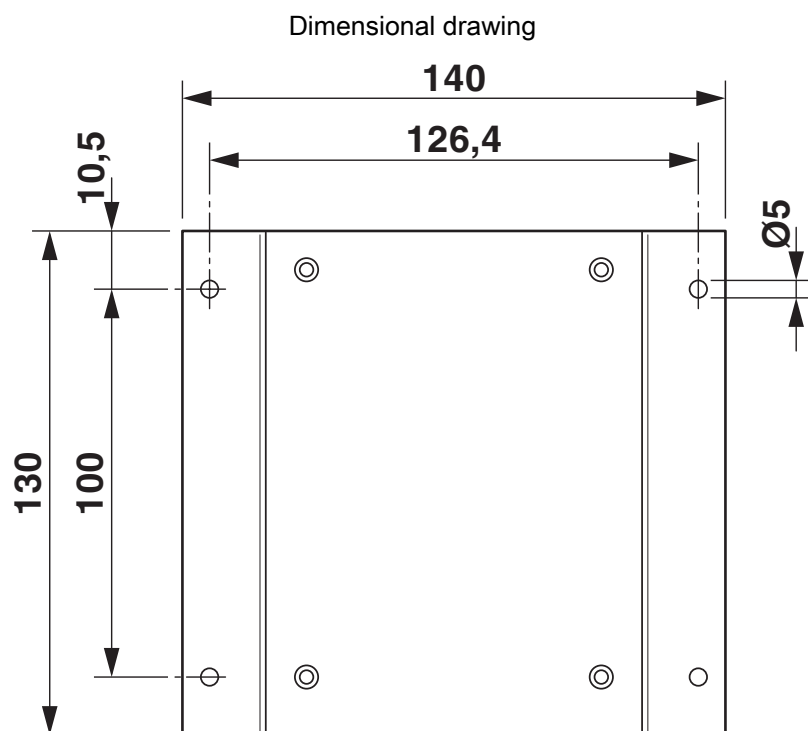

FL PA SFNT 5-8 - Mounting panel



2891012

<https://www.phoenixcontact.com/us/products/2891012>

Classifications

ECLASS

ECLASS-13.0

27371392

ETIM

ETIM 9.0

EC002498

UNSPSC

UNSPSC 21.0

39121100

FL PA SFNT 5-8 - Mounting panel



2891012

<https://www.phoenixcontact.com/us/products/2891012>

Environmental product compliance

EU RoHS

Fulfills EU RoHS substance requirements	Yes, No exemptions
---	--------------------

China RoHS

Environment friendly use period (EFUP)	EFUP-E
	No hazardous substances above the limits

EU REACH SVHC

REACH candidate substance (CAS No.)	No substance above 0.1 wt%
-------------------------------------	----------------------------

Phoenix Contact 2026 © - all rights reserved
<https://www.phoenixcontact.com>

Phoenix Contact USA
586 Fulling Mill Road
Middletown, PA 17057, United States
(+717) 944-1300
info@phoenixcon.com