

VAL-MS 60 - Type 2 surge arrester

2868020

<https://www.phoenixcontact.com/us/products/2868020>

Please be informed that the data shown in this PDF document is generated from our online catalog. Please find the complete data in the user documentation. Our general terms of use for downloads are valid.



Surge arresters consisting of base element and protective connector with high-capacity varistor, for mounting on NS 35/7.5, 1-channel

Your advantages

- Quality proven millions of times over in the widest range of applications
- Rapid installation with bridges, thanks to industry-standard overall width of 1 HP
- Easy testing and insulation measurement, thanks to pluggable protection modules
- Wide range of applications due to various nominal voltages
- High degree of modularity provides individual solutions for every application

Commercial data

Item number	2868020
Packing unit	1 pc
Minimum order quantity	1 pc
Sales key	CL18
Product key	CL1321
GTIN	4017918930042
Weight per piece (including packing)	124.7 g
Weight per piece (excluding packing)	104.67 g
Customs tariff number	85363010
Country of origin	DE

VAL-MS 60 - Type 2 surge arrester

2868020

<https://www.phoenixcontact.com/us/products/2868020>

Technical data

Product properties

Product type	Surge arrester
Product family	VALVETRAB MS
IEC test classification	II
	T2
EN type	T2
IEC power supply system	TN
Type	DIN rail module, two-section, divisible
Number of positions	1
Surge protection fault message	optical
Number of ports	One

Insulation characteristics

Overvoltage category	III
Pollution degree	2

Electrical properties

Nominal frequency f_N	50 Hz (60 Hz)
-------------------------	---------------

Connection data

Connection method	Screw connection
Screw thread	M5
Tightening torque	3 Nm (1.5 mm ² ... 16 mm ²) 4.5 Nm (25 mm ² ... 35 mm ²)
Stripping length	16 mm
Conductor cross-section flexible	1.5 mm ² ... 25 mm ²
Conductor cross-section rigid	1.5 mm ² ... 35 mm ²
Conductor cross-section AWG	15 ... 2
Connection method	Fork-type cable lug
Conductor cross-section flexible	1.5 mm ² ... 16 mm ²

Dimensions

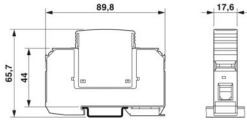
Dimensional drawing	
Width	17.6 mm
Height	89.8 mm
Depth	65.7 mm (incl. DIN rail 7.5 mm)
Horizontal pitch	1 Div.

VAL-MS 60 - Type 2 surge arrester



2868020

<https://www.phoenixcontact.com/us/products/2868020>

Material specifications

Color	black (RAL 9005)
Flammability rating according to UL 94	V-0
CTI value of material	600
Insulating material	PA 6.6/PBT
Material group	I
Housing material	PA 6.6 PBT

Protective circuit

Mode of protection	L-PEN
Direction of action	1L-N/PE
Nominal voltage U_N	60 V AC (TN) 60 V DC -48 V DC (RRH)
Nominal frequency f_N	50 Hz (60 Hz)
Maximum continuous operating voltage U_C	75 V AC 100 V DC
Rated load current I_L	80 A
Protective conductor current I_{PE}	≤ 0.45 mA
Standby power consumption P_C	≤ 35 mVA
Nominal discharge current I_n (8/20) μ s	15 kA
Maximum discharge current I_{max} (8/20) μ s	40 kA
Short-circuit current rating I_{SCCR}	25 kA
Voltage protection level U_p	≤ 0.55 kV
Residual voltage U_{res}	≤ 0.55 kV (at I_n) ≤ 0.425 kV (at 10 kA) ≤ 0.325 kV (at 5 kA) ≤ 0.275 kV (at 3 kA)
TOV behavior at U_T	100 V AC (5 s / withstand mode)
Response time t_A	≤ 25 ns
Max. backup fuse with V-type through wiring	80 A AC (gG)
Max. backup fuse with branch wiring	125 A AC (gG) 50 A DC (gG)

Environmental and real-life conditions

Ambient conditions

Degree of protection	IP20 (only when all terminal points are used)
Ambient temperature (operation)	-40 °C ... 80 °C
Ambient temperature (storage/transport)	-40 °C ... 80 °C
Altitude	≤ 2000 m (amsl)
Permissible humidity (operation)	5 % ... 95 %
Shock (operation)	25g (Half-sine / 11 ms / 3x \pm X, \pm Y, \pm Z)

VAL-MS 60 - Type 2 surge arrester



2868020

<https://www.phoenixcontact.com/us/products/2868020>

Vibration (operation)	5g (10 ... 500 Hz / 2.5 h / X, Y, Z)
-----------------------	--------------------------------------

Approvals

UL specifications

Maximum continuous operating voltage MCOV (L-N)	75 V AC
Maximum continuous operating voltage MCOV (L+) - (L-)	100 V DC
Nominal discharge current I_n (L-N)	10 kA
Nominal discharge current I_n (L+) - (L-)	10 kA
Mode of protection	L-N (L+) - (L-)
Nominal voltage	60 V AC
Nominal voltage	60 V DC
Power distribution system	Single phase
Nominal frequency	50/60 Hz
Measured limiting voltage MLV (L-N)	630 V
Measured limiting voltage MLV (L+) - (L-)	810 V
SPD Type	4CA

UL connection data

Tightening torque	30 lb _f -in.
Conductor cross-section AWG	14 ... 2

Standards and regulations

Standards/specifications	IEC 61643-11
Note	2011
Standards/specifications	EN 61643-11
Note	2012

Mounting

Mounting type	DIN rail: 35 mm
---------------	-----------------

VAL-MS 60 - Type 2 surge arrester

2868020

<https://www.phoenixcontact.com/us/products/2868020>



Drawings

Dimensional drawing

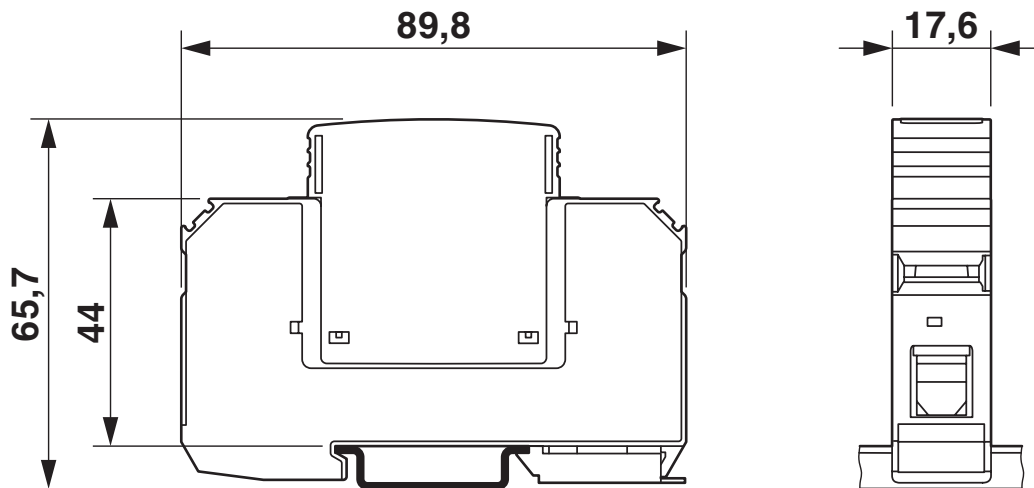

Circuit diagram

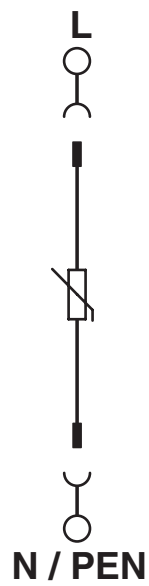

VAL-MS 60 - Type 2 surge arrester



2868020

<https://www.phoenixcontact.com/us/products/2868020>

Approvals

To download certificates, visit the product detail page: <https://www.phoenixcontact.com/us/products/2868020>



cUL Recognized

Approval ID: FILE E 330181



UL Recognized

Approval ID: FILE E 330181



IECEE CB Scheme

Approval ID: AT 2905/M1

CCA

Approval ID: NTR-AT 1947-A



KEMA-KEUR

Approval ID: 71-148002



CSA

Approval ID: 13631



ÖVE

Approval ID: 18583-001-17

UAE-RoHS

Approval ID: 22-09-51251



ÖVE

Approval ID: 18583-001-18

VAL-MS 60 - Type 2 surge arrester



2868020

<https://www.phoenixcontact.com/us/products/2868020>

Classifications

ECLASS

ECLASS-13.0	27171202
ECLASS-15.0	27171202

ETIM

ETIM 10.0	EC000941
-----------	----------

UNSPSC

UNSPSC 21.0	39121600
-------------	----------

VAL-MS 60 - Type 2 surge arrester



2868020

<https://www.phoenixcontact.com/us/products/2868020>

Environmental product compliance

EU RoHS

Fulfills EU RoHS substance requirements	Yes, No exemptions
-----------------------------------------	--------------------

China RoHS

Environment friendly use period (EFUP)	EFUP-E
	No hazardous substances above the limits

EU REACH SVHC

REACH candidate substance (CAS No.)	No substance above 0.1 wt%
-------------------------------------	----------------------------

Phoenix Contact 2026 © - all rights reserved
<https://www.phoenixcontact.com>

Phoenix Contact USA
586 Fulling Mill Road
Middletown, PA 17057, United States
(+717) 944-1300
info@phoenixcon.com